

NOIDA METRO RAIL CORPORATION (NMRC) LIMITED

REQUEST FOR PROPOSAL (RFP)

E-tender No. NMRC/DCOS/HDR/133R1/2021

Supply and installation of heavy-duty racks at various custody stores and DCOS building (Main Stores) at depot of N-GN corridor.

November 2021

Issued by:

**Noida Metro Rail Corporation (NMRC) Limited
Block-III, 3rd Floor,
Ganga Shopping Complex, Sector-29, Noida -201301,
District Gautam Buddha Nagar, Uttar Pradesh, India**

Disclaimer

This Request for Proposal (RFP) Document (or “E-Tender” or “E-Bid”) for “Supply and installation of heavy duty racks at various custody stores and DCOS building(Main Stores) at depot of N-GN corridor.” contains brief information about the scope of work and selection process for the Bidder (“the Contractor” or “the Tenderer”). The purpose of the Document is to provide the Bidders with information to assist the formulation of their Bidding Documents.

While all efforts have been made to ensure the accuracy of information contained in this RFP Document, this Document does not purport to contain all the information required by the Bidders. The Bidders should conduct their own independent assessment, investigations and analysis and should check the reliability, accuracy and completeness of the information at their end and obtain independent advice from relevant sources as required before submission of their Bid/s. Noida Metro Rail Corporation Ltd. (“NMRC” or “the Corporation”) or any of its employees or advisors shall incur no liability under any law, statute, rules or regulations as to the accuracy or completeness of the RFP Document.

NMRC reserves the right to change any or all conditions/information set in this RFP Document by way of revision, deletion, updating or annulment through issuance of appropriate addendum as NMRC may deem fit without assigning any reason thereof.

NMRC reserves the right to accept or reject any or all Bids without giving any reasons thereof. NMRC will not entertain or be liable for any claim for costs and expenses in relation to the preparation of the Bid/s to be submitted in terms of this RFP Document.

Glossary

- a) **“Addendum / Amendment”** means any written amendment / addendum /corrigendum to this RFP, from time to time issued by NMRC to the prospective bidders
- b) **“Agreement”** means the Contract Agreement to be executed between NMRC and the Selected Bidder
- c) **“Applicable Laws”** means all the laws including local, state, national or other laws, brought into force and effect by Govt. of India, State Governments, local bodies, statutory agencies and any other, and rules / regulations / notifications issued by them from time to time. It also includes judgments, decrees, injunctions, writs and orders of any court or judicial authority as may be in force and effected from time to time
- d) **“Bidder”** or **“Tenderer”** means any entity which is a sole proprietorship firm, a partnership firm or a company, in title and assigns which is submitting its bid pursuant to RFP Documents
- e) **“Bid Due Date”** means Bid Submission end date and time given in the E-tender
- f) **“e-Bid Security / Earnest Money Deposit (EMD)”** means the refundable amount to be submitted by the Bidder along with RFP documents to NMRC
- g) **“Performance Bank Guarantee/ Security Deposit”** means interest free amount to be deposited by the Contractor with NMRC as per terms and conditions of Contract Agreement as a security against the performance of the Contract agreement
- h) **“NMRC”** means Noida Metro Rail Corporation Limited (or “Corporation” or “Purchaser” or “Employer”)
- i) **“Party”** means Contractor or Corporation (together they are called **“Parties”**)
- j) **“Permits”** shall mean and include all applicable statutory, environmental or regulatory Contracts, authorization, permits, consents, approvals, registrations and franchises from concerned authorities
- k) **“Re. or Rs. or INR”** means Indian Rupee
- l) **“Revenue Operations Date (ROD)”** means the date of operation of Metro
- m) **“Selected Bidder”** means the bidder who has been selected by NMRC, pursuant to the bidding process for award of Contract
- n) **“Work”** means all the work specified or set forth and required in and by the said specifications, hereto annexed or to be implied there from or incidental thereto, or to be hereafter specified or required in such explanatory instructions and drawings (being in conformity with the said original specifications)

The words and expressions beginning with capital letters and defined in this document shall, unless repugnant to the context, have the meaning ascribed thereto hereinabove.

Data Sheet

1	Name of the Bid	RFP for Supply and installation of heavy duty racks at various custody stores and DCOS building (Main Stores) at depot of N-GN corridor.
2	Approximate Cost of Work	Rs. 1,92,55,690/- (Rupees One Crore Ninety Two Lakh Fifty Five thousand Six Hundred Ninety Only) (inclusive of all Taxes charges levies etc.)
3	Time-period of contract	90 Days for Supply and installation plus 24 Months warranty
4	Method of selection	Cost Based Selection (Lowest –L1)
5	Bid Processing Fee	Rs.5,900/- (Rupees Five Thousand Nine Hundred Only) (inclusive of GST) through RTGS/NEFT only payable in favor of Noida Metro Rail Corporation Limited
6	Earnest Money Deposit (EMD)	Rs. 3,86,000/- (Rupees Three Lakh Eighty Six Thousand only)
7	Bid System	Two Bid System (Technical and Financial)
8	Name of the Corporation and Official	GM (Technical) Noida Metro Rail Corporation, Block-III, 3rdFloor, Ganga Shopping Complex, Sector-29, Noida201301 Email: nmrcnoida@gmail.com Website:www.nmrcnoida.com, http://etender.up.nic.in
9	Bid Validity Period	180 days
10	Bid Language	English
11	Bid Currency	INR
12	Key Dates	Schedule
(a)	Uploading of Bid	November 26,2021
(b)	Date of pre-bid meeting	November 30,2021 [TIME 15:00 HRS]
(c)	Last date of receipt of Pre-bid Queries	December 01,2021 [TIME 17:00 HRS]
(d)	Last date of issuing amendment, if Any	December 06,2021
(e)	Last Date of Bid Submission	December 10,2021 [Time 15:30 HRS]
(f)	Date of Technical Bid Opening	December 10,2021 [Time 16:00 HRS]
13	Consortium to be allowed	No
14	Account details	For Bid Processing Fee & EMD State Bank of India (04077) – Sector 18, Noida Gautam Buddha Nagar, Uttar Pradesh - 201301 IFSC Code: SBIN0004077 A/c No. 37707840592 Noida Metro Rail Corporation Ltd.

Note: (i) Tender Cost and Tender Security is exempted for Micro & Small Enterprises (MSEs) registered with District Industries Centre or Khadi & Village Industries Commission or Khadi & Village Industries Board or Coir Board or National Small Industries Corporation or Dte. Of Handicraft & Handloom or any other bodies specified by Ministry of Micro, Small & Medium Enterprises for appropriate category and have valid registration certificate as on date of tender submission.

The MSEs would not be eligible for exemption of tender security if:

- a. Either they are not registered for appropriate category.
- b. Or they do not have valid registration as on the date of tender submission.

The tenderers seeking exemption from 'tender security', being MSEs, shall ensure their eligibility w.r.t above and submit registration certificate issued by the body under which they are registered which clearly mentions category of registration i.e. "Supply and Installation of Heavy duty racks" and Terminal Validity of registration.

In absence of any of the above requirements no exemption for 'tender security' will be allowed and tenderers eligibility shall be dealt as if they are not registered with MSMEs.

No further clarification shall be sought on the above.

1. In case the bidder who has been exempted Tender Cost/Tender Security being Micro & Small Enterprise and;

- (i) withdraws his Tender during the period of Tender validity or
- (ii) becomes the successful bidder, but fails to commence the work (for whatsoever reasons) as per terms & conditions of Tender; or
- (iii) refuses or neglects to execute the contractor
- (iv) fails to furnish the required Performance Security within the specified time,

The bidder shall be debarred from participating in future tenders for a period of 1 year from the date of discharge of tender/date of cancellation of NOA/annulment of award of contract as the case may be. Thereafter, on expiry of period of debarment, the bidder may be permitted to participate in the procurement process only on submission of required Tender Cost/ Tender Security.

Further the Employer may advise the authority responsible for issuing the exemption certificate to take suitable actions against the bidder such as cancellation of enlistment certificate etc.

Content

Glossary	2
Data Sheet	3
1. Section 1:General Information	6
1.1. Background.....	6
1.2. About Locations	6
1.3. Communication	6
2 Section 2: Terms of Reference	7
2.1. Scope of Work.....	7
3. Section 3: Instructions to Bidders.....	8
3.1 General instructions	8
3.2. Preparation and submission of Bids.....	10
3.3. Earnest Money Deposit	14
3.4. Opening and Evaluation of Bids.....	15
3.5. Award of Contract.....	16
4. Section 4: Qualification, Evaluation and Selection Process	17
4.1. Eligibility Criteria.....	17
4.2. Personnel.....	18
4.3. Compliance with Technical Specifications.....	19
4.4. Information of the Technical and Financial Proposal	19
4.5. Selection of Bidder	19
4.6. Notice of Award and Execution of Contract Agreement.....	20
4.7. Performance Bank Guarantee / Security Deposit	20
4.8. Contract during Proposal Evaluation.....	21
4.9. Other Instruction.....	21
5. Section 5: Special Conditions of Contract(SCC).....	22
6. Section 6: Technical Specification of Heavy Duty Racks (Please refer Annexure-6)	29
6.1 Sample Testing:	29
7. Section 7: Draft Contract Agreement	30
8. Section:8 Appendix to Form of Tender and Forms	33
8.1. Appendix 1: Metro Alignment.....	33
8.2. Form 1: Letter of Proposal Submission	34
8.3. Form 2:Firm Details.....	35
8.4. Form 3:Capability Statement	36
8.5. Form 4:Work Experience	38
8.6. Form 5: Financial Capability Details.....	40
8.7. Form 6:Memorandum	42
8.8. Form 7:Undertaking.....	43
8.9. Form 8: Power of Attorney	44
8.10. Form 9: Saleable Form for Tender Document	46
8.11. Form 10: Undertaking pertaining to Personnel	47
8.12. Form 11: Declaration of Refund of Earnest Money.....	48
8.13. Form 12: Bid Offer/BOQ (Format).....	49
8.14. Form 13: MAF (Manufacturer's Authorization Form).....	52
8.15. Form 14: Obligation/ Compliance to be ensured by Contractor.....	53
8.16. Form 15: Bid Details	54

ANNEXURES:

- Annexure 1: Drawing for OHE Store
- Annexure 2: Drawing for Electrical & Mechanical Store
- Annexure 3: Drawing for Heavy Maintenance Room
- Annexure 4: Drawing for PSI Store
- Annexure 5: Drawing for Ward 1 to 6 (DCOS Store)
- Annexure 6: Technical Specifications

1. Section 1: General Information

1.1. Background

- a. Noida and Greater Noida are being developed as the satellite towns to New Delhi and more and more people from Delhi and other areas are shifting to these towns in search of fresh air, greenery and better infrastructure. There is a need of providing an efficient, reliable and comfortable transportation system for the population intending to settle in these towns and also the public coming to these areas for education, service and business.
- b. Noida Metro Rail Corporation is a Special Purpose Vehicle (SPV) formed by Noida and Greater Noida Authorities for planning and executing urban transport projects in Noida, Greater Noida regions. The Corporation desires to provide a world-class Public Transportation System with state-of-the-art technology. As such, the overarching criterion for setting up of the Corporation is to help create an efficient, safe, reliable, economical and affordable public transport system.
- c. An elevated metro line between Noida and Greater Noida is already in operations in full swing.
- d. NMRC invites E-Bids for selection of Contractor for Supply and Installation of Heavy duty racks at various custody stores and DCOS building (Main Stores) at Depot of N-GN corridor
- e. In this regard, the Corporation now invites the interested Bidder/s to submit their proposals as per provisions of this RFP Document.
- f. NMRC will shortlist the Bidders on the basis of evaluation criteria mentioned in this RFP Document. On the basis of the minimum evaluation criteria, qualified Bidders will be shortlisted and financial proposal of only qualified Bidders will be opened.

1.2. About Locations

The metro corridor is 29.7 km long in first phase and is known as Noida Greater Noida Metro Rail Corridor. It comprises 21 metro stations starting from Noida Sector 51 in Noida and ends up at Depot Station in Greater Noida. The map is in Appendix 1: Metro Alignment.

1.3. Communication

All communications should be addressed to -

GM (Technical)

Noida Metro Rail Corporation (NMRC) Limited
Block-III, 3rd Floor, Ganga Shopping Complex, Sector-29,
Noida -201301
District Gautam Buddha Nagar, Uttar
Pradesh Email: nmrCNoida@gmail.com

2. Section 2: Terms of Reference

2.1. Scope of Work

- a. The work covered in the tender includes-

Supply and installation of heavy duty racks at various custody stores and DCOS building (Main Stores) of depot of N-GN corridor.

Time period:

- 90 Days for supply and installation.
- The warranty of the products shall be for a period of 2year from the date of issuance of acceptance/ work completion certificate.

- b. The details of the Requirement areas below:

Sr. No	Drawings	Type of Racks	STORES AREA/Type	Total Qty
1	Annexure-1	Boltless Single Tier with Partition	OHE STORE (Type A)	4
2	Annexure-1	Long span Single Tier Racks	OHE STORE (Type B)	7
3	Annexure-1	Cantilever Racking System	OHE STORE (Type C)	11
4	Annexure-2	Long span Single Tier Racks	ELECTRICAL & MECH (Type B)	15
5	Annexure-3	Boltless Single Tier Racks	HEAVY MAINT. ROOM (Type A)	6
6	Annexure-3	Long span Single Tier Racks	HEAVY MAINT. ROOM (Type B)	13
7	Annexure-4	Long span Single Tier Racks	PSI (Type B)	15
8	Annexure-5	Long span Multitier Tier Racks	WARD 1- A UNIT (MT)	25
9	Annexure-5	Long span Multitier Tier Racks	WARD 2- A UNIT(MT)	21
10	Annexure-5	Long span Multitier Tier Racks	WARD 3- A UNIT(MT)	21
11	Annexure-5	Long span Multitier Tier Racks	WARD 4- A UNIT(MT)	21
12	Annexure-5	Long span Multitier Tier Racks	WARD 5 - A UNIT(MT)	18
13	Annexure-5	Long span Multitier Tier Racks	WARD 6 - A UNIT(MT)	10
14	Annexure-5	Boltless Multitier Tier Racks	B UNIT (ALL WARDS)	12
15	Annexure-5	Heavy Duty Single Tier Racks	C UNITS (ALL WARDS)	21

Please refer annexure – 6 for Technical specifications

- c. Steel to be used must be of MS Grades IS10748, IS 513 and IS 5986.
- d. Bidders may also visit NMRC sites located at Depot of NMRC (Greater Noida) during office timings.
- e. Bidders are also required to submit comprehensive drawings and specification datasheets in line with technical specifications as per RFP with their bids.
- f. Racks are to be supplied and installed within 3 (Three) Months from the date of signing of contract. In case if delivery is delayed penalty will be imposed at the rate of 0.5 percent of the contract value per week to a limit of 2.5 percent. Contract will be terminated after 5 weeks of delay from last day of delivery period. In such an event, NMRC shall be titled to forfeit Bid Security or Security Deposit (interest free)/ Performance Bank Guarantee.
- g. NMRC may do inspections for quality check at any stage of tendering process.

Section 3: Instructions to Bidders

3.1 General instructions-

- a. A Bidder/OEM is eligible to submit only one Tender for the Project. A Bidder/OEM applying shall not be entitled to submit another Tender, as the case may be. Any Bidder/OEM, which submits or participates in more than one tender/proposal, would be disqualified.
- b. The Bidder/OEM shall initiate, and actively pursue and involve itself in all investigations and enquiries, Corporation feedbacks, information, convening of and attendance at meetings, and in any other activities as are or may be necessary for producing high quality work as per the requirements.
- c. The Bidder/OEM shall carry out the services in compliance with the provisions of this Agreement. Any and all changes necessary to ensure that the Bidder's documents conform to the intent and purpose set out in the Agreement, shall be made at the Bidder's own expense.
- d. Bidders/OEM shall be evaluated on the basis of the Evaluation Criteria specified in this document. Bidders/OEM shall be deemed to have understood and agreed that no explanation or justification for any aspect of the Selection Process will be given and that NMRC's decisions are without any right of appeal whatsoever.
- e. Any entity which has been barred by the Central/State Government in India or by any entity controlled by them, from participating in any project, and the bar subsists as on the date of Bid, would not be eligible to submit an e-Bid.
- f. A Bidder/OEM should have, during the last five years, neither failed to perform on any agreement, as evidenced by imposition of a penalty by an arbitral or judicial authority or a judicial pronouncement or arbitration award against the Bidder, nor been expelled from any project or agreement nor have had any agreement terminated for breach by such Bidder.
- g. Bidders/OEM are encouraged to inform themselves fully about the assignment and the local conditions before submitting the e-Bid by paying a visit to the Corporation and/or by sending written queries to NMRC before the last date for receiving queries/clarifications.
- h. NMRC shall not be liable for any omission, mistake or error on the part of the Bidder in respect of any of the above or on account of any matter or thing arising out of or concerning or relating to e-Bid or the Selection Process, including any error or mistake therein or in any information or data given by NMRC.
- i. Any new taxes or any statutory variation [which comes into effect after the last date of submission of Bid on any item] during the contractual completion shall be to the Employer's account for which the Bidder shall furnish the documentary evidence in support of their claims. However, any increase in cost due to new taxes or change in existing taxes introduced during extended contractual period due to Bidder's fault shall be to his account.
- j. The currency for the purpose of the Proposal shall be the Indian Rupee (INR).

3.1.1 Cost of Bid Document / e-Tender processing Fee

- a. The tenderer shall bear all costs associated with the preparation and submission of its e-Bid and Noida Metro Rail Corporation Ltd. ("NMRC" or "the Corporation"), will in no case be responsible or liable for these costs, regardless of the conduct or outcome of the e-Bid process.
- b. This tender document is available on the web site <http://etender.up.nic.in> or on NMRC website (www.nmrcnoida.com) to enable the tenderers to view, download the e-Bid document and submit e-Bids online up to the last date and time mentioned in e-Tender notice/e-tender document against this e-Tender. The tenderers shall have to pay cost of bid document/e-

RFP for supply and installation of heavy-duty racks at various custody stores and DCOS building (Main Stores) at Depot of N-GN corridor.

Tender processing fee of as mentioned in **Data Sheet** through RTGS/NEFT only payable in favor of Noida Metro Rail Corporation Limited in the A/c No. mentioned in **Data Sheet**. The scanned copy of RTGS/NEFT receipt with transaction Id certified by the same bank must be enclosed along with the e-Bid. This cost of bid document/ e-Tender processing fee as mentioned in **Data Sheet** will be non-refundable. Tender without cost of bid document/ e-Tender processing fee in the prescribed form, will not be accepted.

3.1.2 Acknowledgement by Bidder

It shall be deemed that by submitting the e-Bid, the Bidder has:

- a. made a complete and careful examination of the e-Bid;
- b. received all relevant information requested from NMRC;
- c. acknowledged and accepted the risk of inadequacy, error or mistake in the information provided in the e-Bid or furnished by or on behalf of NMRC;
- d. satisfied itself about all matters, things and information, necessary and required for submitting an informed Application and performance of all of its obligations there under;
- e. acknowledged that it does not have a Conflict of Interest and
- f. agreed to be bound by the undertaking provided by it under and in terms hereof.

3.1.3 Availability of Bid Document

This Bid document is available on the web site <http://etender.up.nic.in> and on Noida Metro website www.nmrcnoida.com to enable the Bidders to view, download the e-Bid document and submit e-Bids online up to the last date and time mentioned in e-Bidder notice/ e-Bid document. The Bidder's shall have to pay e-Bid document fee and EMD as mentioned in Data sheet through RTGS/NEFT on addresses given in data sheet. The scanned copy of RTGS/NEFT with transaction ID certified by the same bank must be enclosed along with the e-Bid. This e-Bid document fee will be non-refundable. Bid without Bid fee in the prescribe form will not be accepted.

3.1.4 Clarifications of e-Bid

- a. During evaluation of e-Bid, NMRC may, at its discretion, ask the Bidder for a clarification of his/her e-Bid. The request for clarification shall be in writing.
- b. Any queries or request for additional information concerning this RFP shall be submitted in writing or by fax and e-mail to the **GM (Technical)**, NMRC only within seven days of issuance of tender. The envelopes/ communication shall clearly bear the following identification/ title: "**Queries/ Request for Additional Information**: "Supply and installation of heavy duty racks at various custody stores and DCOS building (Main Stores) of depot of N-GN corridor". The responses will be posted to all such queries on the official Website www.nmrcnoida.com. NMRC reserves the right not to respond to any questions or provide any clarifications, in its sole discretion, and nothing in this Clause shall be taken or read as compelling or requiring NMRC to respond to any question or to provide any clarification.
- c. In case the Bidder seeks for any queries, he shall send letter or e-mail to the correspondence address given in Data Sheet.
- d. However, NMRC shall not entertain any correspondence from the Bidders during the period of e-Bid opening to selection of the successful Bidder. Any wrong practice shall be dealt in accordance with the Section of this e-Bid document under Fraud and Corrupt Practices.

3.1.5 Amendment of e-Bid Document

- a. At any time prior to the deadline for submission of e-Bid, NMRC may, for any reason, whether at it's on in iterative or in response to a clarification requested by a prospective Bidder, modify the e-Bid document by amendments. Such amendments shall be uploaded on the-

RFP for supply and installation of heavy-duty racks at various custody stores and DCOS building (Main Stores) at Depot of N-GN corridor.

procurement website <http://etender.up.nic.in>. The relevant clauses of the e-Bid document shall be treated as amended accordingly.

- b. It shall be the sole responsibility of the prospective Bidder to check the web site <http://etender.up.nic.in> or NMRC's website www.nmrcnoida.com from time to time for any amendment in the e-Bid documents. In case of failure to get the amendments, if any, NMRC shall not be responsible for it.
- c. In order to allow prospective e-Bids a reasonable time to take the amendment into account in preparing their e-Bids, NMRC, at the discretion, may extend the deadline for the submission of e-Bids. Such extensions shall be uploaded on the e-procurement website <http://etender.up.nic.in> or NMRC's website www.nmrcnoida.com.

3.2. Preparation and submission of Bids

3.2.1. Language of e-Bid

The e-Bid prepared by the Bidder, as well as all correspondence and documents relating to the e-Bid exchanged by the Bidder and NMRC shall be written in English language. Only English numerals shall be used in the e-Bid. The correspondence and documents in any other language must be accompanied by transcripts verified by the Embassy of Home Country or equivalent.

3.2.2. Documents constituting the e-Bid

The e-Bid prepared by the Bidder shall comprise the following components:

a. Technical e-Bid- Technical e-Bid will comprise of-

- i. **Fee details** - Details of Bid processing fee and prescribed EMD
- ii. **Eligibility details**- Includes copies of required documents of Bidder/OEM in PDF format justifying that the Bidder is qualified to perform the contract if his/her bid is accepted and the Bidder has financial & technical capability necessary to perform the contract and meets the criteria outlined in the Qualification requirement and technical specification and fulfill all the conditions of the contract.
- iii. **Technical evaluation** - Details of all documents needed for Technical evaluation as mentioned in this RFP

b. Financial e-Bid -

- i. **Price bid** –Bill of Quantities in XLS format to be filled in after downloading from the e-Procurement website for this e-tender. There shall be a single financial quote.

3.2.3. Documents establishing Bidder's Qualification

- a. The OEM/Bidder shall furnish, as part of its technical e-Bid, documents establishing the Bidder's qualification to perform the contract if its e-Bid is accepted. The documentary evidence should be submitted by the OEM/Bidder electronically in the PDF format.
- b. The documentary evidence of OEM/Bidder's qualification to perform the contract if its e-Bid is accepted shall be as per qualification requirements specified in e-Bid document.

3.2.4. E-Bid form

The Bidder shall complete the e-Bid form and the appropriate price schedule/BOQ furnished in the e-Bid document. Financial Quote shall comprise of the rate of Total Price for RFP for Supply and Installation of Heavy duty racks at various custody stores and DCOS building (Main Stores) at Depot of N-GN corridor in the Bid form in figures.

3.2.5. E-Bid Currency

Prices shall be quoted in Indian Rupees only.

3.2.6. Formats and Signing of e-Bid

- a. The Bidder shall prepare one electronic copy of the technical e-Bid and financial e-Bid separately.
- b. The e-Bid document shall be digitally signed, at the time of uploading, by the Bidder or a person or persons duly authorized to bind the Bidder to the contract. The later authorization shall be indicated by a scanned copy of written power-of attorney accompanying the e-Bid. All the pages/documents of the e-Bid that are to be uploaded shall be digitally signed by the person authorized to sign thee-Bid.
- c. Bidders should provide all the information as per the RFP and in the specified formats. NMRC reserves the rights to reject any proposal that is not in the specified formats.
- d. In case the Bidders intends to provide additional information for which specified space in the given format is not sufficient, it can be furnished in duly stamped and signed PDFs.

3.2.7. Deadline for submission of e-Bid

E-Bid (Technical and financial) must be submitted by the Bidder at e-procurement website <http://etender.up.nic.in> not later than the time specified on the prescribed date (as the server time displayed in the e-procurement website). NMRC may, at its discretion, extend this deadline for submission of e-Bid by amending the e-Bid document, in which case all rights and obligations of NMRC and Bidders previously subject to the deadline will thereafter be subject to the deadline as extended.

3.2.8. Submission of e-Bid

- a. The bid submission module of e-procurement website <http://etender.up.nic.in> enables the Bidders to submit the e-Bid online in response to this e-Bid published by NMRC.
- b. Bid submission can be done only from the bid submission start date and time till the bid submission end date and time given in the e-Bid. Bidders should start the bid submission process well in advance so that they can submit their e-Bid in time.
- c. The Bidder should submit their e-Bid considering the server time displayed in the e-procurement website. This server time is the time by which the e-Bid submission activity will be allowed till the permissible time on the last/end date of submission indicated in the e-Bid schedule.
- d. Once the e-Bid submission date and time is over, the Bidders cannot submit their e-Bid. For delay in submission of e-Bid due to any reasons, the Bidders shall only be held responsible.

The Bidders have to follow the following instructions for submission of their e-Bid:

- a. For participating in e-Bid through the e-Bidding system it is necessary for the Bidders to be the registered users of the e-procurement website <http://etender.up.nic.in>. The Bidders must obtain a user login Id and password by registering themselves with U.P. Electronics Corporation Ltd., Lucknow if they have not done so previously for registration.
- b. In addition to the normal registration, the Bidder has to register with his/her digital signature certificate (DSC) in the e-Bidding system and subsequently he/she will be allowed to carry out his/her e-Bid submission activities. Registering the digital signature certificate (DSC) is a one-time activity. Before proceeding to register his/her DSC, the Bidder should first log on to the e-Bidding system using the user login option on the home page with the login Id and password with which he/she has registered.

For successful registration of DSC on e-procurement website <http://etender.up.nic.in> the Bidder must ensure that he/she should possess class-2/class-3 DSC issued by any certifying authorities approved by controller of certifying authorities, Government of India, as the e-procurement website <http://etender.up.nic.in> is presently accepting DSC issued

by these authorities only. The Bidder can obtain user login Id and perform DSC registration exercise given above even before the e-Bid submission date starts. NMRC shall not be held responsible if the Bidder tries to submit his/her e-Bid at the moment before end date of submission but could not submit due to DSC registration problem.

- c. The Bidder can search for active Bids through "search active tenders" link, select a Bid in which he/she is interested in and then move it to 'My Tenders' folder using the options available in the e-Bid submission menu. After selecting and the Bid, for which the Bidder intends to e-Bid, from "My tenders" folder, the Bidder can place his/her e-Bid by clicking "pay offline" option available at the end of the view Bid details form. Before this, the Bidder should download the e-Bid document and price schedule/bill of quantity (BOQ) and study them carefully. The Bidder should keep all the documents ready as per the requirements of e-Bid document in the PDF format except the price schedule /bill of quantity (BOQ) which should be in the XLS format (excel sheet).
- d. After clicking the 'pay offline' option, the Bidder will be redirected to terms and conditions page. The Bidder should read the terms & conditions before proceeding to fill in the Bid fee and EMD offline payment details. After entering and saving the Bid fee and EMD details form so that "bid document preparation and submission" window appears to upload the documents as per technical (fee details, qualification details, e-Bid form and technical specification details) and financial (e-Bid form and price schedule/BOQ) schedules/packets given in the Bid details. The details of the RTGS/NEFT should tally with the details available in the scanned copy and the date entered during e-Bid submission time otherwise the e-Bid submitted will not be accepted.
- e. Next the Bidder should upload the technical e-Bid documents for fee details (e-Bid fee and EMD), Qualification details. Before uploading, the Bidder has to select the relevant digital signature certificate. He may be prompted to enter the digital signature certificate password, if necessary. For uploading, the Bidder should click "browse" button against each document label in technical and financial schedules/packets and then upload the relevant PDF/XLS files already prepared and stored in the Bidder's computer. The required documents for each document label of technical (fee details, qualification details, e-Bid form and technical specification details) and financial (e-Bid form and price schedule/BOQ) schedules/packets can be clubbed together to make single different files for each label.
- f. The Bidder should click "Encrypt" next for successfully encrypting and uploading of required documents. during the above process, the e-Bid document are digitally signed using the DSC of the Bidder and then the documents are encrypted/locked electronically with the DSC's of the bid openers to ensure that the e-Bid documents are protected, stored and opened by concerned bid openers only.
- g. After successful submission of e-Bid document, a page giving the summary of e-Bid submission will be displayed confirming end of e-Bid submission process. The Bidder can take a printout of the bid summary using the "print" option available in the window as an acknowledgement for future reference.
- h. NMRC reserves the right to cancel any or all e-Bids without assigning any reason.

3.2.9. Late e-Bid

- a. Bids received by NMRC after the specified time on the Bid Due Date shall not be eligible for consideration and shall be summarily rejected.
- b. The server time indicated in the bid management window on the e- procurement website <http://etender.up.nic.in> will be the time by which the e-Bid submission activity will be allowed till the permissible date and time scheduled in thee-Bid.

- c. Once the e-Bid submission date and time is over, the Bidder cannot submit his/her e-Bid. Bidder has to start the bid submission well in advance so that the submission process passes off smoothly. The Bidder will only be held responsible if his/her e-Bid is not submitted in time due to any of his/her problems/faults, for whatsoever reason, during e-Bid submission process.

3.2.10. Withdrawal and resubmission of e-Bid

- a. At any point of time, a Bidder can withdraw his/her e-Bid submitted online before the bid submission end date and time. For withdrawing the Bidder should first log in using his/her login id and password and subsequently by his/her digital signature certificate on the e-procurement website <http://etender.up.nic.in>. The Bidder should then select "My bids" option in the bid submission menu. The page listing all the bids submitted by the Bidder will be displayed. Click "View" to see the details of the bid to be withdrawn. After selecting the "bid withdrawal" option the Bidder has to click "Yes" to the message "Do you want to withdraw this bid?" displayed in the bid information window for the selected bid. The Bidder also has to enter the bid withdrawing reasons and upload the letter giving the reasons for withdrawing before clicking the "Submit" button. The Bidder has to confirm again by pressing "OK" button before finally withdrawing his/her selected e-Bid.
- b. No e-Bid may be withdrawn in the interval between the deadline for submission of e-Bids and the expiration of period of e- bid validity. Withdrawal of an e-Bid during this interval may result in the forfeiting of Bidder's e-Bid security.
- c. The Bidder can re-submit his/her e-Bid as when required till the e-Bid submission end date and time. The e-Bid submitted earlier will be replaced by the new one. The payment made by the Bidder earlier will be used for revised e-Bid and the new e-Bid submission summary generated after the successful submission of the revised e-Bid will considered for evaluation purposes. For resubmission, the Bidder should first log in using his/her login Id and password and subsequently by his/her digital signature certificate on the e-procurement website <http://etender.up.nic.in>. The Bidder should then select "My bids" option in the bid submission menu. The page listing all the bids submitted by the Bidder will be displayed. Click "View" to see the detail of the e-Bid to be resubmitted. After selecting the "bid resubmission" option, click "Encrypt & upload" to upload the revised e-Bids documents.
- d. The Bidder can submit their revised e-Bids as many times as possible by uploading their e-Bid documents within the scheduled date & time for submission of e-Bids.
- e. No e-Bid can be resubmitted subsequently after the deadline for submission of e-Bids.

3.2.11. NMRC's right to accept any e-Bid and to reject any or all e-Bids.

- a. Notwithstanding anything contained in this e-Bid, NMRC reserves the right to accept or reject any Bid and to annul the Selection Process and reject all Bids, at any time without any liability or any obligation for such acceptance, rejection or annulment, and without assigning any reasons thereof.
- b. NMRC reserves the right to reject any Bid if:
 - At any time, a material misrepresentation is made or uncovered, or
 - The Bidder does not provide, within the time specified by NMRC, the supplemental information sought by NMRC for evaluation of thee-Bid.
- c. Such misrepresentation/ improper response may lead to the disqualification of the Bidder. If such disqualification /rejection occurs after the e-Bid have been opened and the highest ranking Bidder gets disqualified / rejected, then the NMRC reserves the right to consider the next best Bidder, or take any other measure as may be deemed fit in the sole discretion of NMRC, including annulment of the Selection Process.

RFP for supply and installation of heavy-duty racks at various custody stores and DCOS building (Main Stores) at Depot of N-GN corridor.

3.2.12. Period of validity of e-Bid

- a. E-Bid shall remain valid for 180 days after the date of e-Bid opening prescribed by NMRC. An e-Bid valid for a shorter period shall be rejected by NMRC as non-responsive.
- b. In exceptional circumstances, NMRC may solicit the Bidder's consent to an extension of the period of e-Bid validity. The request and the response thereto shall be made in writing.

3.2.13. Correspondence with the Bidder

- a. Save and except as provided in this e-Bid, NMRC shall not entertain any correspondence with any Bidder or its Technical Partners in relation to acceptance or rejection of any e-Bid.
- b. Subject to Clause 3.4.5 no Bidders or its Technical Partners shall contact NMRC on any matter relating to his e-Bid from the time of Bid opening to the time contract is awarded.
- c. Any effort by the Bidder or by its Technical Partners to influence NMRC in the Bid evaluation, Bid comparison or contract award decisions, may result in the rejection of his Bid.

3.3. Earnest Money Deposit

3.3.1. Earnest money deposit (EMD)

- a. The tenderer shall furnish, as part of its e-Bid, an e-Bid security/ EMD as stated in Data Sheet (Rs. 3,86,000) in form of RTGS/NEFT only in favour Noida Metro Rail Corporation Limited in the A/c No. mentioned in **Data Sheet**. The scanned copy of RTGS/NEFT receipt of Security/ EMD with transaction Id certified by the same bank must be enclosed along with the e-Bid. Tender without Earnest Money in the prescribed form, will not be accepted.
- b. Any e-Bid not secured in accordance with above shall be treated as non-responsive and rejected by NMRC.
- c. Unsuccessful Bidder's EMD will be returned promptly as possible after opening of the Price Bid.
- d. No interest will be paid by the Purchaser on the Earnest Money Deposit.
- e. The successful Bidder's e-Bid EMD will be adjusted with Performance Bank Guarantee, if applicable, to be submitted by the Bidder upon signing the contract.
- f. The EMD may be forfeited:
 - i. If Bidder (a) withdraws its e-Bid during the period of e-Bid validity specified by the Bidder on the e- bid form: or (b) does not accept the correction of errors or (c) modifies its e-Bid price during the period of e-Bid validity specified by the Bidder on the form.
 - ii. In case of a successful Bidder, if the Bidder fails to sign the contract with the Corporation.
- g. Tender Cost and Tender Security is exempted for Micro & Small Enterprises (MSEs) registered with District Industries Centre or Khadi & Village Industries Commission or Khadi & Village Industries Board or Coir Board or National Small Industries Corporation or Dte. Of Handicraft & Handloom or any other bodies specified by Ministry of Micro, Small & Medium Enterprises for appropriate category and have valid registration certificate as on date of tender submission.

The MSEs would not be eligible for exemption of tender security if:

- a. Either they are not registered for appropriate category.
- b. Or they do not have valid registration as on the date of tender submission.

The tenderers seeking exemption from 'tender security', being MSEs, shall ensure their eligibility w.r.t above and submit registration certificate issued by the body under which they are registered which clearly mentions category of registration i.e. "Supply and Installation of Heavy duty racks" and Terminal Validity of registration.

3.4. Opening and Evaluation of Bids

3.4.1. Opening of technical e-Bid by NMRC

- a. NMRC will open all technical e-Bids, in the presence of Bidder's representatives who choose to attend on the prescribed date of opening at NMRC Office. The Bidder's representatives who are present shall sign a register evidencing their attendance. In the event of the specified date e-Bid opening being declared a holiday for the Corporation, the e –bids shall be opened at the appointed time and place on the next working day.
- b. The Bidder who is participating in e-Bid should ensure that the RTGS/NEFT of Bid Processing Fee and EMD must be submitted in the prescribed account of NMRC within the duration (strictly within opening & closing date and time of individual e-Bid) of the work as mentioned in Bid notice, otherwise, in any case, e-Bid shall be rejected.
- c. The Bidders names and the presence or absence of requisite e-Bid security and such other details as NMRC at its discretion may consider appropriate, will be announced at the opening.

3.4.2. Opening of financial e-Bid

- a. After evaluation of technical e-Bid, through the evaluation committee NMRC shall notify those Bidders whose technical e-Bids were considered non-responsive to the conditions of the contract and not meeting the technical specifications and qualification requirements indicating that their financial e-Bids will not be opened.
- b. NMRC will simultaneously notify the Bidders, whose technical e-Bids were considered acceptable to the Corporation. The notification may sent by e-mail provided by-bidder.
- c. The financial e-Bids of technically qualified Bidders shall be opened in the presence of technically qualified bidders who choose to attend. The date and time for opening of financial bids will be communicated to the technically qualified Bidders subsequently after completion of technical bids evaluation through e-mail provided by the Bidder. The name of Bidders, percentage price quoted for various items etc. will be announced at the meeting.

3.4.3. Correction of Errors

- a. Financial Bids determined to be responsive will be checked by NMRC for any arithmetic errors. Where there is a discrepancy between the rate quoted in the Financial Bid, in figures and in words, the amount in words will prevail over the amounts in figures, to the extent of such discrepancy.
- b. The amount stated in the Financial Bid will be adjusted by NMRC in accordance with the above procedure for the correction of errors and shall be considered as binding upon the Bidder. If the Bidder does not accept the corrected quoted rate of e-Bid, his e-Bid will be rejected, and his Bid Security shall be liable for forfeiture in accordance with Clause 3.3.1f

3.4.4. Examination of e-Bid document

- a. The NMRC will examine the e-Bid to determine if:
 - i. They are complete;
 - ii. They meet all the conditions of the contract;
 - iii. The required e-Bid Processing fee, EMD and other required documents have been furnished;
 - iv. The documents have been properly digitally signed; and
 - v. The e-Bids are in order.
- b. Any e-Bid or e-Bids not fulfilling these requirements shall be rejected.

3.4.5. Contacting NMRC

- a. No Bidder shall contact NMRC on any matter relating to his/her e-Bid, from the time of the e-Bid opening to the time the contract is awarded. If the Bidder wishes to bring additional information to the notice of NMRC, he/she can do so in writing.
- b. Any effort by a Bidder to influence NMRC in its decisions on e-Bid evaluation, e- bid comparison or contract award may result in rejection of the Bidder's e-Bid.
- c. In the event of any information furnished by the Bidder is found false or fabricated, the minimum punishment shall be debarring /blacklisting from Noida Metro works and legal proceeding can also be initiated. EMD of such bidders will be forfeited.

3.4.6. Confidentiality

- a. Information relating to the examination, clarification, evaluation, and recommendation for the Bidders shall not be disclosed to any person who is not officially concerned with the process or is not a retained professional advisor advising NMRC in relation to or matters arising out of, or concerning the Bidding Process. Any effort by a Bidder to exert undue or unfair influence in the process of examination, clarification, evaluation and comparison of Proposal shall result in outright rejection of the offer, made by the said Bidder.
- b. NMRC shall treat all information, submitted as part of Bid, in confidence and shall require all those who have access to such material to treat the same in confidence. NMRC may not divulge any such information unless it is directed to do so by any statutory entity that has the power under law to require its disclosure or is to enforce or assert any right or privilege of the statutory entity and/ or NMRC or as may be required by law or in connection with any legal process.

3.5. Award of Contract

3.5.1. Award Criteria

- a. NMRC will award the contract as per evaluation criteria stated in the RFP Document.
- b. NMRC will award the contract to the successful Bidder whose bid has been determined to be responsive to all the conditions of the contract and meeting the eligibility requirement of the bidding document.

3.5.2. Notice of Award (NOA)

- a. Prior to the expiration of the period of e-Bid validity, NMRC will notify the successful Bidder in writing, by letter/e-mail/fax, that its e-Bid has been accepted.
- b. The acceptance of NOA will constitute the formation of the contract.

3.5.3. Contract

- a. This contract is for the supply, install, commissioning, training and maintenance of the equipment of the description, specifications and drawings, and in the quantities set forth in the contract on the date or dates specified therein. All equipment must be brand new and unused. Unpacking/seal opening has to be done in presence of NMRC.
- b. The whole contract is to be executed in the most approved, substantial and workmanship manner, to the entire satisfaction of the Purchaser or his nominee, who, both personally and may his deputies, shall have full power, at every stage of progress, to inspect the equipment at such times as he may deem fit and to reject any of the equipment which he may disapprove.

3.5.4. Signing of contract

At the same time as NMRC notifies the successful Bidder that it's e-Bid has been accepted, the successful Bidder shall have to sign the contract agreement with relevant document as mentioned in the RFP. The agreement draft along with other related terms and conditions will be same as furnished in this e-Bid. Any refusal will not be allowed. The Bidder need not download and submit in hard copies of these

documents.

3.5.5. NMRC's right to accept any e-Bid and to reject any or all e-Bids

NMRC reserves the right to accept or reject any e-Bid, and to annul the e-Bid process and reject all e-Bids at any time prior to contract award, without thereby incurring any liability to the affected tenderer or tenderers.

Section 4: Qualification, Evaluation and Selection Process

4.1. Eligibility Criteria

The Bidder's competence and capability is proposed to be established by the following parameters. The Bidder should meet all the criteria given in this section.

- a. The Bidder should be Sole proprietorship/registered partnership firm/ public limited company/ private limited company. The firm and the companies should be registered in India. The firm and the companies must be BIFMA Level 3 certified, ISO 2001, ISO 45001 and EN 15512 certified. The firm must have a regional office in Dehi-NCR region.
- b. The Bidder/OEM should have successfully completed in India during last **7 (Seven) years** period ending last day of month previous to the one:
 - i. One order of similar nature of value not less than **Rs. 1,54,05,000/-**(Rupees One crore fifty four lakh five thousand only) or
 - ii. Two orders of similar nature of value not less than **Rs. 96,28,000/-**(Rupees Ninety six lakh twenty eight thousand only) each or
 - iii. Three orders of similar nature of value not less than **Rs. 77,03,000/-**(Rupees Seventy seven lakh three Thousand only)each

Definition of Similar Works –Experience in Supply and Installation of Heavy duty racks /Storage in Stores/warehousing facilities at Railways/Metros/Airports/Bus Depots/Office Premises/Shopping Malls/ Hospitals/ Hotels/Institutes/Reputed Private Firms utilizing similar work. Bidder can submit the credential of OEM along with MAF (Manufacturer Authorization letter as per annexure 7) for participation in this particular tender.

- c. The Bidder/OEM should have minimum **average annual turnover** of **Rs. 1.54 Crore/-**(Rupees One crore Fifty-Four Lakh Only) in the last 3 (three) Financial Years (**2018-2019, 2019-20, 2020-21**) preceding the Bid Due Date.
- d. Bidder should have minimum net worth of **Rs 38.51 Lakh/-**(Rupees Thirty Eight Lakh Fifty One Thousand only) in last audited financial year.
- e. It is necessary that the firm can withstand cash flow that the contract will require until payment received from the employer. Liquidity therefore becomes an important consideration. This shall be seen from the balance sheet. Net current assets from balance sheet of last year audited **Rs 27.51 Lakhs** (Rupees Twenty-Seven Lakh Fifty-One Thousand Only) cash flow for this contract.
- f. The Bidder/OEM should not have been blacklisted/ banned/ declared ineligible for corrupt and fraudulent practices by the Government of India/ any State Government/ Government Agency and Supreme court and contracts have been terminated/ foreclosed by any company / department due to non- fulfillment of Contractual obligation in last 5 (five) financial years.
- g. The Bidder should have positive profit before tax in 2(two)out of the last 5 (five) Financial Years (**2016-17,2017-2018, 2018-19, 2019-20,2020-21**) preceding Bid Due Date.
- h. The Bidder should submit the notarized affidavit that the bidder has not been blacklisted by any

RFP for supply and installation of heavy-duty racks at various custody stores and DCOS building (Main Stores) at Depot of N-GN corridor.

state/ central government/ organization in last 5 (five) financial years.

NMRC, if required, may seek clarifications from bidders during the technical evaluation.

The Bidder shall also furnish the following:

- a. For above criteria 4.1a
 - i. Statutory proof of existence as the legal entity
 - ii. Power of attorney as in Form 9: Power of Attorney
 - iii. Memorandum and Articles of Association showing the objectives of the company/ firm (as per applicability)
- b. For above criteria 4.1b
 - i. A statement as in Form 4: Work Experience of OEM/Bidder with documentary proof
- c. For above criteria 4.1c, 4.1d, 4.1e & 4.1g
 - i. Form 5: Financial Capability Details
 - ii. A copy of the Annual Reports (Profit and Loss Account and Balance Sheet) for the last 5 (five) Financial Years of Bidder
A copy of the Audited balance sheets and Profit and Loss Statements for the last 5 (five) financial years.
In case the Financial Statements for the latest financial year are not audited and therefore the Bidder cannot make it available, the Bidder shall give an undertaking to this effect and the statutory auditor/charted accountant shall certify the same. In such a case, the Bidder shall provide the Audited Financial Statements for 2 (two) years preceding the year for which the Audited Financial Statement is not being provided. Also, pertaining to latest financial year, the bidder shall submit an affidavit certifying that “The Annual Accounts have not been audited so far. We are submitting the CA certified provisional accounts, which shall be substantiated by the Audited Accounts, when prepared.”
 - iii. A self-attested copy of valid ITR for last three financial years.
 - iv. A self-attested copy of PAN, GST registration
- d. For above criteria 4.1f
 - i. Form 8: Undertaking

4.2. Personnel

The Tenderer shall submit – Form 11: Undertaking pertaining to Personnel staffing schedule containing the names, qualifications, professional experience and corporate affiliation of all proposed management personnel (above the level of shift supervisor) and specialists for this work. The submission shall include a provisional management structure and organization chart showing areas of responsibility, relative seniorities and lines of reporting. The proposed staffing plan shall be in conformity with the following:

RESOURCES PROPOSED FOR THE PROJECT – PERSONNEL

The figures indicated below are the minimum number of Project-Personnel required which are to be deployed as per the minimum level of supervision and qualification/experience of site staff is given as follows:

S. No.	Designation of Project Personnel	Minimum Requirement
1	Site Engineer	2
2	Supervisor	1

It is to be noted that:

- i. The contractor shall deploy resources as per the above-mentioned minimum requirement and also confirm to deploy manpower over and above the minimum numbers indicated above, if the work requires so.
- ii. These minimum resources are as per the requirements of the various activities at different stages of works. All resources need not to be mobilized simultaneously, resources as per the requirement of various stages of works shall be mobilized in accordance with the instructions of the Engineer. The decision of the Engineer shall be final and bonding.
- iii. The performance of project personal deployed will be evaluated periodically by Employer during the contract period. In case the performance of any of the personnel is not satisfactory, the contractor shall replace them with good personnel immediately as per the directions of the Engineer.

4.3. Compliance with Technical Specifications

The equipment offered by the bidders must comply with the stipulated technical specifications as mentioned in the tender documents.

4.4. Information of the Technical and Financial Proposal

- a. The Bidder satisfying technical and financial eligibility criteria under Clause 4.1 shall be considered as technically and financially qualified.
- b. The financial proposal of only technically qualified Bidders shall be opened for evaluation.
- c. The Bidder with the lowest quoted price for "**Supply and installation of heavy duty racks at various custody stores and DCOS building (Main Stores) of depot of N-GN corridor**" in the financial quote (L1 bidder) shall be selected for the award of contract.

4.5. Selection of Bidder

After the above evaluation process, the Technically Qualified Bidder, who is declared as L1 (lowest quoted price) may be declared as the selected Bidder ("Selected Bidder") for the Project.

- a. In case, two or more technically qualified bidders quote the same percentage in the Bid, and become Lowest (i.e. L-1), then the tender would be awarded to the bidder who has the highest / higher Average Annual Turnover from 'Similar Works' (as per Minimum Eligibility Criteria defined in Section 4 under "Definition of Similar Work") during the last 3 years ending on the last day of the month preceding the month in which the tender has been floated.
- b. Prior to the expiry of the period of bid validity, NMRC will notify the successful bidder in writing, either through Notice of Award (NOA), that his bid has been accepted.
- c. The NOA would be sent in duplicate to the successful bidder, who will return one copy to NMRC duly acknowledged, signed and stamped by the authorized signatory of the bidder, as an unconditional acceptance of the NOA, within 10 (ten) days from the date of issue of NOA.
- d. No correspondence will be entertained by NMRC from the unsuccessful bidders.
- e. However NMRC will reserve the right for Bid clarification with participating bidders during the course of Tender Evaluation.

4.6. Notice of Award and Execution of Contract Agreement

- a. NMRC will notify the Successful Bidder by a NOA that its bid has been accepted.
- b. The Selected Bidder shall, within 10 (ten) days of the receipt of the NOA, sign and return the duplicate copy of the NOA in acknowledgement thereof along with letter of acceptance of NOA. In the event, the duplicate copy of the NOA duly signed by the Selected Bidder and letter of acceptance of NOA is not received by the stipulated date, NMRC may, unless it consents to extension of time for submission thereof, appropriate the Bid Security of such Bidder as mutually agreed genuine pre-estimated loss and damage suffered by NMRC on account of failure of the Selected Bidder to acknowledge the NOA.
- c. The Successful Bidder shall execute the Contract Agreement within 30 (thirty) days of the letter of acceptance of NOA or such extended period as may be decided by the Corporation.
- d. Failure of the Successful Bidder to comply with the requirement of acknowledgement of NOA shall constitute sufficient grounds for the annulment of the NOA, and forfeiture of the bid security.

4.7. Performance Bank Guarantee / Security Deposit

- a. To fulfill the requirement of performance bank guarantee during the implementation period, the Successful Bidder (herein referred to as the "Contractor") shall deposit **3% of the Contract Price in form of FDR/ DD or unconditional and irrevocable Bank Guarantee bond** issued by a scheduled bank in favor of NMRC, within 30 days from Notice of Award. EMD amount of successful bidder shall be adjusted in the performance bank guarantee, if applicable. For unsuccessful bidder, EMD shall be refunded without any interest. The Performance Guarantee should be valid for a period of 06 (Six) months beyond the warranty period.
- b. It is to note that if contract value increases by more than 25% of the original contract value, the performance bank guarantee shall be increased accordingly.
- c. A Contract agreement will have to be signed by the Contractor at his cost on proper stamp paper. Without performance guarantee by Contractor, Contract agreement shall not be signed.
- d. NMRC reserves the right for deduction of NMRC dues from Contractor's Performance Bank Guarantee/ Security Deposit (interest free) for – Any penalty imposed by NMRC for violation of any terms and conditions of agreement committed by the Contractor.
- e. Any amount which NMRC becomes liable to the Government/Third party due to any default of the Contractor or any of his director/ employees/ representatives/ servant/ agent, etc.
- f. Any payment/ fine made under the order/judgment of any court/consumer forum or law enforcing Contractor or any person duly empowered in his behalf.
- g. Any outstanding payment/ claims of NMRC remained due after completion of relevant actions as per agreement.
- h. Once the amount under above Clause is debited, the Contractor shall replenish the Security Deposit/ Performance Bank Guarantee to the extent the amount is debited within 15 days period, failing which, it shall be treated as Contractor Event of Default and will entitle NMRC to deal with the matter as per the provisions of RFP and Contract Agreement.

4.8. Contract during Proposal Evaluation

RFP for supply and installation of heavy-duty racks at various custody stores and DCOS building (Main Stores) at Depot of N-GN corridor.

- a. Proposals shall be deemed to be under consideration immediately after they are opened and until such time NMRC makes official intimation of award/ rejection to the Bidders. While the Proposals are under consideration, Bidders and/ or their representatives or other interested parties are advised to refrain from contacting by any means, NMRC and/ or their employees/ representatives on matters related to the Proposals under consideration till the time Contract is awarded.
- b. Any effort by a Bidder to influence NMRC in its decisions on e-Bid evaluation, e-Bid comparison or contract award may result in rejection of the Bidder's e-Bid.
- c. In the event of any information furnished by the Contractor is found false or fabricated the minimum punishment shall be debarred/ blacklisting and the legal proceeding may also be initiated.
- d. If the Bidder wishes to bring additional information to the notice of NMRC, he/she can do so in writing. All correspondence/ enquiry should be submitted to the following in writing by fax/ post/courier:

GM (Technical)

Noida Metro Rail Corporation (NMRC) Limited
Block-III, 3rd Floor, Ganga Shopping Complex, Sector-29,
Noida -201301
District Gautam Buddha Nagar, Uttar Pradesh
Email: nmrCNoida@gmail.com

- e. No interpretation, revision, or other communication from NMRC regarding this solicitation is valid unless in writing and signed by the competent authority from NMRC.

4.9. Other Instruction

- a. Canvassing in connection with the tenders is strictly prohibited and the tenders, submitted by Bidder, who resort to canvassing, are liable to be rejected. EMD will be forfeited of those tenders who will be found non serious and if it is felt by the tender committee that the Bidders submitted their tender only to influence the tendering process.
- b. On acceptance of the tender, the name of the accredited representative of the Contractor, who would be responsible for taking instructions from the NMRC or the official deputed by NMRC, shall be communicated to the NMRC or the official deputed by NMRC in writing.

5. Section 5: Special Conditions of Contract (SCC)

SCC Clause	Reference to GCC Sub-Clause No.	Description
1	Sub-Clause 3.2	<p>Functions of Engineer</p> <p>In addition to the duties mentioned in Clause 3.2 of General Conditions of Contract:</p> <ul style="list-style-type: none"> (i) Shall watch and inspect the Works, monitor and examine any material to be used and workmanship employed by the Contractor in connection with the Works; (ii) Shall carry out such duties and exercise such powers vested in the Engineer in accordance with the provisions of the Contract; (iii) Shall issue instructions which in his opinion are necessary for the execution of the Works; and (iv) May issue any other instruction which in his opinion is desirable in connection with the Works. <p>In case The Engineer is employee of any agency hired by the Employer, the Engineer shall take the approval of the Employer for all technical and financial matters otherwise he shall be deemed to have taken the approval of the Employer.</p>
2	Sub Clause 4.2.1	<p>Performance Security</p> <p>The amount of Performance Security for this contract will be 10% of contract. If the contract value increases by more than 25% of the original contract value, the Performance Security will be increased accordingly for complete revised value on every increase.</p>
3	Sub-Clause 4.4	<p>Coordination with other Contractors</p> <p>The contractor for this package shall plan and execute work in coordination and in co-operation with other contractors working for adjacent/other packages</p>
4	Sub-clause 4.5	<p>Sub-contractors</p> <p>The work should not be sublet without the written approval of Engineer in-charge.</p>
5	Sub-Clause 4.10	<p>Sufficiency of Tender</p> <p>The Tenderer shall be entirely responsible for sufficiency of rates quoted by him in his tender.</p> <p>The Contractor (Successful Tenderer) shall be paid for only at quoted/accepted rates for the items of works executed as per BOQ.</p>
6	Sub-Clause 4.11	<p>Access Route</p> <p>All operations for the execution of the Works shall be carried out so as not to interfere unnecessarily with the convenience of the public or the access to public or private roads or footpaths or properties owned by the Employer or by any other person.</p> <p>The Contractor shall select routes, choose and use vehicles so that movement of Contractor's Equipment, Plant and Materials from and to the Site is limited so that traffic is not delayed and damage to highways and bridges is prevented. If there is any delay or damage or injury, the cost of rectification or reconstruction of highways or bridges shall be borne by the Contractor. The Contractor shall indemnify the Employer in respect of all claims, demands, proceedings, damages, costs, charges and expenses whatsoever arising out of or in relation to any such matters</p>

SCC Clause	Reference to GCC Sub-Clause No.	Description
7	Sub-Clauses 4.16 and 6.7	<p>Safety Precautions The Contractor is required to make himself aware of all the requirements of the Employer's Safety, Health and Environmental Manual in this regard and comply with them. The Site Safety Plan shall include detailed policies, procedures and regulations which, when implemented, will ensure compliance with Sub-Clauses 4.16 and 6.7 of General Conditions of Contract.</p> <p>The Contractor shall, from time to time and as necessary or required by the Engineer, produce supplements to the Site Safety Plan such that it is at all times a detailed, comprehensive and contemporaneous statement by the Contractor of his site safety and industrial health obligations, responsibilities, policies and procedures (under the laws of India) or as stated in the Contract or elsewhere relating to work on Site. If at any time the Site Safety Plan is, in the opinion of the Engineer, insufficient or requires revision or modification to ensure the security of the Works and the safety of all workmen upon, and visitors to the Site, the Engineer may instruct the Contractor to revise the Site Safety Plan. The Contractor shall, within 14 days, submit the revised plan to the Engineer for review.</p> <p><u>The contractor shall provide necessary barriers warning signals and other safety measures to avoid accidents.</u></p> <p>He shall also indemnify department against claims for compensation arising out of negligence in this respect. Nothing in these specifications shall be construed to relieve the contractor of his responsibility for the design, manufacture and installation of the equipment with all accessories in accordance with applicable statutory regulations and safety codes in force from the safety angle.</p>

8	Sub-Clause 4.17	<p>Protection of the Environment</p> <p>The Contractor shall maintain ecological balance by preventing deforestation, water pollution and defacing of natural landscape. The Contractor shall, so conduct his cleaning operations, as to prevent any avoidable destruction, scarring or defacing of natural surroundings in the vicinity of work. In respect of ecological balance, the Contractor shall observe the following instructions</p> <p>(a) Where destruction, scarring, damage or defacing may occur as a result of operations relating to construction and maintenance activities, the same shall be repaired, replanted or otherwise corrected at Contractor's expense. All work areas shall be smoothed and graded in a manner to confirm to natural appearance of the landscape as directed by the Engineer.</p> <p>(b) All trees and shrubbery, which are not specifically required to be cleared or removed for cleaning purposes, shall be preserved and shall be protected from any damage that may be caused by Contractor's cleaning operations and equipment. The removal of trees or shrubs will be permitted only after prior approval by the Engineer. Trees shall not be used for anchorage. The Contractor shall be responsible for injuries to trees and shrubs caused by his operations. The term "injury" shall include, without limitation, bruising, scarring, tearing and breaking of roots, trunks or branches. All injured trees and shrubs shall be restored as nearly as practicable, without delay, to their original condition at Contractor's expenses.</p> <p>(c) The Contractor shall provide all necessary access, assistance and facilities to enable the Engineer and the Employer to monitor and conduct tests to verify that the Site Environmental Plan is being properly and fully implemented</p>
9	Sub-Clause 4.18	<p>Electricity and Water</p> <p>Electricity and water shall be arranged by the contractor on his own and at his cost.</p> <p>If available, the Employer may provide Water supply and Electricity on chargeable basis. The contractor shall make his own arrangements to tap the Electricity from the nominated and existing sockets/ points. The contractor shall tap the Electricity as per IE Rules & IE Act (Latest) duly complying all safety precautions and under following conditions:</p> <p>(a) The contractor shall submit full scheme for the requirement of Electricity & water. If scheme mentions Electricity requirement which is beyond the capacity of the Employer, in that case the contractor shall make his own arrangements/ alternative arrangements.</p> <p>(b) The Contractor should make his own arrangements to draw the water from the available water point to the working place without affecting the premises</p>

10	Sub-Clause 4.19	<p>Employer Supplied Machinery and Materials The Employer will not provide any machinery or materials under the Contract.</p>
11	Sub Clause 4.27	<p>Security of the Site The Contractor shall take all measures necessary to ensure such security, including exercising control over all persons and vehicles which are employed or engaged on the Site or in connection with the Works or the other works comprising the Project and with the security arrangements applicable to any other site within the Project.</p> <p>The Contractor shall arrange the issue of passes for the admission of all persons and vehicles to the Site or to any part thereof and may refuse admission to or remove from the Site any person or vehicle failing to show an appropriate pass on demand to any duly authorized person.</p> <p>If required by the Engineer, the Contractor shall submit a list identifying all persons to whom passes have been issued together with two photographs of each person and all entities to which a pass has been issued in respect of any vehicle and shall satisfy the Engineer of the bonafides of any such person or entity.</p> <p>The Contractor shall not, without the written permission of the Engineer or otherwise in accordance with the Contract, allow access to the Site to any person unless the presence on Site of such person is necessary in connection with the execution of the Works or with the discharge of the duties of any relevant authority.</p> <p>For the purposes of this Clause only, "Site" shall include off-Site places of manufacture or storage and the Contractor's Work Areas and shall include, areas provided to the Contractor by others.</p>
12	Sub-Clause 5.3	<p>Submission of Documents The Contractor shall submit the drawings and documents, warranty certificates, Material Test certificate of supplied items wherever required or as required by the Engineer in charge.</p> <p>This submittal shall be made sufficiently before the Works are to be carried out to give the Engineer and the Employer reasonable time to examine the drawings or other documents, to prepare comments and for any changes to be accommodated by the Contractor.</p> <p>Where the consent of the Engineer is required, the Engineer shall notify the Contractor in writing of his decision either within such period as may expressly be stipulated in the Contract or otherwise within a reasonable time.</p>

13	Sub-Clause 6.0	<p>Training of Contractor's Employees / Staff / Workers Contractor shall provide a training / workshop on Safety, Health & Environment (SHE) to all its workers/ employees/ sub-contractors at the time of induction as per required of condition of contract on Safety, Health and Environment. Before posting any of his workers/ staff/ employees/ sub-contractors, the contractor shall give a certificate that the said person had undergone the requisite SHE training.</p>
14	Sub-Clause 6.4	<p>Labour Laws : The Contractor shall, if required by the Employer, deliver to the Engineer or to his office; a return in detail, in such form and at such intervals as the Employer may prescribe, showing the number of labour employed in different categories by the Contractor for the entire work.</p>
15	Sub-Clause 6.6	<p>Housing Facilities The Contractor shall have to make his own arrangements for housing facilities for his staff.</p>
16	Sub-Clause 6.7	<p>Health and Safety Contractors are required to have tie-up with well equipped reputed hospitals having facilities of MRI, CT Scan, Ultrasound, Blood Bank, specialist Doctors like neurosurgeon, orthopedic as mandatory requirement and fire station located in the neighborhood for attending to the casualties promptly and emergency vehicle kept on standby duty during the working hours for the purpose.</p>
17	Sub Clause 7.0	<p>Quality Control The Contractor shall appoint a suitably qualified and experienced person, not otherwise engaged in the performance of the Contract, to act as manager of the quality assurance system and shall provide such other personnel and resources as required to ensure effective operation of the quality assurance system. The said manager shall carry out audits of the application of the quality assurance system, and ensure effective quality control and delivery of quality assurance.</p> <p>The Contractor shall provide all necessary access, assistance and facilities to enable the Engineer to carry out surveillance visits both on and off the Site to verify that the quality assurance system is being properly and fully implemented. No extra payment shall be made in this regard and the cost of the Work under this element shall be deemed to be included in the Contract Price.</p>

18	<p>Sub-Clause 11.1</p> <p>Sub-Clause 11.1.1</p> <p>Sub-Clause 11.1.4</p>	<p>Contract Price & Payment In respect of All Inclusive Contract The Contract Price, subject to any adjustment thereto in accordance with the contract conditions, shall be all inclusive (including all taxes, duties, royalties etc.)</p> <p>Change in Taxes Duty (a) "Change in Taxes/Duties/Levies" means the occurrence or coming into force of the following, at any time after the date of submission of tender. (i) Any new tax which is imposed on Composite Works Contractors applicable on Metro Project. (ii) Change in the rate of GST on Composite Works Contractors applicable on Metro Project as Per GST Act.</p> <p>The Contract Price shall be adjusted due to any of the above two conditions. Adjustment in contract price will be applicable up to the stipulated date of completion of work including the extended period of completion where such extension has been granted under sub clause 8.4.1 of GCC or it is specifically mentioned that extension is with adjustment for changes as stated above.</p> <p>(c) If the extension of contract period is on account of contractor's fault under Sub-clause 8.4.3 of GCC, no compensation shall be made towards upward revision towards "change in Taxes/Duty (taking place during the said extended contract period)" as mentioned at Sl. No. (a) (i) & (ii) above, during the original contract period or extended contract period shall be on employer's account.</p> <p>(d) Any other changes (except on account of clause (a) (i) & (ii) above) in existing taxes/new taxes on supply of materials/services/works etc. will not be considered and its impact shall be considered covered in the price variation clause provided in the Contract and in Contract where Price Variation clause is not provided, the impact on any other change (except on account of clause(a) (i) & (ii) above in existing taxes/new taxes on supply of materials/services/works etc. will be deemed to be included in the quoted contract price.</p> <p>(e) Also, the contract price shall not be adjusted on account of fluctuations in the rates of exchange between the foreign currencies of the contract and Indian rupees from the last date of submission of tender.</p>
19	Sub clause 11.1.3	<p>Price Variation This is a fixed price contract and no Price Variation is admissible in this contract.</p>
20	Sub-Clause 11.2	<p>Advance No Advance is admissible in this contract.</p>
21	Sub-Clause 11.6	<p>Payment For the purpose of On-account payment, the contractor shall submit detailed activities carried out as per BOQ recorded in Measurement sheets, Abstract sheets along with recorded bill for the item actually executed for checking and payment. Payment will be effected based on unit rates as approved in the Bill of Quantities.</p> <p>TERMS OF PAYMENTS</p> <ul style="list-style-type: none"> • The standard payment terms subject to recoveries, if any, by way of liquidated damages will be as under. <ul style="list-style-type: none"> A) 70% payment of the supply value of equipment will be made on Delivery at NMRC sites. B) 30% payment will be made after complete installation, testing and commissioning

		<p>Following documents to be provided for 70% payment</p> <ul style="list-style-type: none"> • Order Copy • E-way Bill • Tax invoice • Delivery Challan • Storage insurance for 60 days <p>Following documents to be provided for 30%payment</p> <ul style="list-style-type: none"> • One set of completion drawings. • Acceptance certificate from NMRC
22	Sub-Clause 18.1	<p>Notices and Instructions</p> <p>The Contractor shall furnish to the Employer/Engineer the postal address of his office. Any notice or instructions to be given to the Contractor under the terms of the contract shall be deemed to have been served on him if it has been delivered to his authorized agent or representative at site or if it has been sent by registered post to the office, or to the address of the firm last furnished by the Contractor.</p> <p>In addition, the Contractor may set up field offices at convenient and approved locations for co-ordination and for monitoring the progress of fieldwork at his own cost.</p>

6. Section 6: Technical Specification of Heavy Duty Racks (Please refer Annexure -6)

6.1 Sample Testing: -

1. NMRC will reserve the right for testing of physical samples to be submitted during technical evaluation/execution of work.
2. The samples will be sent/tested from Government approved Lab for various technical parameters. All cost for such testing shall be borne by the bidder.

7. Section 7: Draft Contract Agreement

THIS AGREEMENT made on the.....day of2021 at Noida, District Gautam Buddha Nagar, Uttar Pradesh Between **Noida Metro Rail Corporation Limited** (Hereafter referred to as "NMRC"), a company incorporated under Companies Act 2013, vide corporate identification Number: U60231UP2014SGC066849 and having its registered office at **Block-III, 3rd Floor, Ganga Shopping Complex, Sector-29, Noida -201301, District Gautam Buddha Nagar, Uttar Pradesh, India** represented by.....of the company, by virtue of his designation and authorization by **Smt. Managing Director, NMRC** (hereinafter called as the "Purchaser"), which expression shall unless excluded by or repugnant to the context or meaning thereof be deemed to include its successors and permitted assigns) of the one part,

AND

..... having its registered office at
.....,represented by
.....(herein after called the "**Contractor**", which expression shall unless excluded by or repugnant to the context or meaning thereof be deemed to include its successors and permitted assigns) of the other part. WHEREAS the Purchaser desires that the Works known as the "....."should be executed by the Contractor, and has accepted a contract by the Contractor for the execution and completion of these Works.

The Purchaser and the Contractor agree as follows:

1. In this Agreement words and expressions shall have the same meanings as are respectively assigned to them in the Contract documents referred to.
2. The following documents shall be deemed to form and be read and construed as part of this Agreement-

Reference:

- (i) Tender No. Dated.....
- (ii) Bid Documents duly accepted and submitted by dated.....
- (iii) The Bidding Documents which include all the Sections specified below:
 - a. Section 1: General Information
 - b. Section 2: Terms of Reference
 - c. Section 3: Instructions to Bidders
 - d. Section 4: Qualification, Evaluation and Selection Process
 - e. Section 5: Special Conditions of contract (SCC)
 - f. Section 6: Technical Specification of Heavy Duty Racks
 - g. General Conditions to Contract (GCC)
 - h. Condition of Contract on Safety, Health & Environment Management
 - i. Amendment/ Modification, if any
- (iv) Notice of Award(.....) issued by NMRC
- (v) Letter of Acceptance of NOA (.....)given by..... to NMRC
- (vi) Any other admitted correspondence documents between NMRC and the Bidder.

3. Duration of Contract

The Corporation intends to appoint a Contractor to NMRC for a period of 6 months, which may be extended for a further period of 15 days after reviewing the performance of the Contractor and depending upon the requirement and administrative convenience of NMRC in mutual agreement with the Bidder.

4. Price Schedule

NMRC shall be as quoted by the contractor as part of financial bid i.e. INR _____.
As per letter of acceptance no _____ dt _____.

5. The courts at District Gautam Buddha Nagar, Uttar Pradesh shall have the exclusive jurisdiction to try all disputes arising out of this agreement between the parties.
6. In consideration of the payments to be made by the Purchaser to the Contractor as specified in this Agreement, the Contractor hereby covenants with the Purchaser to execute the Works and to remedy defects therein in conformity in all respects with the provisions of the Contract and Notice of Award issued. **"Any conditions, deviation, assumption, exclusion, suggestion of alternative clauses, request of amendments in conditions & specifications of work submitted by bidders along with his Technical Bid or Financial bid, which is different from the Tender Document, Corrigendum, Addendum uploaded by NMRC on the E-Tender Portal (<http://etender.up.nic.in>) and any other correspondence in this regard, shall not be treated as a part of the contract Agreement & shall not be binding upon NMRC in anyway whatsoever at any stage of work during execution or thereafter."**
7. The Purchaser hereby covenants to pay the Contractor in consideration of the execution and completion of the Works, the Contract Price or such other sum as may become payable under the provisions of the Contract at the times and in the manner prescribed by the Contract and NOA.

IN WITNESS where of the parties hereto have caused this Agreement to be executed in accordance with the laws of India on the day, month and year specified above.

For and on behalf of the Contractor
Signature of the authorized official

For and on behalf of the Purchaser
Signature of the authorized official

Name of the official

Name of the official

Stamp/Seal of the contractor

Stamp/Seal of the Purchaser

In the presence of:

In the presence of:

Sign of Witness1 _____ Sign of Witness1 _

Name _____

Name _____

Address _____

Address _____

RFP for supply and installation of heavy-duty racks at various custody stores and DCOS building (Main Stores) at Depot of N-GN corridor.

Sign of Witness2 _____

Sign of Witness2 _____

Name _____

Name _____

Address _____

Address _____

8. Section: 8 Appendix to Form of Tender and Forms

8.1. Appendix 1: Metro Alignment

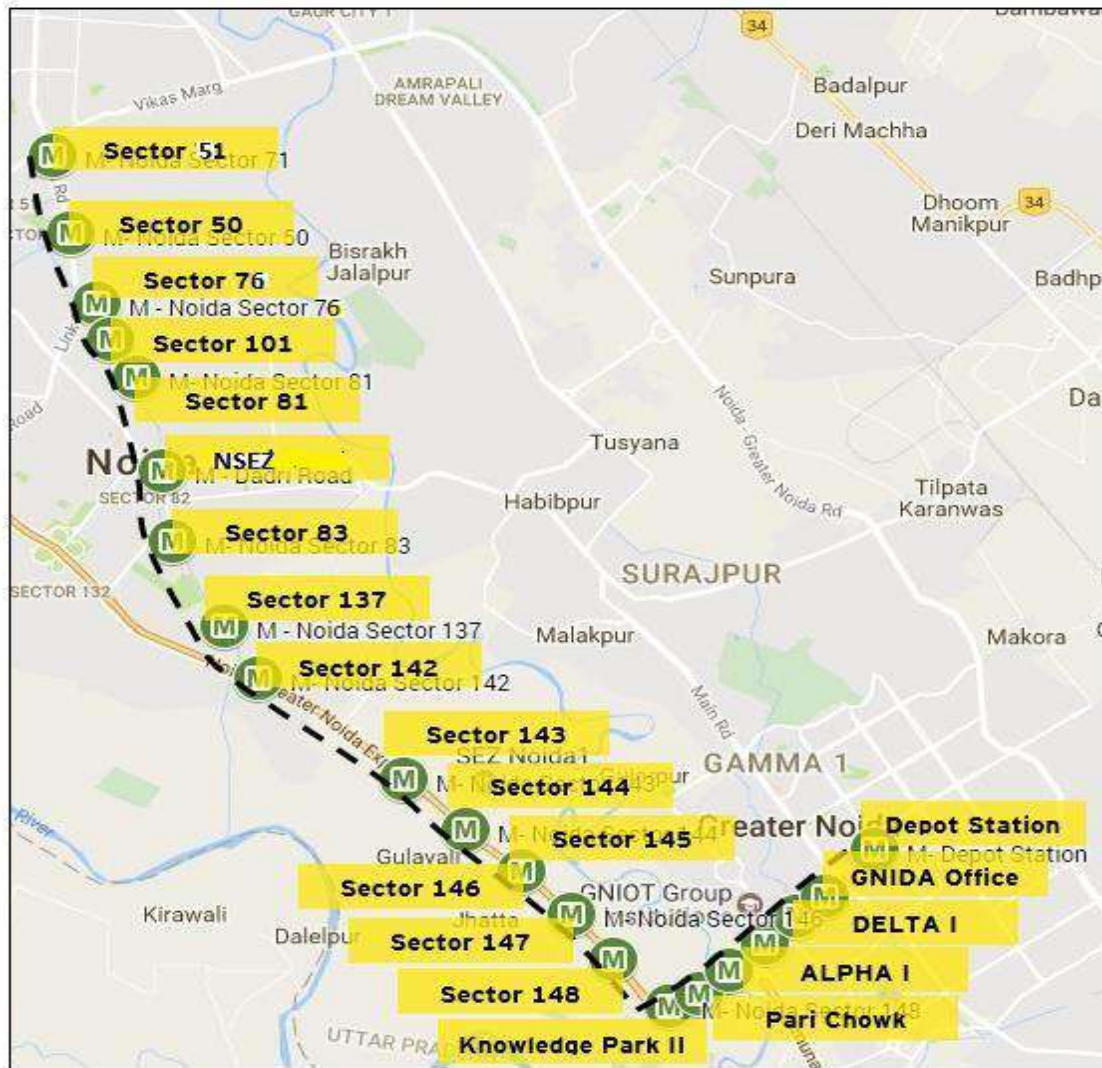

Fig: The Upcoming Metro Line

Please Note: The map shown above is indicative (not to scale)

Locations shall be decided for Supply and Installation of Heavy duty racks in various Custody Stores & Main Stores (DCOS Building) Stores at Depot of N-GN Corridor

S.NO.	Name of the Location
1.	OHE Store at Depot
2.	Electrical & Mechanical store at Depot
3.	Heavy Maintenance Room at Depot
4.	PSI Stores at Depot
5.	DCOS Building(Main Stores) at Depot

RFP for supply and installation of heavy-duty racks at various custody stores and DCOS building (Main Stores) at Depot of N-GN corridor.

8.2. Form 1: Letter of Proposal Submission

[Location, Date]

To

GM (Technical)

Noida Metro Rail Corporation (NMRC) Limited
Block-III, 3rd Floor, Ganga Shopping Complex,
Noida -201301,
District Gautam Buddha Nagar, Uttar Pradesh

Subject: Supply and installation of heavy duty racks at various custody stores and DCOS building (Main Stores) of depot of N-GN corridor.

Dear Sir,

We, the undersigned, offer to provide the Supply and installation of heavy duty racks at various custody stores and DCOS building(Main Stores) of depot of N-GN corridor in accordance with your RFP Document dated [Insert Date] and our Proposal. We are hereby submitting our Technical and Financial Proposal, in a sealed envelope. We confirm that we have read the RFP Document in totality and abide by the terms and conditions stated in the document.

We have filled the complete information correctly in Bid detail.

We hereby declare that all the information and statements made in this Proposal are true and accept that any misinterpretation contained in it may lead to our disqualification. Our Proposal is binding upon us.

We understand you are not bound to accept any Bid you receive.

Yours Sincerely,

Authorized Signature [In full and initials]:

Name and Title of Signatory:

Name and address of Firm:

8.3. Form 2: Firm Details

1.	<p>Title and name of the Project: Supply and installation of heavy duty racks at various custody stores and DCOS building (Main Stores) of depot of N-GN corridor</p>
2.	<p>State the structure of the Bidder's organization (Bidders to complete/delete as appropriate)</p>
3.	<p>For Bidders who are individual companies or firms, state the following: Name of Company or firm: Legal status: (e.g. incorporated private company, proprietorship, etc.) Registered address: Year of incorporation..... Principal place of business: Contact person: Contact person's title: Address, telephone, facsimile number and e-mail ID of contact person: </p>
4.	<p>GST Registration No. (Attach Documentary Proof):</p>
5.	<p>PAN (Attach Documentary Proof):</p>
6.	<p>Employees Provident Fund No. (Attach Documentary Proof): </p>
7.	<p>Employees State Insurance Acts in India No. (Attach Documentary Proof): </p>
8.	<p>Authorized Representative </p>

8.4. Form 3: Capability Statement

It is Compulsory for the bidder to fill this statement and the bidder must upload those document that support this statement

Tender Reference No: _____

Name of Work: _____

Name of Bidder: _____

S. No.	ELIGIBILITY CRITERIA	(To be filled by the Bidder)
1	Sole proprietorship/registered partnership firm/ public limited company/ private limited company. The Firm and the company should be registered in India. The firm and the companies should be registered in India. The firm and the companies must be BIFMA Level 3 certified, ISO 2001, ISO 45001 and EN 15512 certified. The firm must have a regional office in Dehi-NCR region.	Yes/ No
2	<p>The Bidder/OEM should have successfully completed in India during last 7 (Seven) years period ending last day of month previous to the one:</p> <p>I. One order of similar nature of value not less than Rs. 1,54,05,000/-(Rupees One crore fifty four lakh five thousand only) or</p> <p>II. Two orders of similar nature of value not less than Rs. 96,28,000/-(Rupees Ninety six lakh twenty eight thousand only) each or</p> <p>III. Three orders of similar nature of value not less than Rs. 77,03,000/-(Rupees Seventy seven lakh three Thousand only)each</p> <p>Definition of Similar Works – Experience in Supply and Installation of Heavy duty racks /Storage in Stores/warehousing facilities at Railways/Metros/Airports/Bus Depots/Office Premises/Shopping Malls/ Hospitals/ Hotels/Institutes/Reputed Private Firms utilizing similar work. Bidder can submit the credential of OEM along with MAF (Manufacturer Authorization letter as per annexure 7) for participation in this particular tender.</p>	7 Years

S. No.	ELIGIBILITY CRITERIA	(To be filled by the Bidder)	
3	The Bidder should have in the last 3 (Three) Financial Years preceding the Bid Due Date - i. Minimum average annual turnover of Rs. 1.54 Crore/-(Rupees One crore Fifty-Four Lakh Only)	FY 2020-21	
		FY 2019-20	
		FY 2018-19	
		Total	
4	The Bidder should have Positive Profit before Tax in at least 2 (two) years, out of the last 5 (five) Financial Years (2020-21, 2019-20, 2018-19, 2017-18, 2016-17)	FY 2020-21	
		FY 2019-20	
		FY 2018-19	
		FY 2017-18	
		FY 2016-17	
5	The Bidder should be registered with the Goods and Services Tax Authorities.		
6	The Bidder should not have been blacklisted/ banned/ declared ineligible for corrupt and fraudulent practices by the Government of India/ any State Government/ Government Agency and Supreme court and contracts have been terminated/ foreclosed by any company / department due to non- fulfillment of Contractual obligation in last 5 (five) financial years.		
7	The Bidder should have minimum Net Worth of Rs 38.51 Lakh/-(Rupees Thirty Eight Lakh Fifty One Thousand only) in last audited Financial Year.	FY 2020-21	
8	The bidder should have minimum net current assets of Rs 27.51 Lakhs (Rupees Twenty-Seven Lakh Fifty-One Thousand Only) in the last audited financial year.	FY 2020-21	

RFP for supply and installation of heavy-duty racks at various custody stores and DCOS building (Main Stores) at Depot of N-GN corridor.

8.5. Form 4: Work Experience

The following format shall be used for statement of experience of Bidder/OEM:

Details of orders for the quoted item executed should be furnished in the following format.

SN	Similar Contract description	Contract Identification Number	Award date & Completion date	Employer's Name, address, telephone number, e- mail etc	Completion cost	Value of similar work in completed work
1						
2						
3						
4						
	Add required number of rows					

Authorized signatory

Name:

Date:

Name of the Bidder with seal

NOTE:

1. Only the value of contract as executed by the applicant/member in his own name should be indicated.
2. The tenderer shall upload details of work executed by them in the prescribed format for the works to be considered for qualification of work experience criteria. Documentary proof such as completion certificates from the client clearly indicating the nature/scope of work, actual completion cost and actual date of completion for such work should be uploaded.

In case work is executed for private client documentary proof such as copy of work order, Bill of quantities, Bill wise details of payment received certified by CA, TDS certificates for all the payments received, copy of final/ last bill paid by the client should be uploaded. The offers submitted without this documentary proof will not be evaluated.

3. Value of successfully completed portion of any ongoing work up to the last day of the previous month of tender submission will also be considered for qualification of work experience criteria.
4. For completed works, value of work done shall be updated to the last day of the previous month of tender submission price level assuming 5% inflation for Indian Rupees every year and 2% for foreign currency portions per year. The exchange rate of foreign currency shall be applicable 28 days before the submission date of tender.
5. If the above work(s) comprise(s) other works also, then client's certificate clearly indicating the amount of work done in respect of the "similar work" shall be furnished by the tenderer in support of work experience along-with their tender submissions.

8.6. Form 5: Financial Capability Details

Bidder should submit their financial details as per the following:

This is to certify that the details of M/s

 having registered office at
for last five years is as below:

S.No.	Financial year	Name of the Bidder	Turnover (INR)
1.	2020-21		
2.	2019-20		
3.	2018-19		
	Average Annual Turnover		

S.No.	Financial year	Name of the Bidder	Profitability (INR)
1.	2020-21		
2.	2019-20		
3.	2018-19		
4.	2017-18		
5.	2016-17		

S.No.	Financial Year	Name of Bidder	Net Worth
1	2020-21		

S.No.	Financial Year	Name of Bidder	Liquidity
1.	2020-21		

RFP for supply and installation of heavy-duty racks at various custody stores and DCOS building (Main Stores) at Depot of N-GN corridor.

Certificate of the Chartered Accountants/Statutory Auditors

Based on Audited Accounts and other relevant documents of _____(Name of Bidder), we M/s _____, Chartered Accountants/ Statutory Auditors, certify that the above information pertaining to FY 2016-17, FY 2017-18, FY 2018-19, FY 2019-20 and FY 2020-21 is correct.

Signature and Seal of
Chartered Accountants/Statutory Auditors
(With membership no. and UDIN number)

Authorised Signatory

(Name & Designation of Authorised Signatory)

In case the Financial Statements for the latest financial year are not audited and therefore the Bidder cannot make it available, the Bidder shall give an undertaking to this effect and the statutory auditor/charted accountant shall certify the same. In such a case, the Bidder shall provide the Audited Financial Statements for 2 (two) years preceding the year for which the Audited Financial Statement is not being provided. Also, pertaining to latest financial year, the bidder shall submit an affidavit certifying that "The Annual Accounts have not been audited so far which is certified by CA also."

NOTE:

1. All such documents reflect the financial data of the bidder and not that of sister or parent company.
2. The financial data in above prescribed format shall be certified by CA/ Company Auditor under his signature and stamp in original along with membership no.
3. The Bidder shall provide the audited annual financial statements as required.

RFP for supply and installation of heavy-duty racks at various custody stores and DCOS building (Main Stores) at Depot of N-GN corridor.

8.7. Form 6: Memorandum

Name of Work: Supply and installation of heavy duty racks at various custody stores and DCOS building (Main Stores) of depot of N-GN corridor.

I/We agree to keep the quoted rate open for acceptance for 180 days from the due date of submission thereof and not make any modification in its terms and conditions.

I/We hereby declare that I/We shall treat the quotation documents, drawings and other records connected with the works as secret/ confidential documents and shall not communicate information derived there from to any person other than the information in any manner prejudicial to the safety of NMRC.

Signature of the bidder with seal
Dated:

Witness:

Address:

Occupation

8.8. Form 7: Undertaking

Name of Work: Supply and installation of heavy duty racks at various custody stores and DCOS building (Main Stores) of depot of N-GN corridor.

I confirm that M/S.....

- a. Have not been banned /declared ineligible for corrupt and fraudulent practices by any government/government-undertaking/ semi-government/ govt. controlled institutions in India, any court of law having jurisdiction in India and do not have any disciplinary proceedings or pending litigations for the past 5 (five)years.
- b. Does not have any pending litigation & non-performing contracts during last 5 (five) years. Further, has not been barred by any government/government-undertaking/ semi-government/ govt. controlled institutions/ private organizations in India.
- c. Have not abandoned any work in last 5 (five) years.
- d. Have not delayed in similar work completion during orders executed in last 5 (five) years.
- e. Does not ever been terminated due to poor performance.
- f. Have not suffered Bankruptcy/ insolvency in last 5 (five) years.
- g. Have not been blacklisted/ Debarred by any organization.
- h. Have not submitted any misleading information in the Bid.
- i. Are financially sound to perform the work.
- j. Have not been involved in any illegal activity and/or have not been charge sheet for any criminal act during last 5 (Five) Year.

Signature of the bidder with seal

Dated:

Witness:

Address:

Occupation

8.9. Form 8: Power of Attorney

(To be on non-judicial stamp paper of appropriate value as per Stamp Act relevant to place of execution.)

Power of Attorney to be provided by the Bidding Company in favor of its representative as evidence of authorized signatory's authority.

Know all men by these presents, We(name and address of the registered office of the Bidding Company) do hereby constitute, appoint and authorize Mr./Ms.....(name and residential address) who is presently employed with us and holding the position of _____, as our Attorney to do in our name and our behalf all or any of the acts, deeds or things necessary or incidental to submission of our Bid for **Supply and installation of heavy duty racks at various custody stores and DCOS building(Main Stores)at Depot of N-GN Corridor** in response to the RFP Document dated _____ issued by Noida Metro Rail Corporation ("NMRC" or "the Corporation"), including signing and submission of the Bid and all other documents related to the Bid, including but not limited to undertakings, letters, certificates, acceptances, clarifications, guarantees or any other document which the Corporation may require us to submit. The aforesaid Attorney is further authorized for making representations to the NMRC or any other authority, and providing information / responses to the NMRC, representing us in all matters before the NMRC, and generally dealing with the Corporation in all matters in connection with our Bid till the completion of the bidding process as per the terms of the RFP Document and further till the Contract is entered into with the NMRC and thereafter till the expiry of the Contract.

We hereby agree to ratify all acts, deeds and things done by our said attorney pursuant to this Power of Attorney and that all acts, deeds and things done by our aforesaid attorney shall be binding on us and shall always be deemed to have been done by us.

All the terms used herein but not defined shall have the meaning ascribed to such terms under the RFP Document.

Signed by the within named
..... [Insert the name of the executants company]
Through the hand of
Mr.
duly authorized by the Board to issue such Power of Attorney
Dated this day of

Accepted
.....
Signature of Attorney
(Name, designation and address of the Attorney)

Attested
.....
(Signature of the executants)
(Name, designation and address of the executants)

.....
Signature and stamp of Notary of the place of execution

Common seal of has been affixed in my/our presence pursuant to Board of Director's Resolution dated.....

WITNESS

1.

(Signature)

Name

Designation.....

2.

(Signature)

Name

Designation.....

Notes:

- (1) The mode of execution of the power of attorney should be in accordance with the procedure, if any, laid down by the applicable law and the charter documents of the executant(s) and the same should be under common seal of the executant affixed in accordance with the applicable procedure. Further, the person whose signatures are to be provided on the power of attorney shall be duly authorized by the executants(s) in this regard.
- (2) In the event, power of attorney has been executed outside India, the same needs to be duly notarized by a notary public of the jurisdiction where it is executed.
- (3) Also, wherever required, the executants(s) should submit for verification the extract of the charter documents and documents such as a board resolution / power of attorney, in favour of the person executing this power of attorney for delegation of power hereunder on behalf of the executant(s).

RFP for supply and installation of heavy-duty racks at various custody stores and DCOS building (Main Stores) at Depot of N-GN corridor.

8.10. Form 9: Saleable Form for Tender Document

Job No.

The required fee of tender form has been deposited in _____ Bank A/c No. _____ RTGS/NEFT and the scanned copy of UTR receipt with Transaction Id is being enclosed with E-tender documents. If the copy of UTR receipt is not uploaded with the E-tender the tender shall be rejected.

DETAILS OF ERNEST MONEY ATTACHED

The required amount of Earnest money has been deposited in _____ Bank A/c No. _____ RTGS/NEFT and the scanned copy of UTR receipt with transaction Id is being enclosed with E-tender documents. If the copy of UTR receipt is not uploaded with the E-tender the tender shall be rejected.

BIDDER

8.11. Form 10: Undertaking pertaining to Personnel

- We confirm to deploy Project Personnel required to achieve progress of work as per approved construction of work program and conditions mentioned in the tender document.
- The contractor shall deploy resources as per the mentioned minimum requirement in the tender and confirm to deploy manpower over and above the minimum numbers indicated above, if the work requires so.
- These minimum resources are as per the requirements of the various activities at different stages of works. All resources need not to be mobilized simultaneously, resources as per the requirement of various stages of works shall be mobilized in accordance with the instructions of the Engineer. The decision of the Engineer shall be final and bonding.
- The performance of project personal deployed will be evaluated periodically by Employer during the contract period. In case the performance of any of the personnel is not satisfactory, the contractor shall replace them with good personnel immediately as per the directions of the Engineer.

Date:

Signature with Stamp/Seal

8.12. Form 11: Declaration of Refund of Earnest Money

**Noida Metro Rail Corporation (NMRC) Limited
Block-III, 3rd Floor,
Ganga Shopping Complex, Sector-29, Noida -201301,
District Gautam Buddha Nagar, Uttar Pradesh, India**

1 Bidder Name	
2 Bidder Address	
3 Bank Name	
4 Bank Branch	
5 A/c No	
6 IFSC Code	
7 PAN No.	
8 Tin/TAN No.	
9 GST No.	
10 Phone No.	
11 Mobile No.	
12 Email-Id	
For Office Use Only	
13 Party Unique Id	

The above provided information is true to the best of my knowledge.

Date:

Signature with Stamp/Seal

RFP for supply and installation of heavy-duty racks at various custody stores and DCOS building (Main Stores) at Depot of N-GN corridor.

8.13. Form 12: Bid Offer/ BOQ(Format)

To

GM (Technical)

Noida Metro Rail Corporation (NMRC) Limited

Block-III, 3rd Floor, Ganga Shopping Complex

Noida -201301,

District Gautam Buddha Nagar, Uttar Pradesh

THIS FORM IS NOT TO BE FILLED. THE BIDDERS ARE REQUIRED TO FILL THE FINANCIAL PROPOSAL IN XLS FORMAT AFTER DOWNLOADING THE FORM FROM THE E-PROCUREMENT WEBSITE FOR THIS TENDER DOCUMENT

Sub: Supply and installation of heavy duty racks at various custody stores and DCOS building (Main Stores) at depot of N-GN corridor.

Dear Sir,

I/we have read and examined the RFP document, general terms and conditions.

I/we hereby quote for the Total Price for **Supply and installation of heavy duty racks at various custody stores and DCOS building (Main Stores) at Depot of N-GN Corridor** as specified below, payable by NMRC.

BIDDER

Price Schedule

Price Schedule for Supply and Installation of heavy duty racks at various custody stores and DCOS building (Main Stores) at Depot of N-GN Corridor

Sr. No	Drawings	STORES AREA/Type	Total Qty	Units	Quoted RATE (Excluding GST) Per unit In Figures To be entered by the Bidder Rs. P)*	Quoted RATE (Including GST)Per unit In Figures To be entered by the Bidder Rs. P	Total Quoted Amount (including GST) by Bidder for required Quantity (In Figures)
1	Annexure-1	Boltless Single Tier with Partition	4	Each			
2	Annexure-1	Long span Single Tier Racks	7	Each			
3	Annexure-1	Cantilever Racking System	11	Each			
4	Annexure-2	Long span Single Tier Racks	15	Each			
5	Annexure-3	Boltless Single Tier Racks	6	Each			
6	Annexure-3	Long span Single Tier Racks	13	Each			
7	Annexure-4	Long span Single Tier Racks	15	Each			
8	Annexure-5	Long span Multitier Tier Racks	25	Each			
9	Annexure-5	Long span Multitier Tier Racks	21	Each			
10	Annexure-5	Long span Multitier Tier Racks	21	Each			
11	Annexure-5	Long span Multitier Tier Racks	21	Each			
12	Annexure-5	Long span Multitier Tier Racks	18	Each			
13	Annexure-5	Long span Multitier Tier Racks	10	Each			
14	Annexure-5	Boltless Multitier Tier Racks	12	Each			
15	Annexure-5	Heavy Duty Single Tier Racks	21	Each			
Total Amount (Including GST) (In Rupees) in Figures							
Total Amount (Including GST) (In Rupees) in Words							

*Taxes as applicable at the time of supply of goods or services will prevail.

RFP for supply and installation of heavy-duty racks at various custody stores and DCOS building (Main Stores) at Depot of N-GN corridor.

Please Note: The Bidder is required to fill only blue cells in the BOQ as highlighted above

Note:

- a. The Bidder with the lowest quoted cost for Supply and Installation of heavy duty racks at various custody stores and DCOS building(Main Stores)at Depot of N-GN Corridor in the financial quote (L1 bidder) shall be selected for the award of contract.
- b. The Bidder shall be required to quote the amount in the BOQ.
- c. The Bidder shall abide by the approved makes mentioned in the tender document.
- d. The Financial Bid submitted is unconditional (inclusive of all taxes including GST, duties, levies, etc. as applicable) and fulfills all the requirements of the TOR Document.

- e. We have completely read and understood the Bid Document. The Financial Tender submitted is unconditional and fulfills all the requirements of the Tender Document.

We understand you are not bound to accept any Proposal you receive.

Signature and Name of the Authorized Person

NAME OF THE BIDDER AND SEAL

RFP for supply and installation of heavy-duty racks at various custody stores and DCOS building (Main Stores) at Depot of N-GN corridor.

8.14. Form 13: MAF (Manufacturer's Authorization Form)

To

GM (Technical)

Noida Metro Rail Corporation (NMRC) Limited
Block-III, 3rd Floor, Ganga Shopping Complex, Sector-29,
Noida -201301
District Gautam Buddha Nagar, Uttar Pradesh

Dear Sir,

TENDER:

We, _____, who are established and reputable manufacturers of _____, having factories at _____ and _____, hereby authorize Messrs. _____ (Authorized Dealer/Sole Distributor/Supplier) _____ (name and address of agents) to bid, negotiate and conclude the contract with you against Tender No. _____ for the above goods manufactured by us. No company or firm or individual other than M/s _____ are authorized to bid, negotiate and conclude the contract in regard to this business against this specific tender.

We hereby extend our full guarantee and warranty as per the conditions of tender for the goods bided for supply against this tender by the above firm.

Yours faithfully,

(Name)

For and on behalf of M/s (Name of manufacturers)

8.15. Form 14: Obligation/ Compliance to be ensured by Contractor

Sl. No.	Items	Compliance of Contractor (To be filled by contractor)	
		Yes	No
1	License for employing contract labour		
2	Compliance of minimum wages Act by payment of wage on 7th of every month through Bank or in the presence of nominated representative of employer (NMRC Supervisor/manager)		
3 (a)	Compliance of provision of ESI & EPF Act		
3 (b)	Ensure treatment in ESI hospital in case of accident/injuries suffered in performance of work and compensation under ESI Act.		
4	Send Accident report to Regional Labour Commissioner (RLC) & ESI authorities.		
5	Observance of working hours, weekly rest and overtime payments as per minimum wages Act-1948.		

Note: - A Non-filling or “No” by contractor will lead to non-eligibility for contractor in further tendering process.

S.No.	Description	Reference Clause	Requirement
i	Latest “date for commencement” of the Works	Clause 8.1 of the GCC	Date given in NOA or Employer’s Notice to Proceed
ii	Liquidated Damages	Clause 8.5 of the GCC	(i) 0.015% of contract price per day of delay in completion of whole work. (ii) Total maximum limit of LD including sums payable by the employer to designated contractors is 15% as mentioned in GCC.
iii	Insurance for workers/ employees	Clause 15.4 of the GCC	All the contractor’s employees shall have to be covered under ESI and ECA as per Special conditions of contract.
iv	Insurance cover for Contractor’s all Risk and other requirements as specified in the GCC	Clause 15 of the GCC	100% of the Total Contract Price.
v	Amount of Third-Party Insurance	Clause 15.3 of the GCC	INR 0.75 Million for any one incident, with no. of incidents unlimited.
vi	Period in which all insurances have to be effected	Clause 15.5 of the GCC	Within 1 week from the “date of commencement”

Signature of authorized signatory of Tenderer

8.16. Form 15: Bid Details

The following list is intended to help the tenderers in submitting offer which are complete. An incomplete offer is liable to be rejected. Tenderers are advised to go through the list carefully and take necessary action.

S.No.	Particulars	Attached Yes / No / Not Applicable	Page no. (Mandatory)
1	Bid Processing Fees		
2	Earnest Money Deposit		
3	Form 1: Letter of Proposal Submission		
4	Form 2: Firm Details		
5	Form 3: Capability Statement		
6	Form 4: Work Experience		
7	Form 5: Financial Capability Details		
8	Form 6: Memorandum		
9	Form 7: Undertaking		
10	Form 8: Power of Attorney		
11	Form 9: Saleable Form for Tender Document		
12	Form 10: Undertaking pertaining to Personnel		
13	Form 11: Declaration of Refund of Earnest Money		
14	Form 12: Bid Offer/BOQ		
15	Form 13: Manufacturer's Authorization Form		
16	Form 14: Obligation/ Compliance to be ensured by contractor		
17	Form 15: Bid Details		
18	Statutory proof of existence as the legal entity		
19	A copy of the Annual Reports (Profit and Loss Account and Balance Sheet) for the last 3 (three) Financial Years of Bidder		
20	A self-attested copy of current valid ITR		
21	A self-attested copy of PAN, GST registration		
22	Self-attested drawings of racks in compliance to technical specifications as mentioned in RFP document		
23	Valid BIFMA Level 3 Certification, ISO 2001, ISO 45001 and EN 15512 Compliance Certificates		
24	Any other document asked by the Purchaser if submitted, specify the documents Or Any other document which the Tenderer considers relevant		

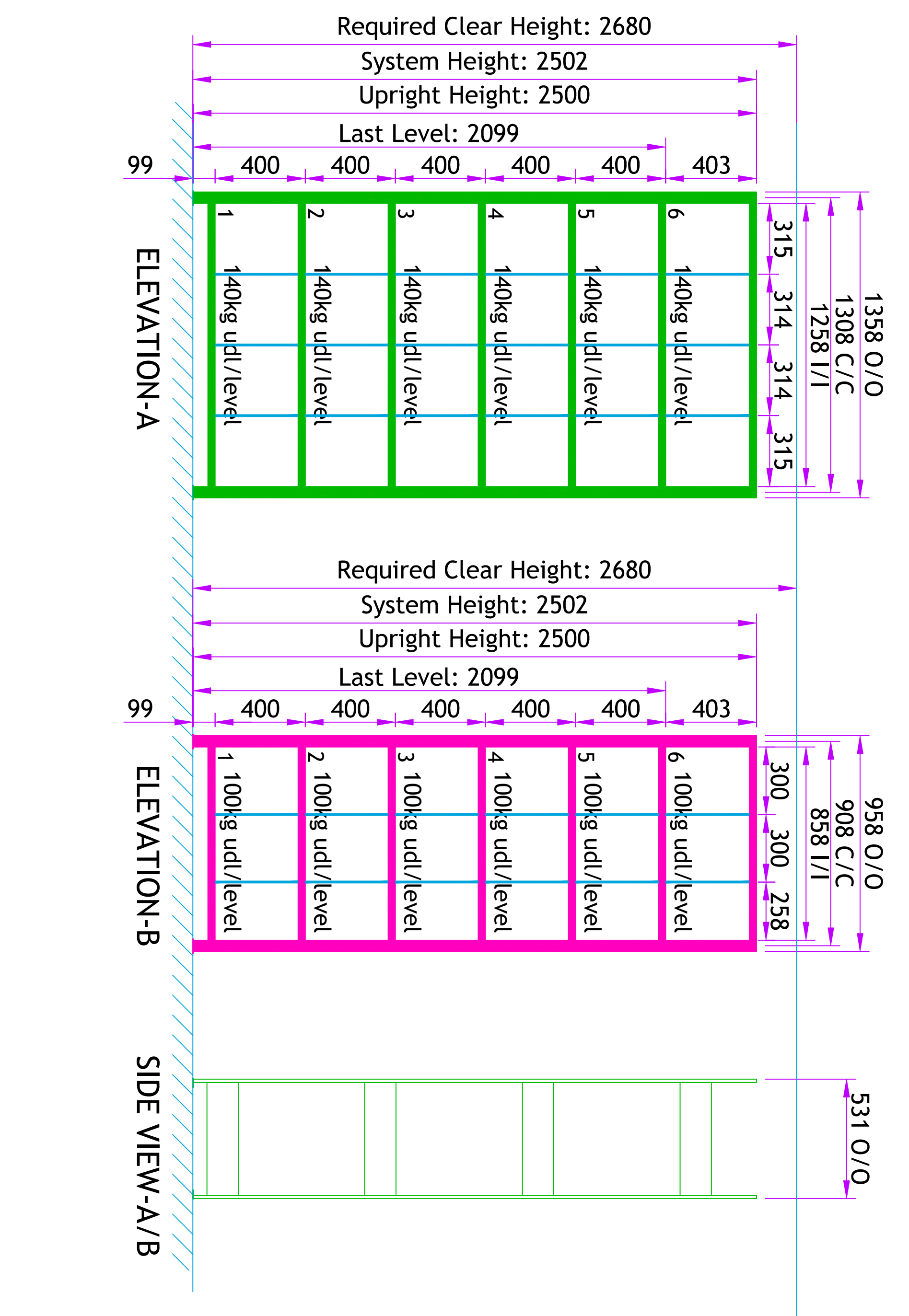
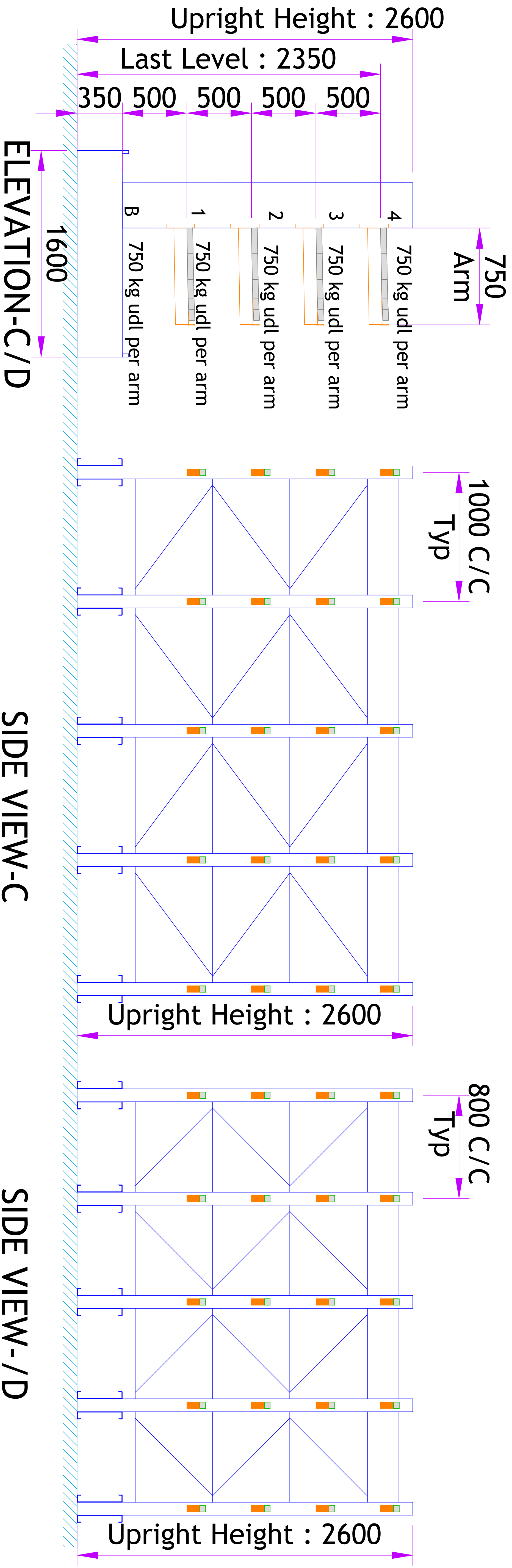
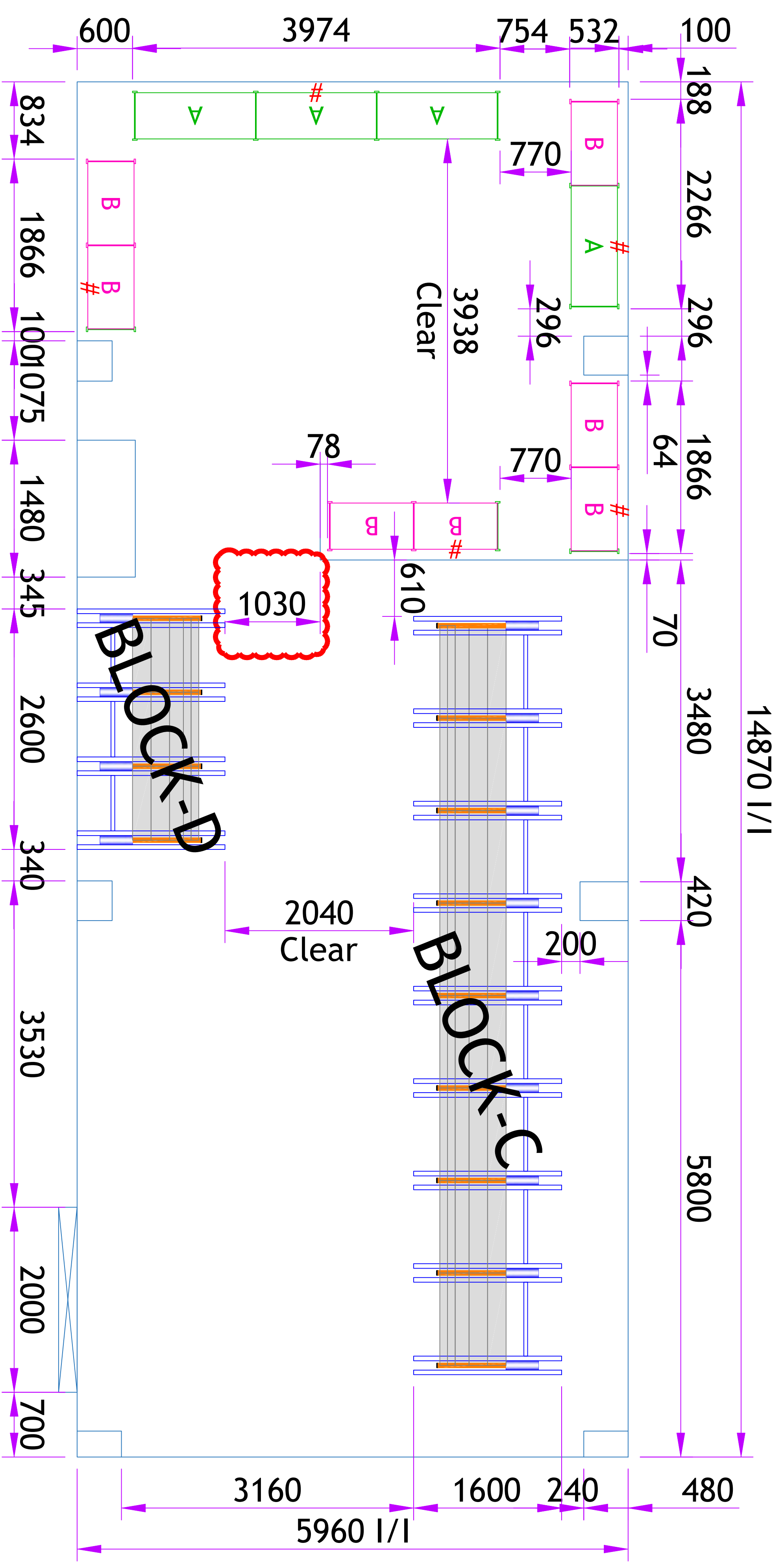

CANTILEVER DETAILS

DESCRIPTION	Block - C	Block - D
No. of Blocks	1	1
Elevation	B+4	B+4
No. of Levels	4	4
Arm Length	750	750
Load / Arm	750 Kg	750 Kg
Arm / Block	36 Nos	16 Nos

DESIGN CONSIDERATIONS

NON SEISMIC DESIGN

Load on base plate 1500kg

BASE CHANNEL OF CANTILEVER needs to be checked by customer

CAPACITY DETAILS BOLTLESS

UNIT NAME	UNIT QTY	LEVELS/ UNIT	TOTAL LEVELS
A	4	6	24
B	7	6	42
TOTAL CAPACITY			66 nos

NOTES:

1. manual movement considered.
2. Cloud mark area need to be checked.

SYSTEM CANTILEVER RACKS

CUSTOMER NOIDA METRO RAIL CO

LOCATION GREATER NOIDA

DRG. NO Annexure-1

Noida Metro Rail Co

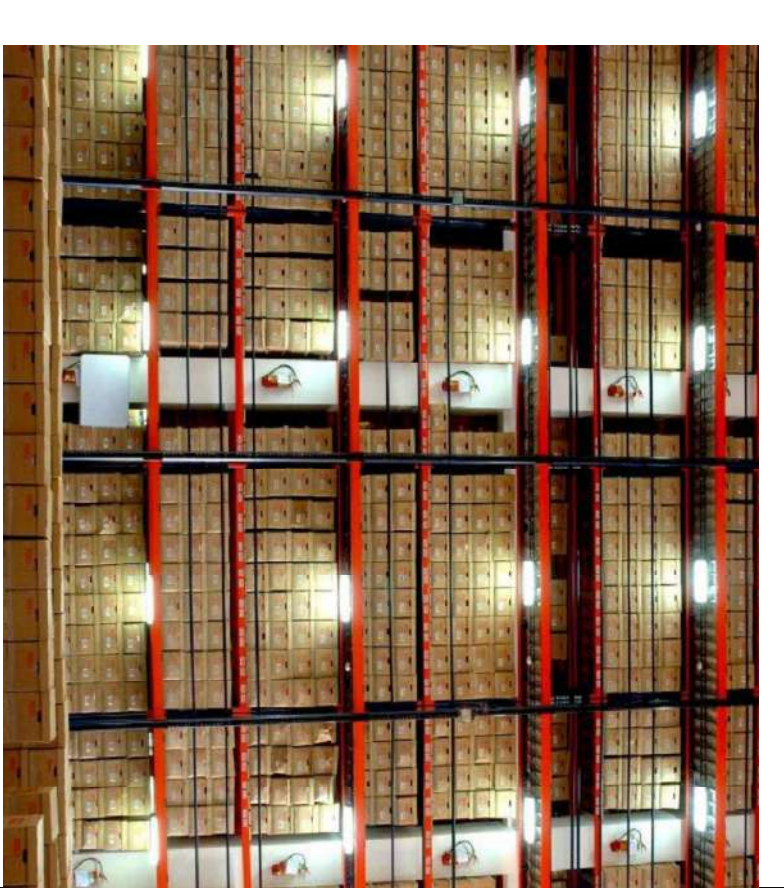

ACCESSORIES

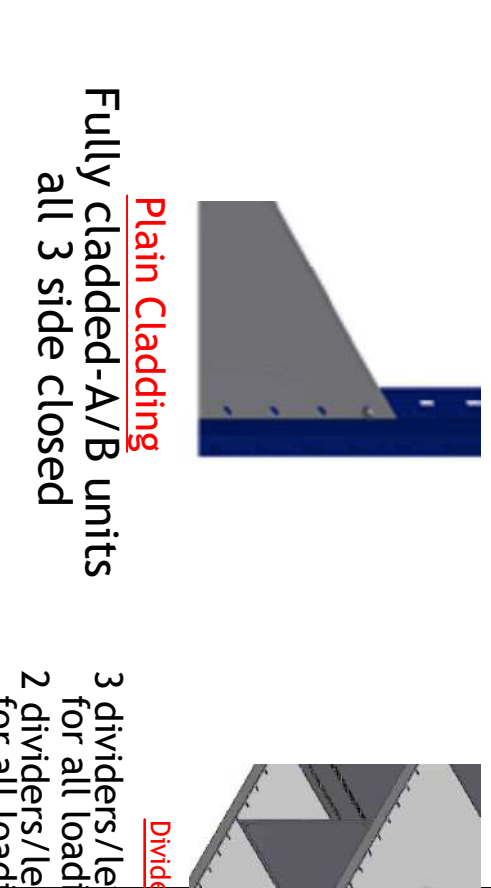

DECKING DETAILS

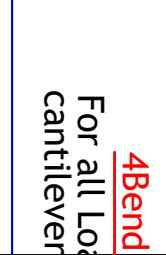
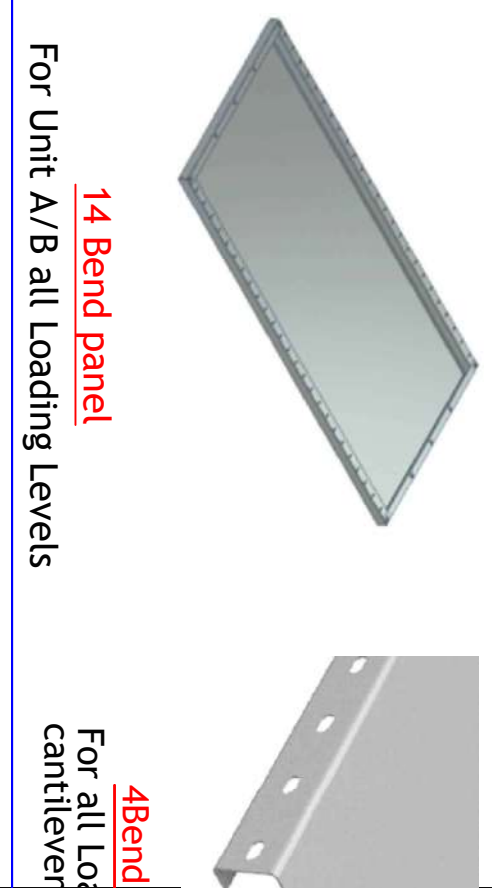

3 dividers/leg for all load for all load

Elect. and Mech. store

ANNEXURE-2

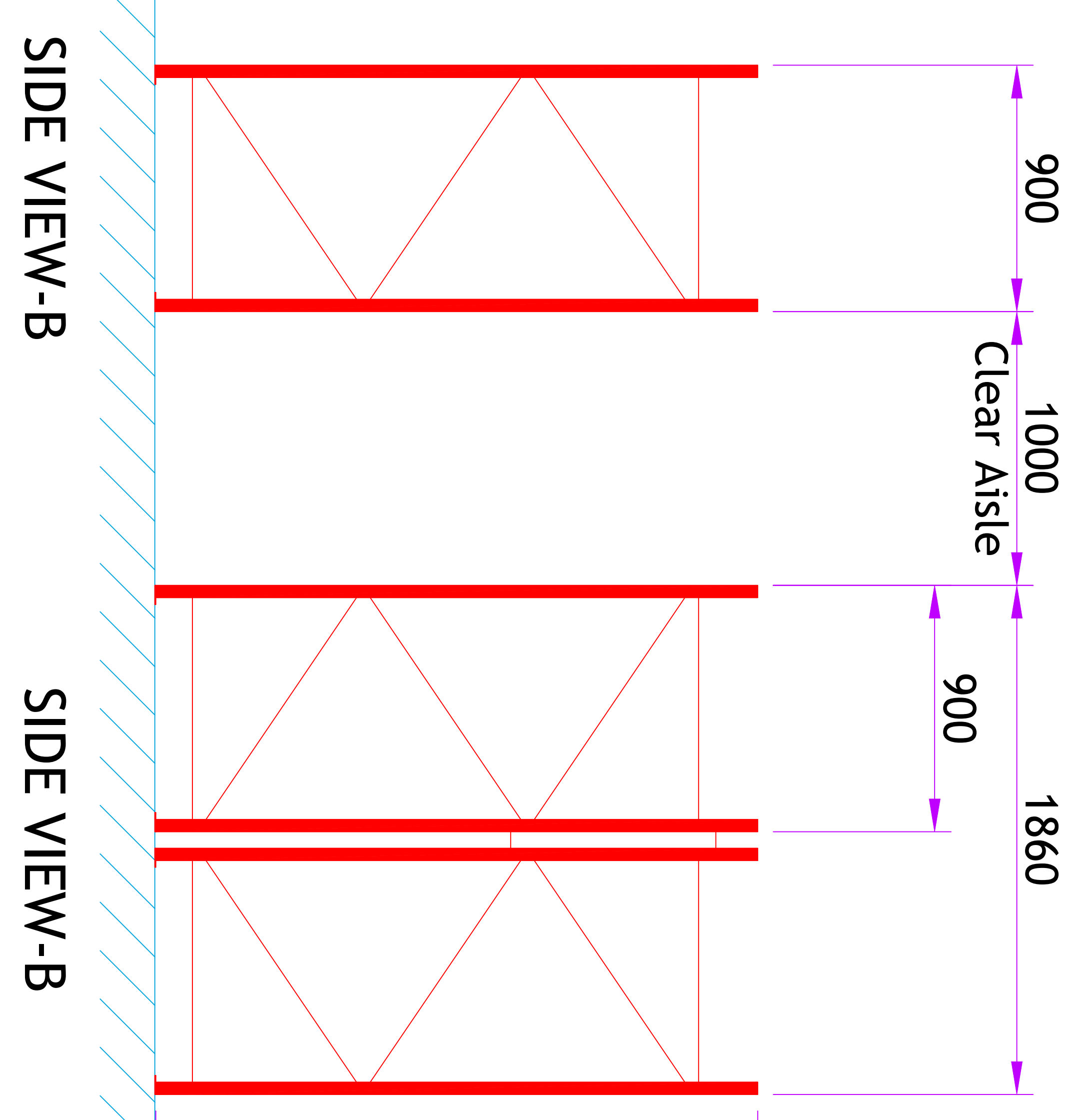
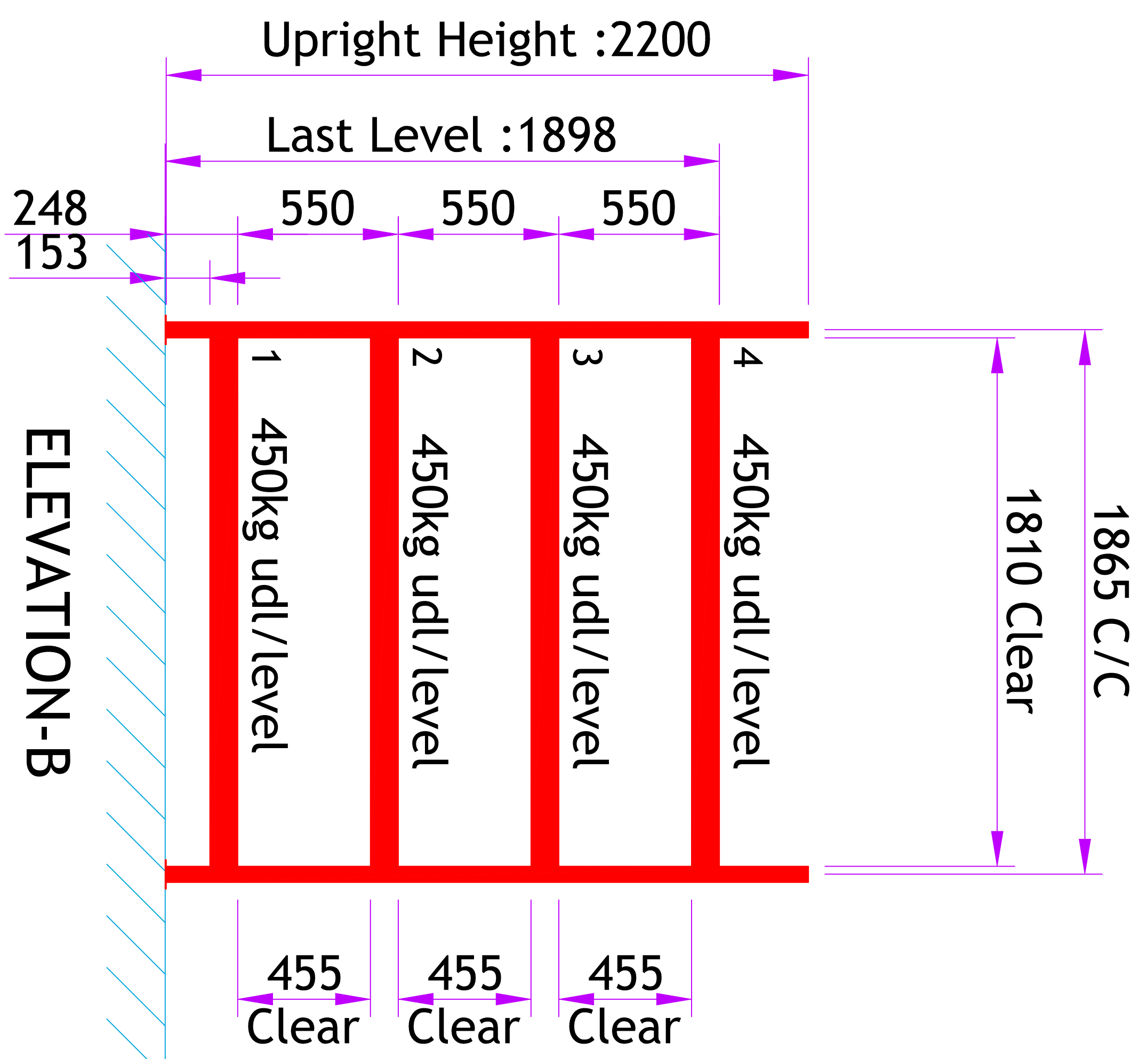
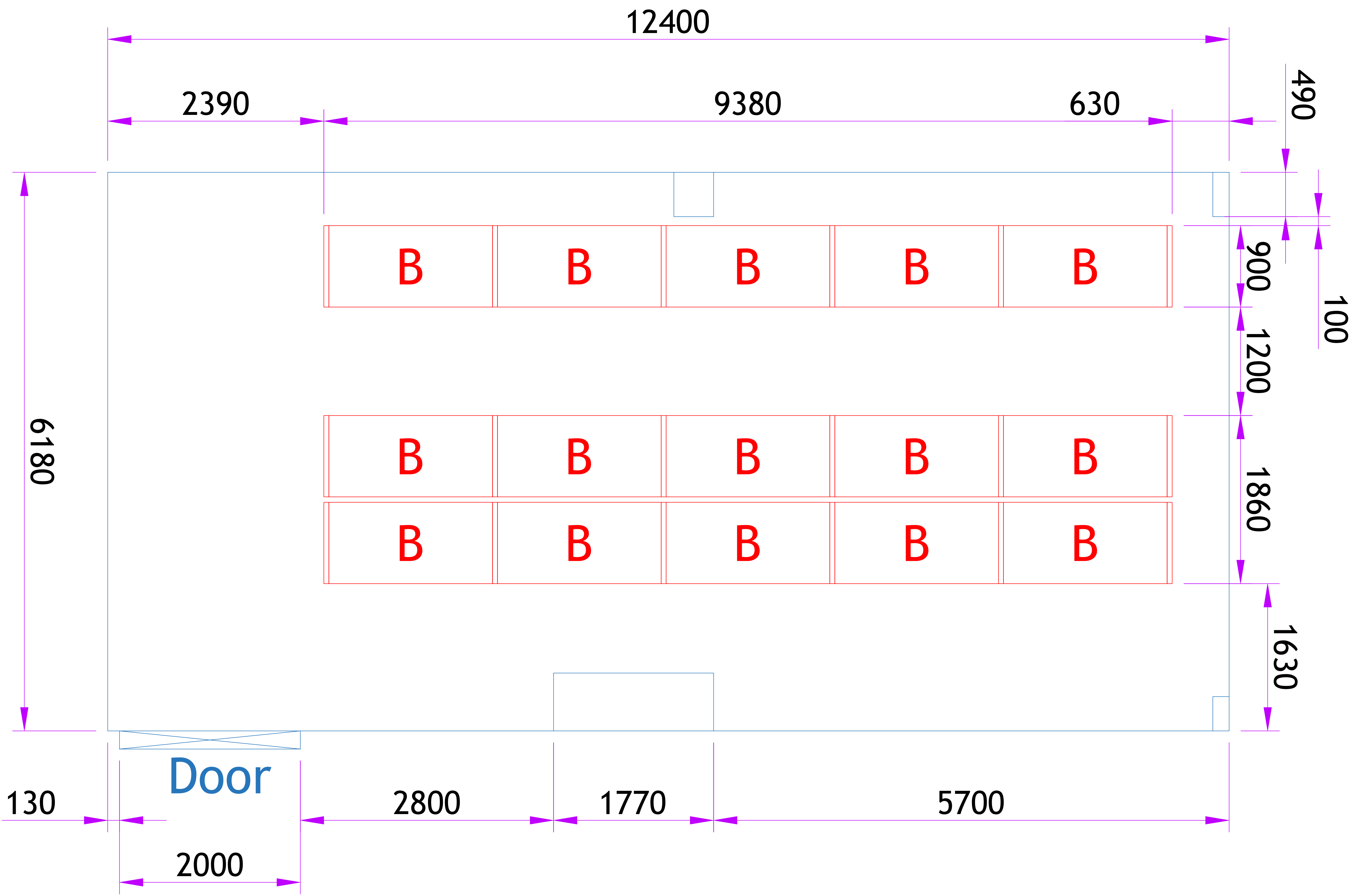

CAPACITY DETAILS			
UNIT NAME	UNIT QTY	LEVELS/ UNIT	TOTAL LEVELS
B	15	4	60
TOTAL CAPACITY			60 nos

SYSTEM	LONGSPAN SHELVING
CUSTOMER	NMRC
PROJECT SITE	NOIDA
DRG. NO	ANNEXURE-2
NOIDA METRO RAIL CO	

ANNEXURE-3

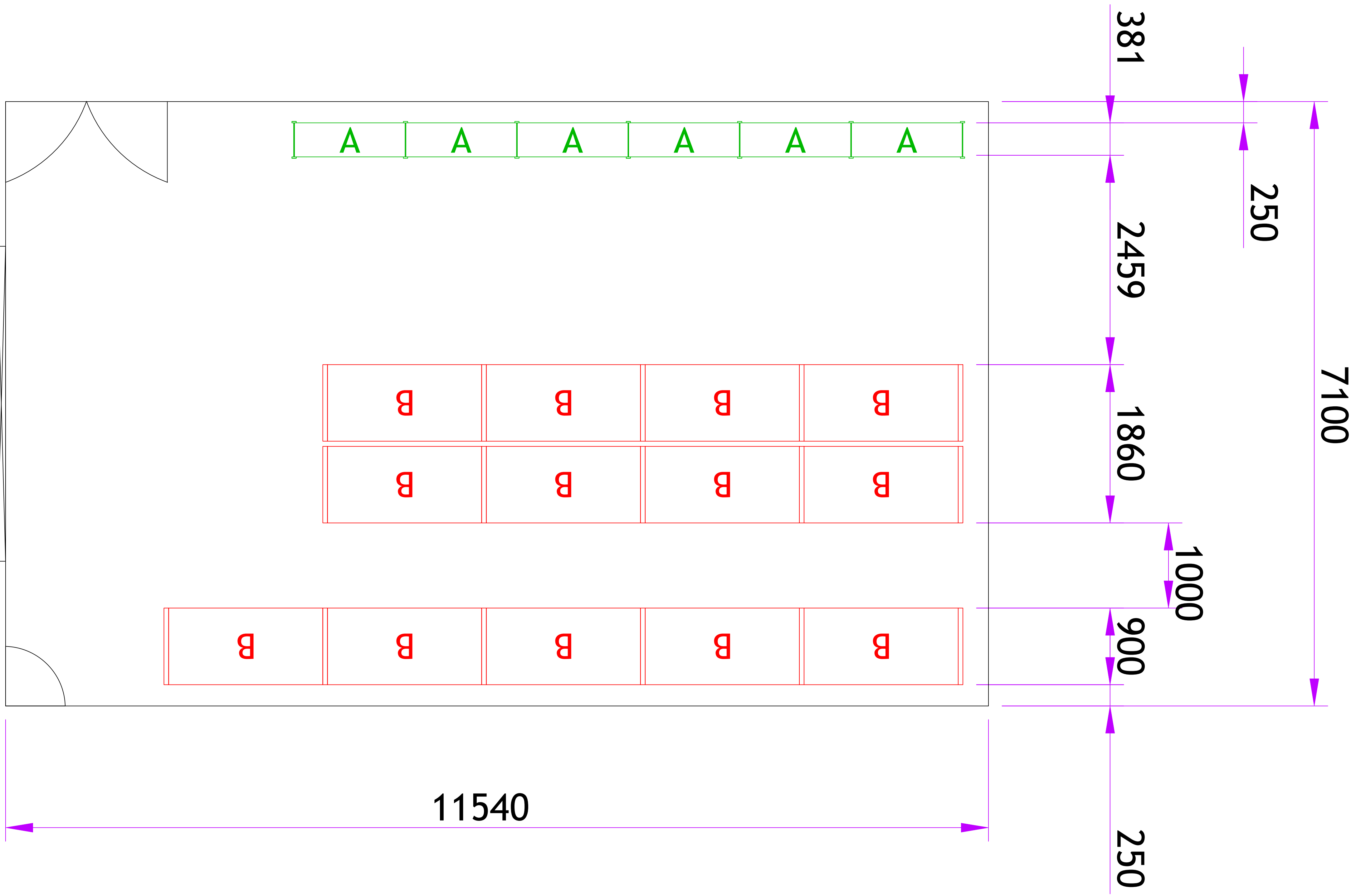

HEAVY MAINTENANCE ROOM

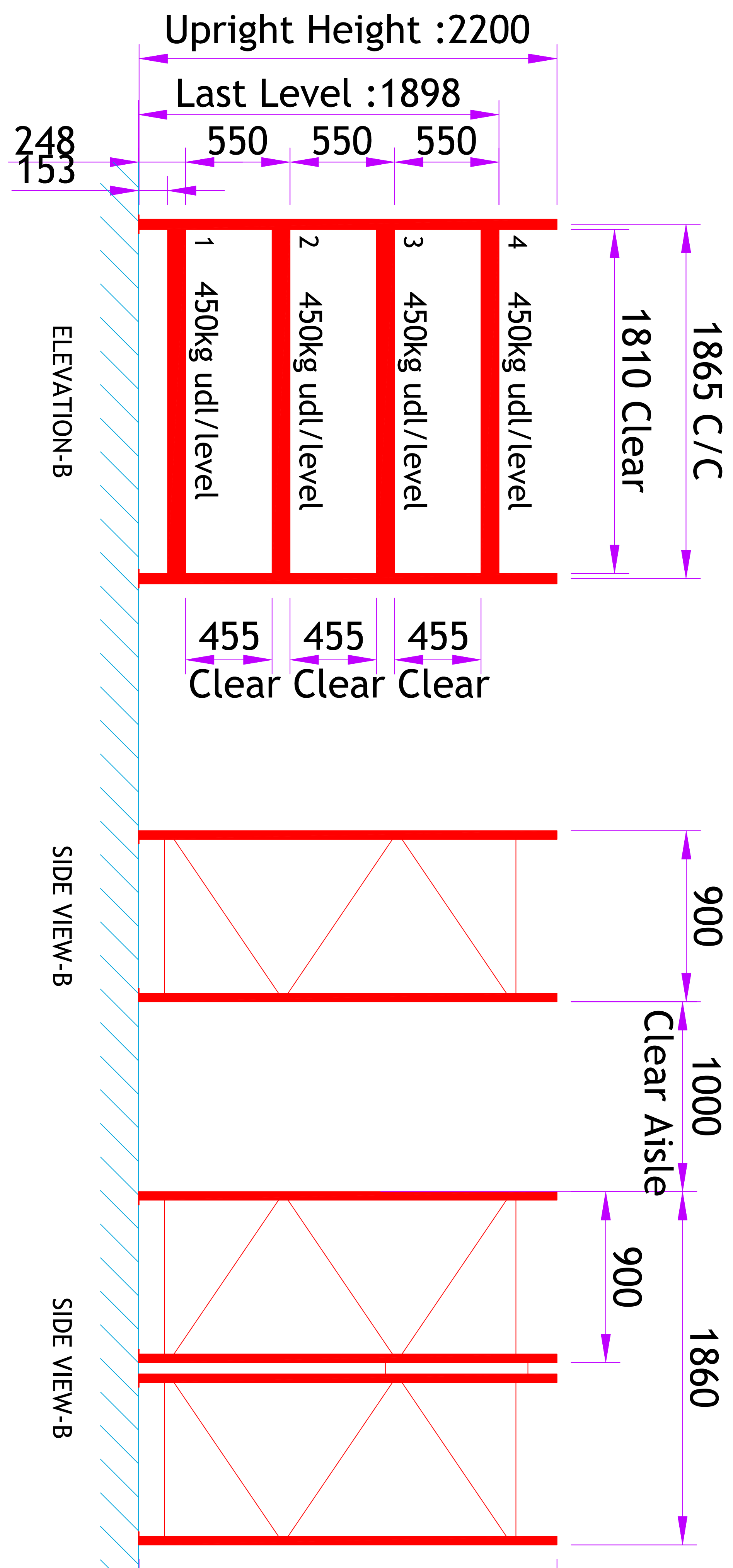
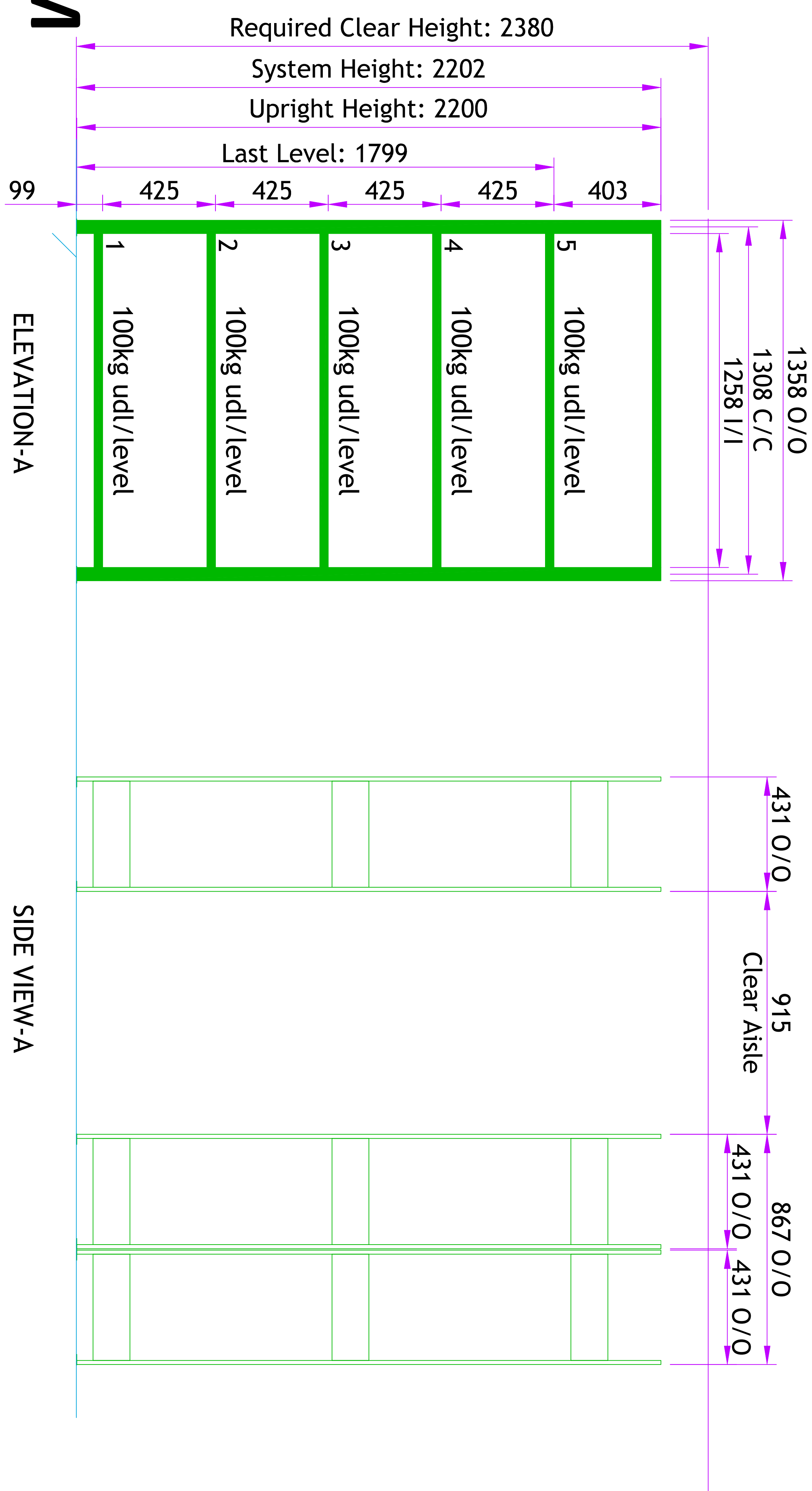

UNIT NAME	UNIT QTY	LEVELS/UNIT	TOTAL LEVELS	UNIT NAME	UNIT QTY	LEVELS/UNIT	TOTAL LEVELS
B	13	4	52	A	6	5	30

TOTAL CAPACITY	TOTAL CAPACITY
52 nos	30 nos

PSI store

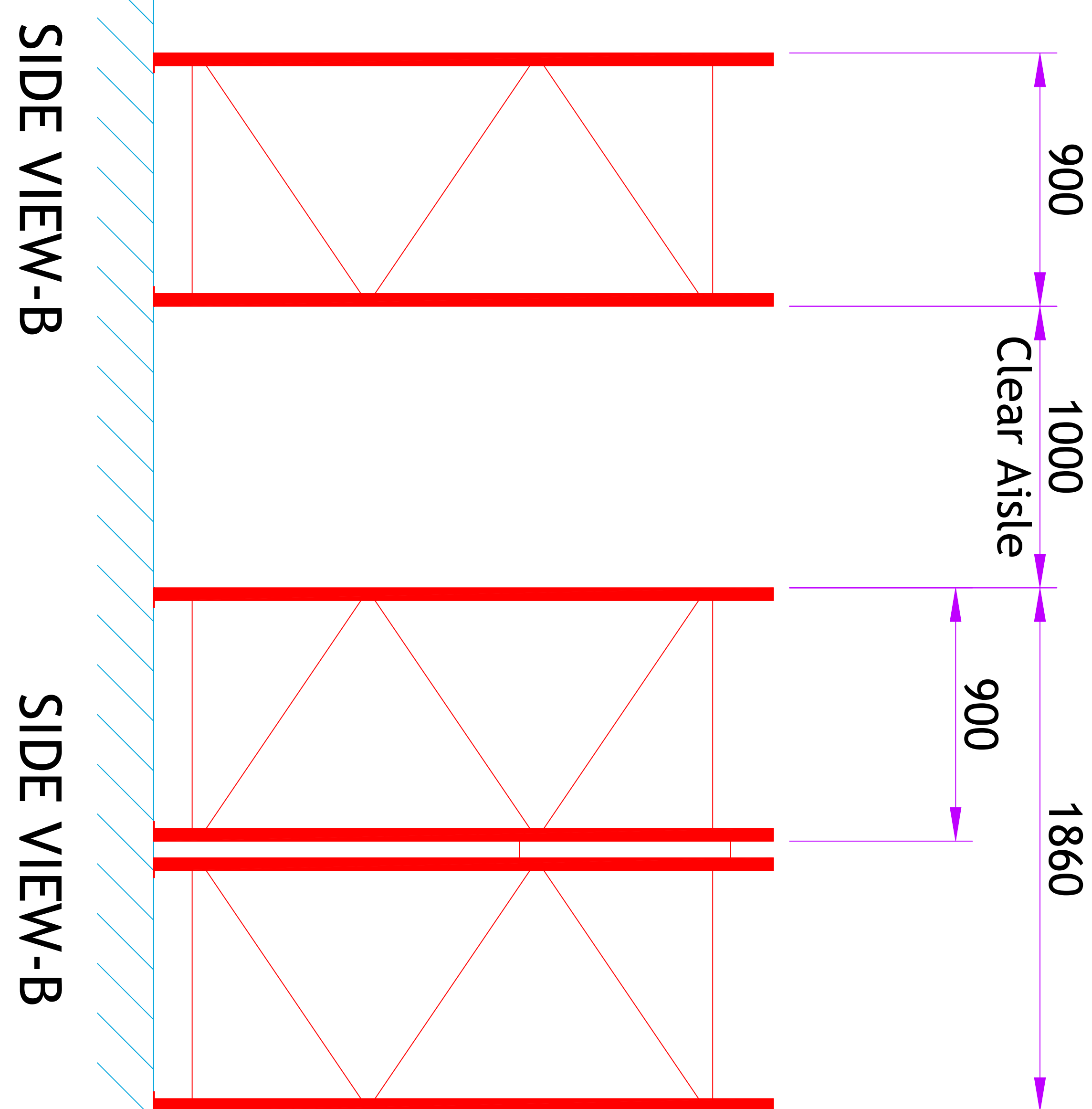
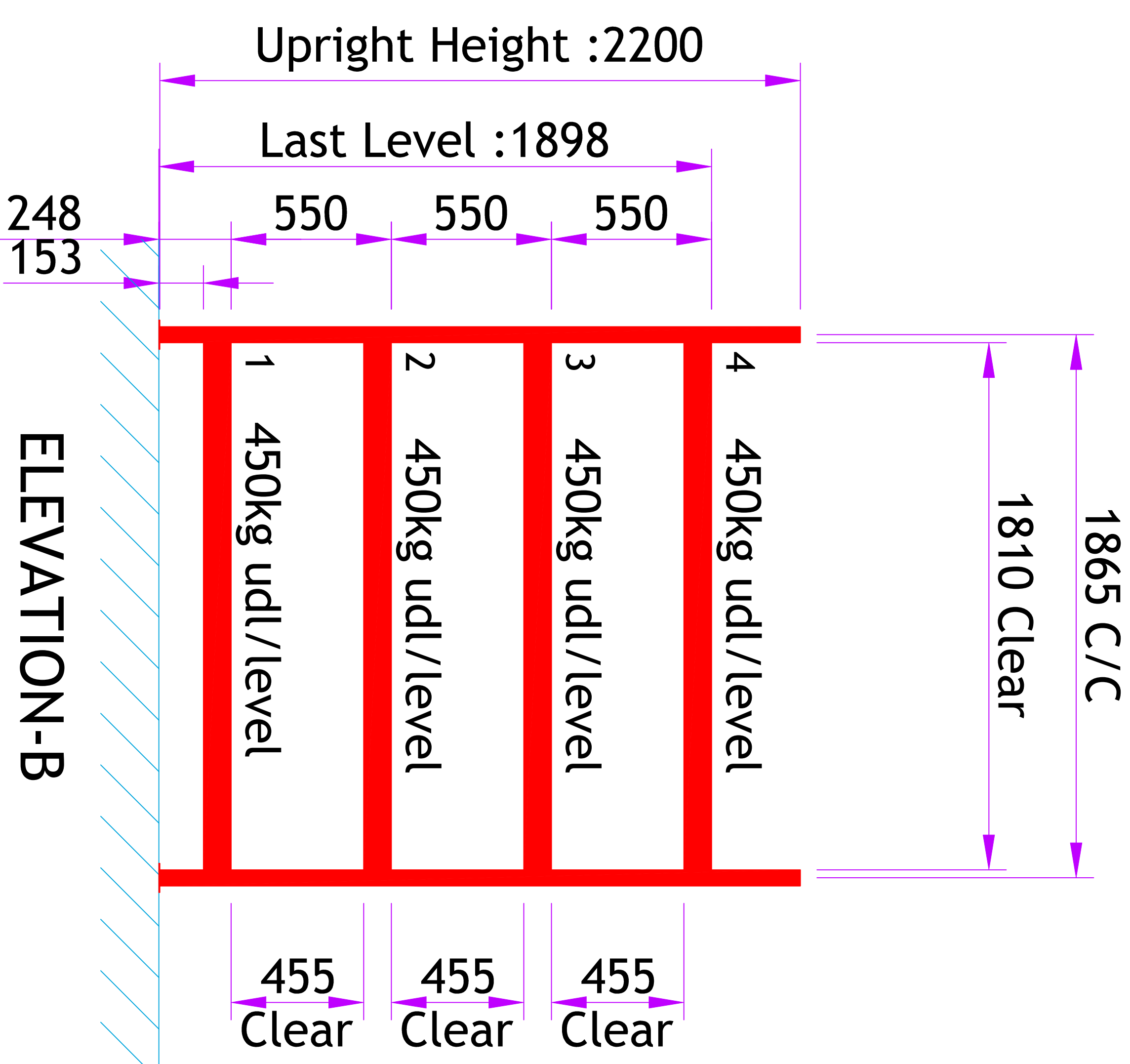
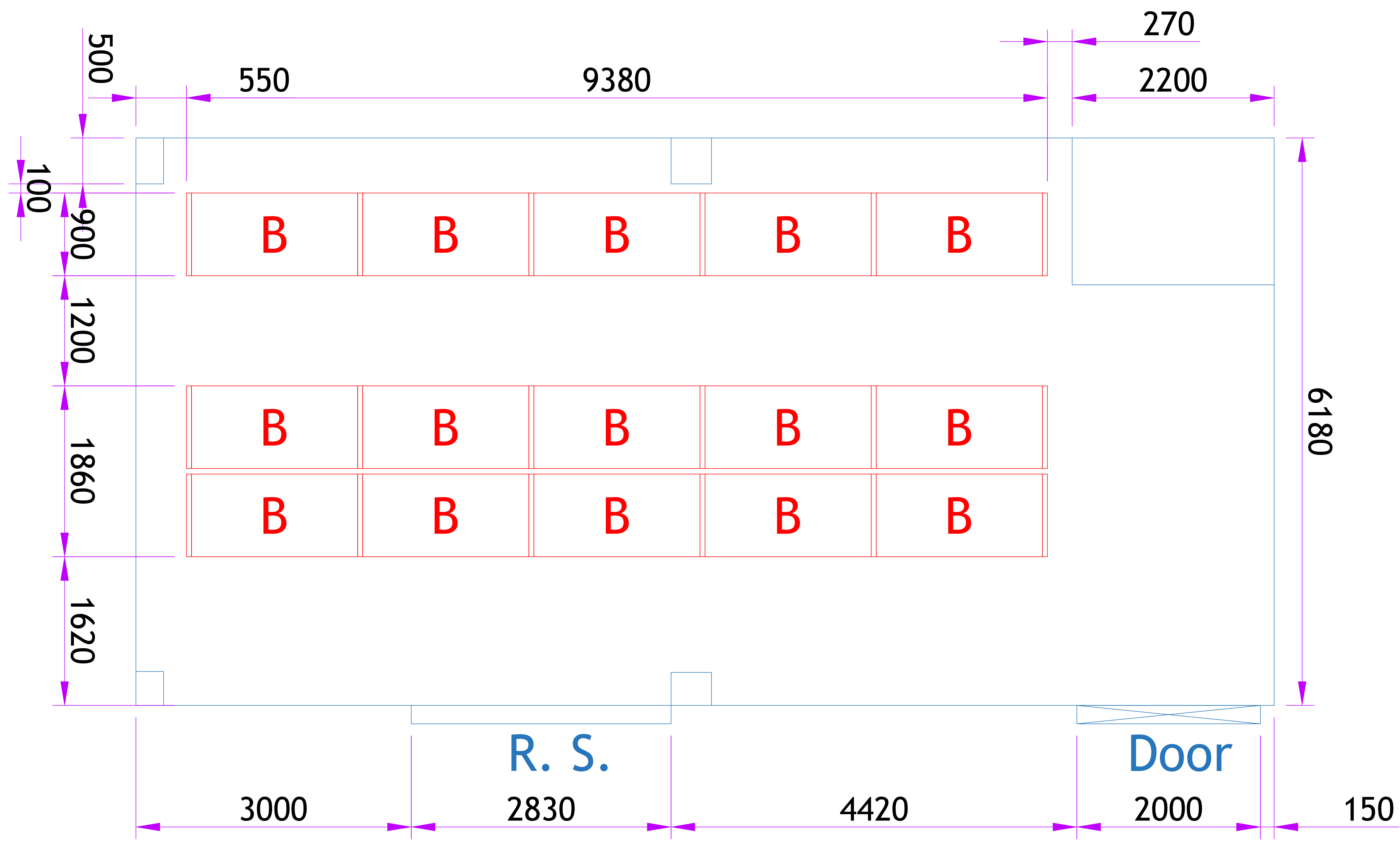

Annexure-4

CAPACITY DETAILS			
UNIT NAME	UNIT QTY	LEVELS/ UNIT	TOTAL LEVELS
B	15	4	60
TOTAL CAPACITY			60 nos

DRWN	APPD	DATE	DATE
		15 Jun 2019	15 Jun 2019
SYSTEM		SHELVING SYSTEM	
CUSTOMER		NMRC	
PROJECT SITE		NOIDA	
DRG. NO		Annexure-4	
NOIDA METRO RAIL CO			

ANNEXURE-5

NO HPT and Trolley movement considered over catwalk

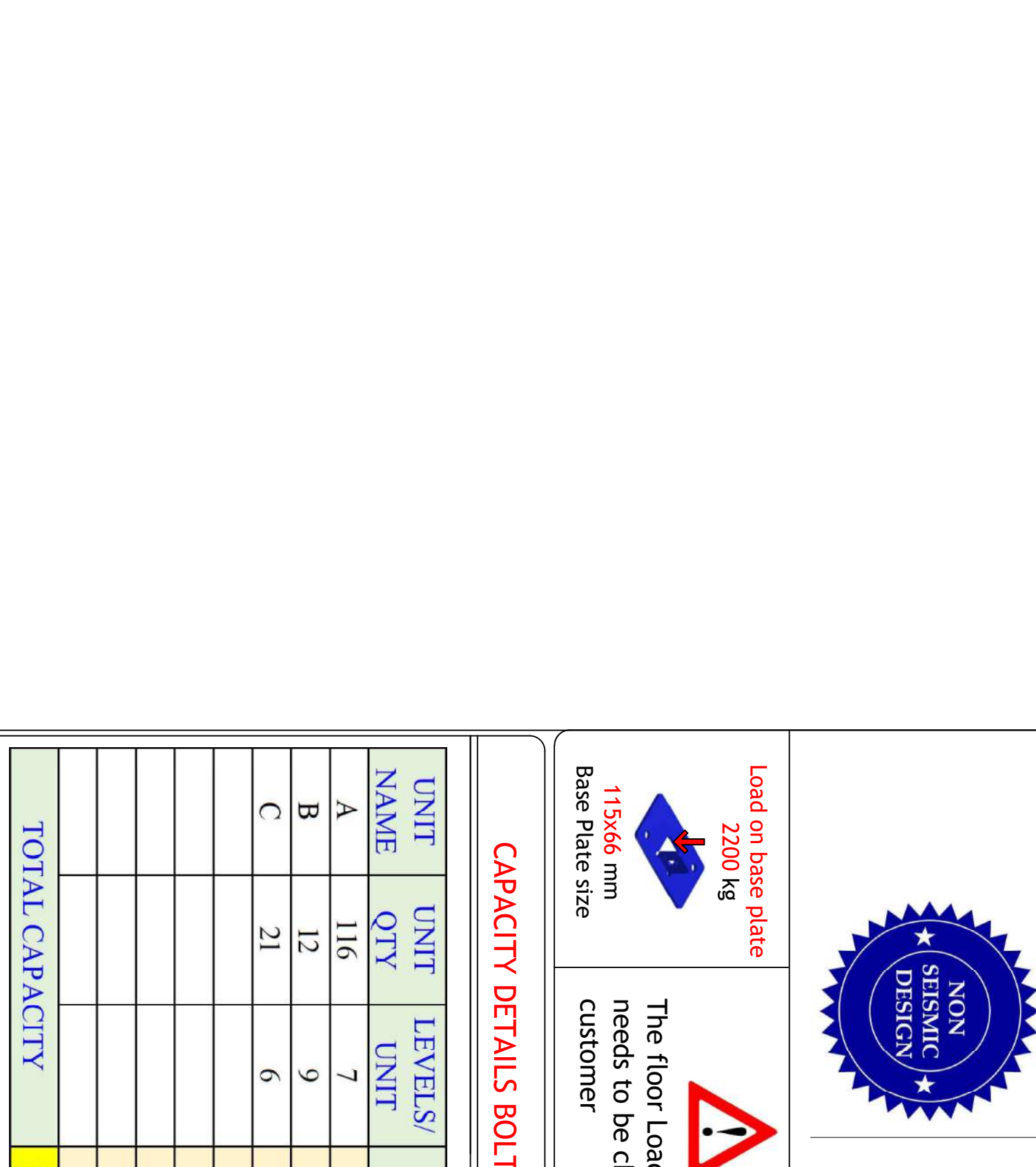
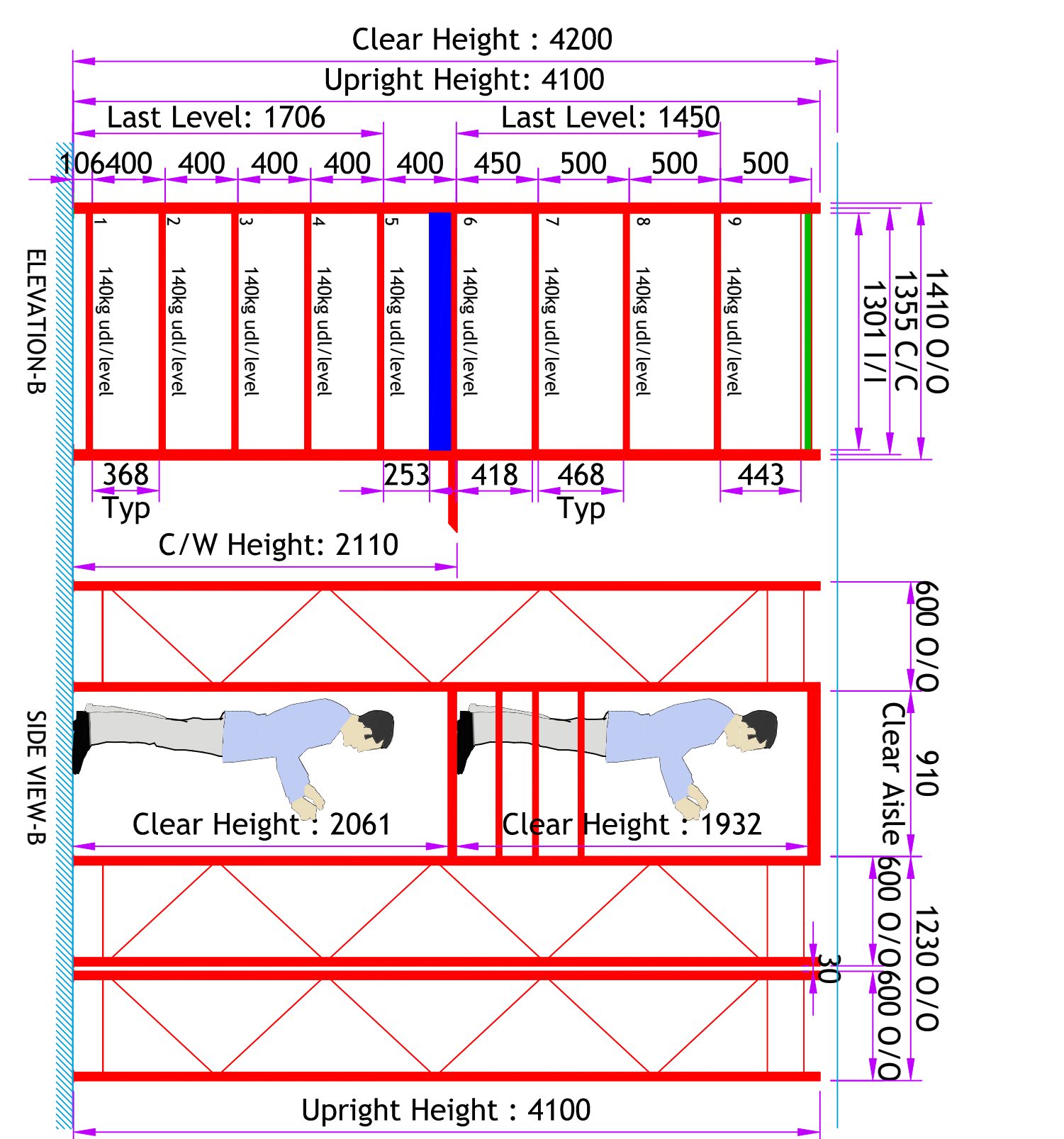
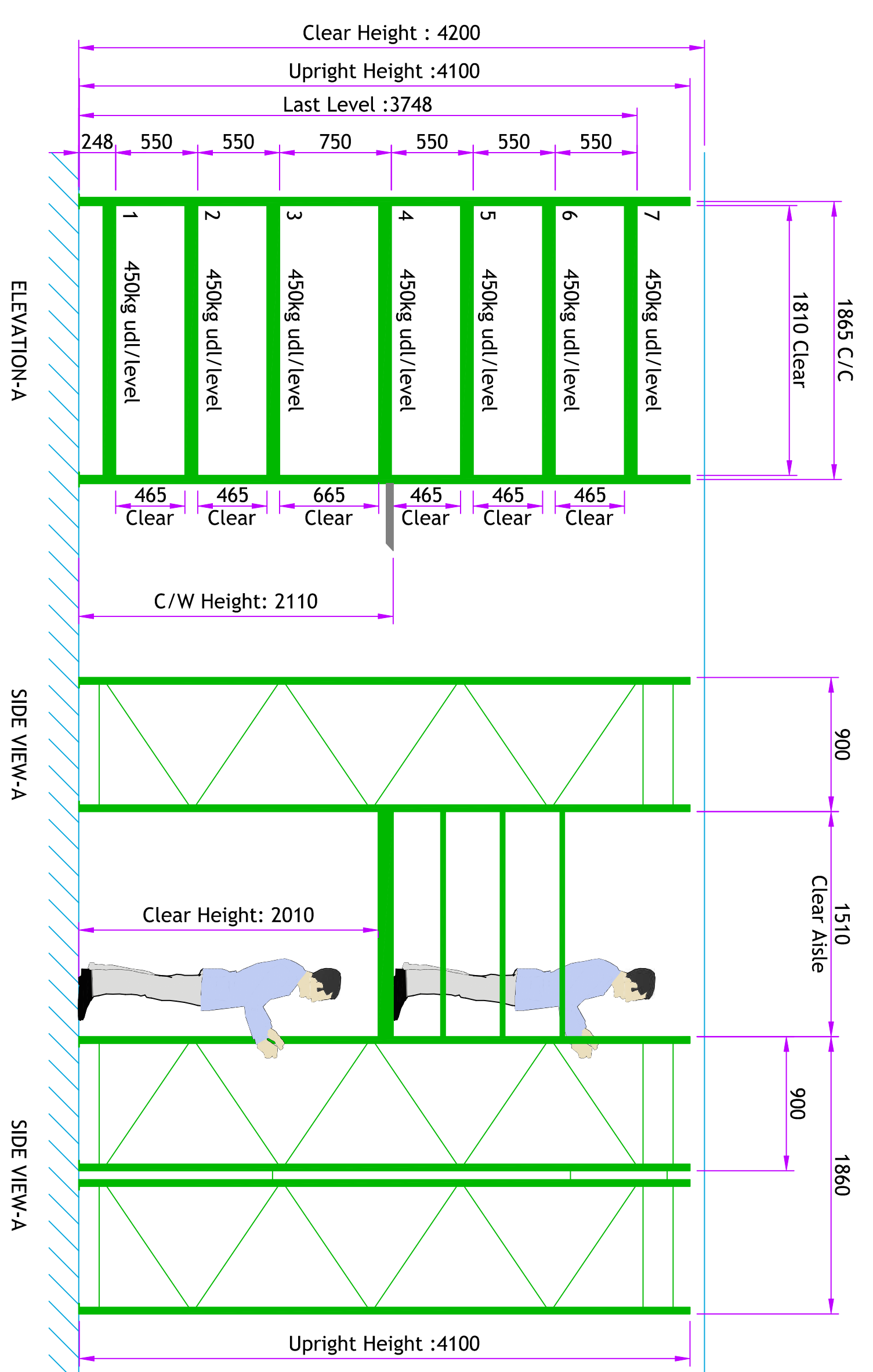
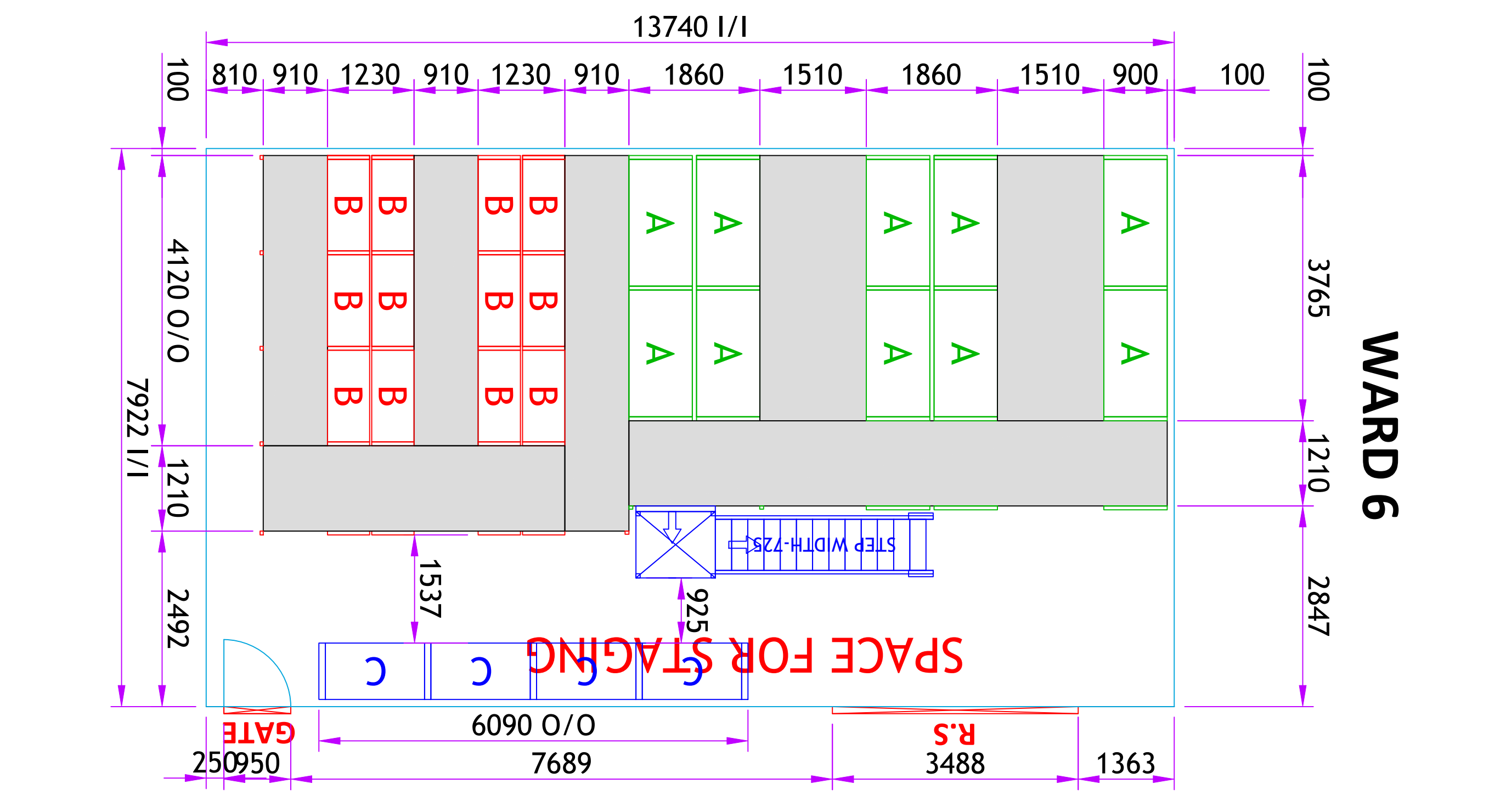
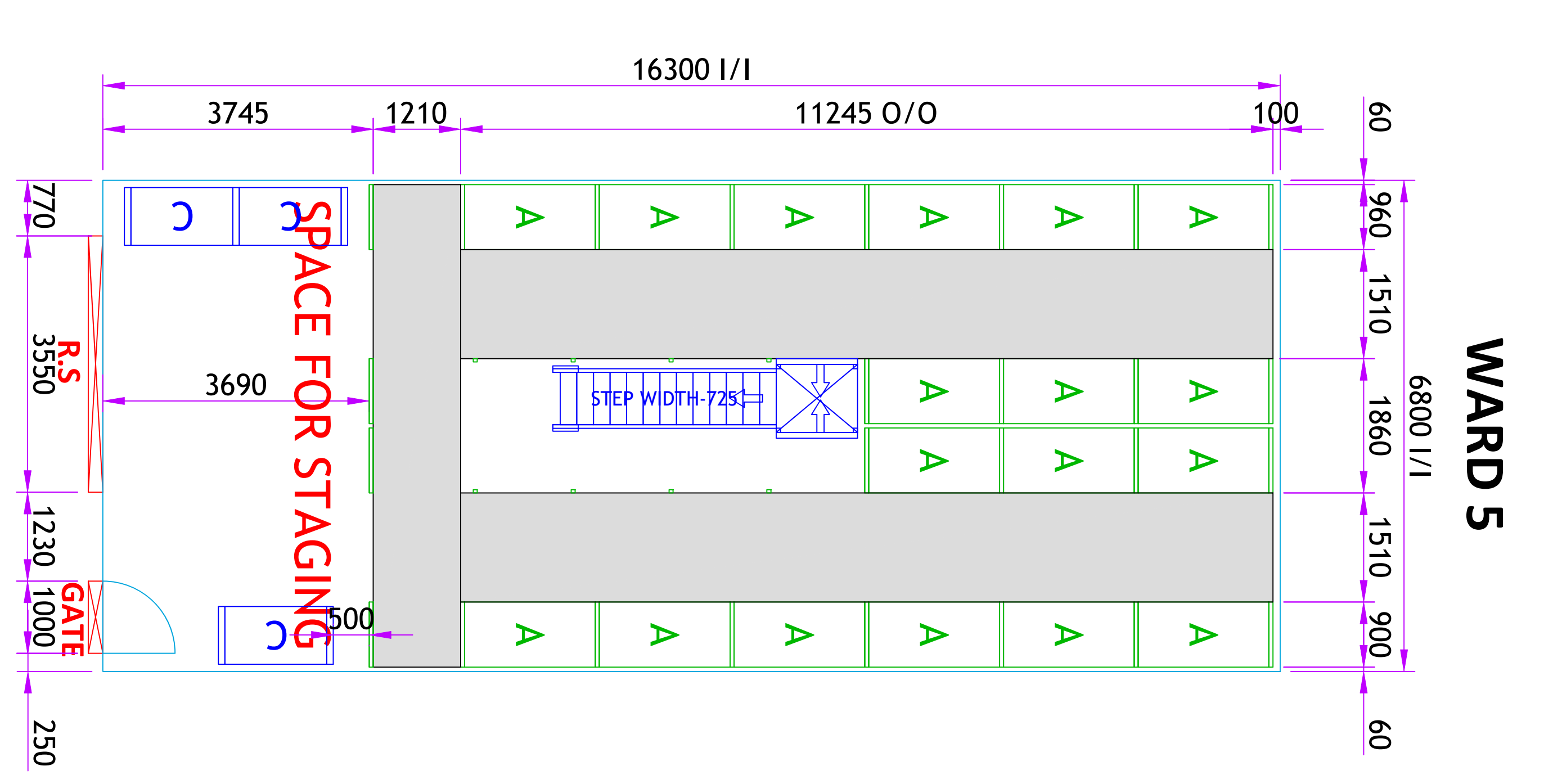
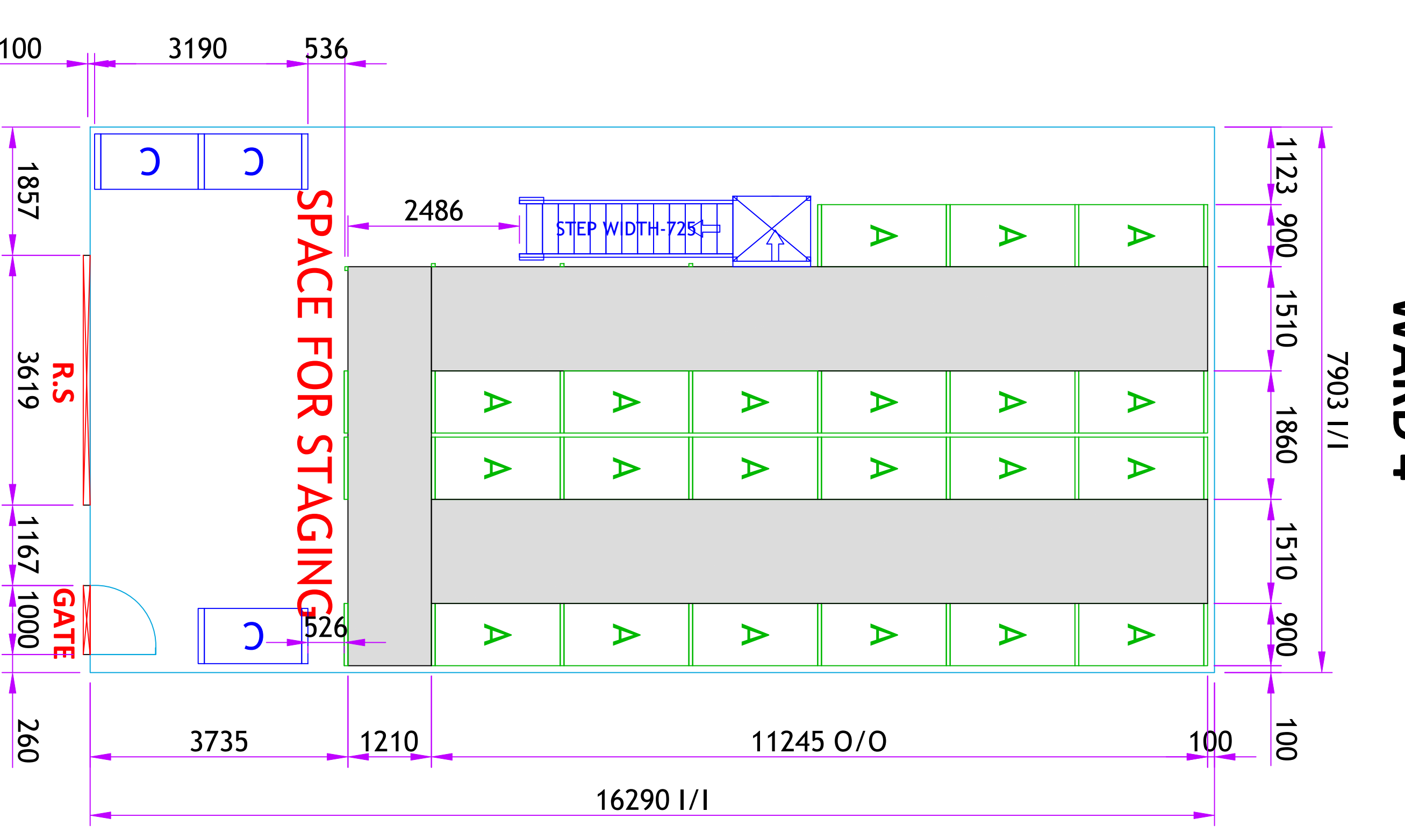
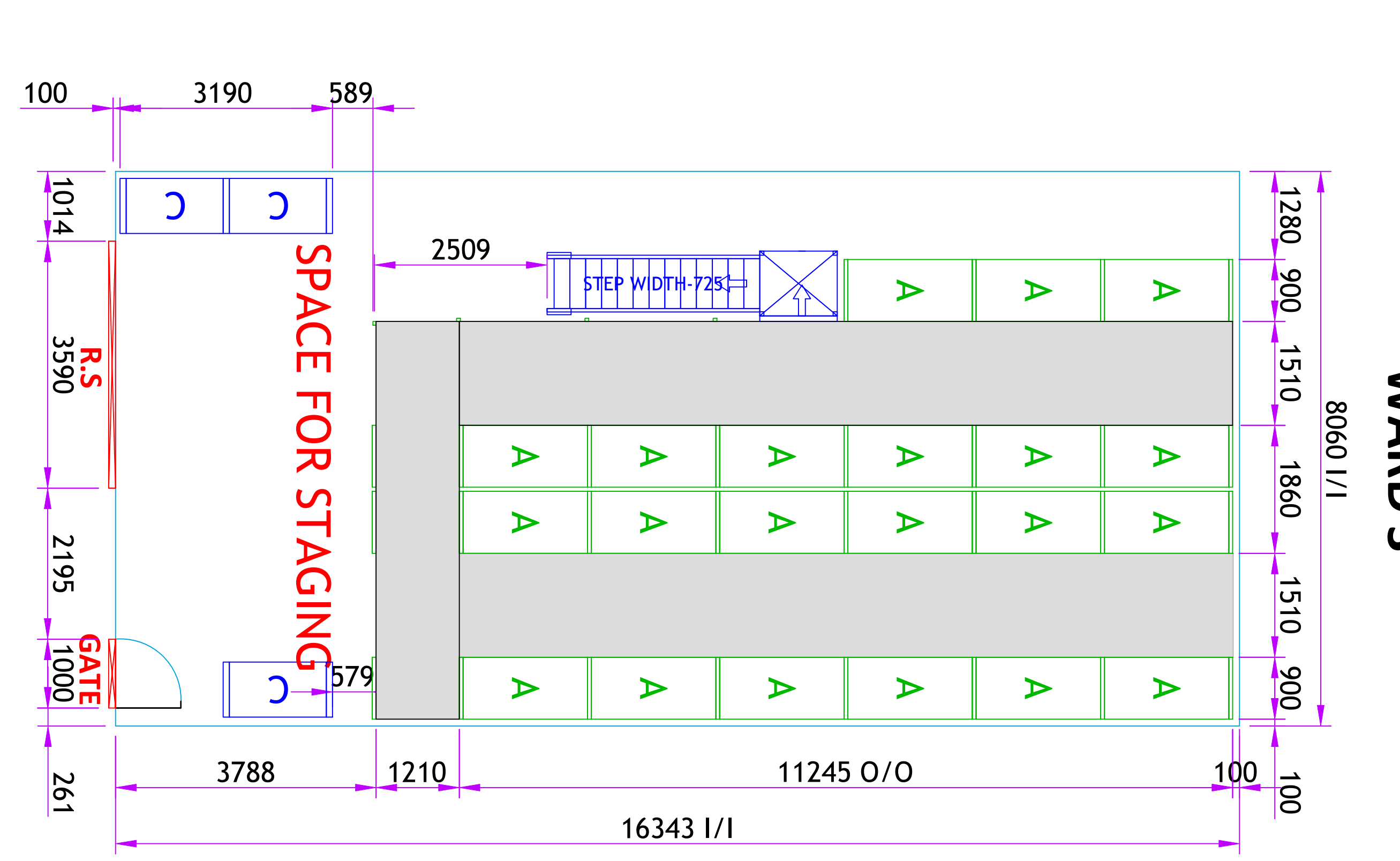
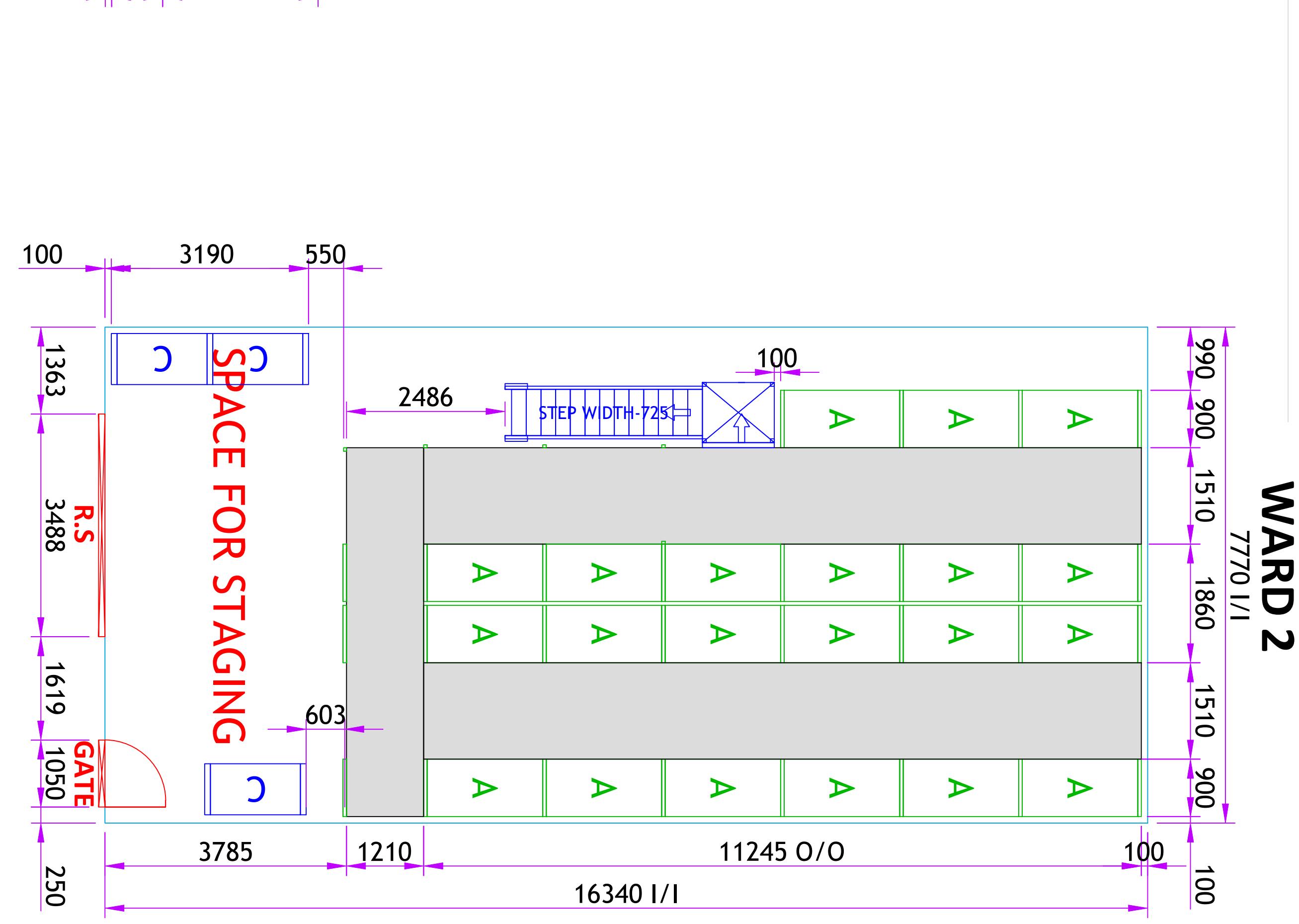
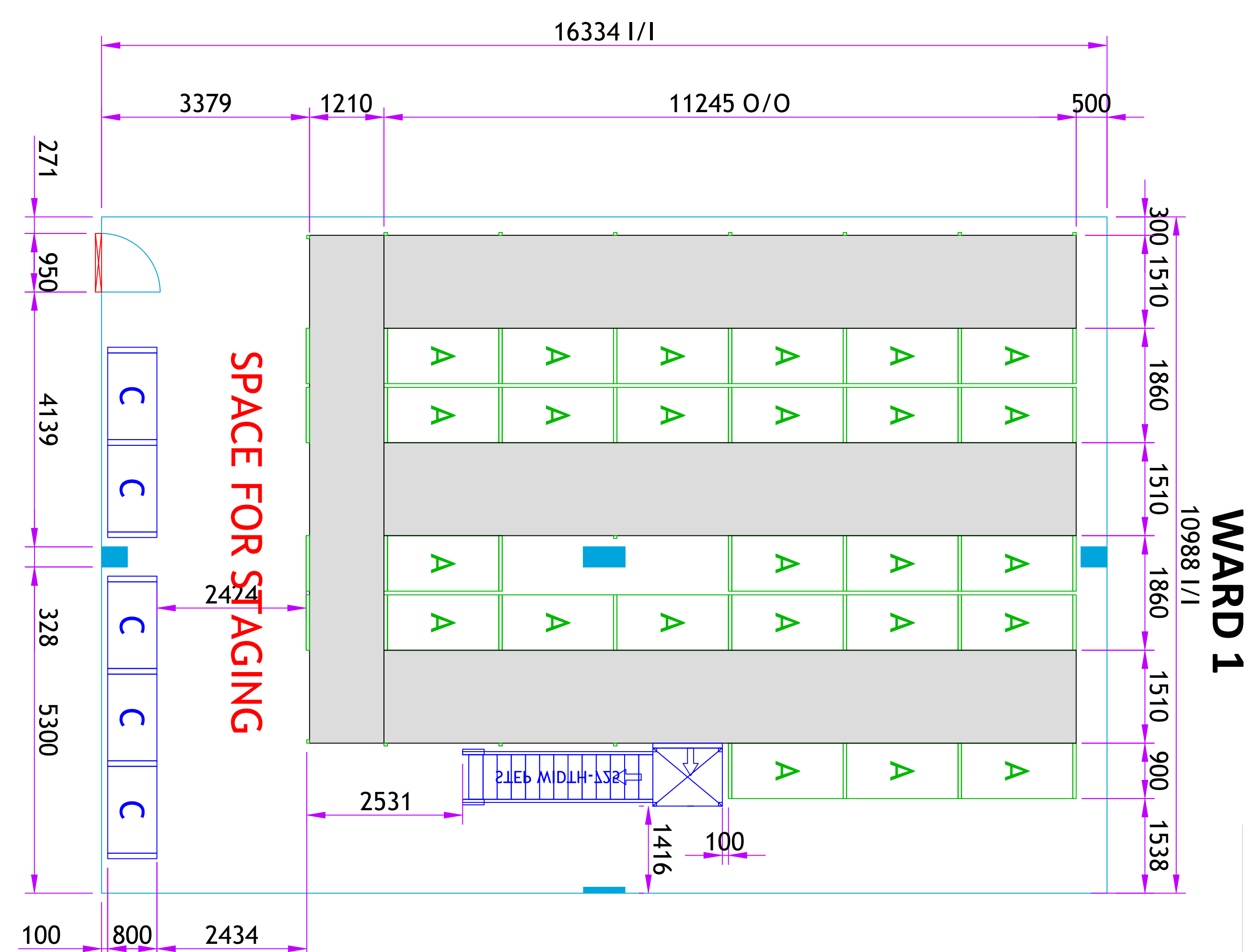

CAPACITY DETAILS BOLTLESS				
UNIT NAME	UNIT QTY	LEVELS/UNIT	TOTAL LEVELS	TOTAL CAPACITY
A	116	7	812	
B	12	9	108	
C	21	6	126	
TOTAL CAPACITY				1046 nos

DESIGN CONSIDERATIONS	
NON SEISMIC DESIGN	
DESIGN DETAILS BOLTLESS	
Load on base plate	
113x66 mm Base Plate size	
The floor Load capacity needs to be checked by customer	

Notes:
 1. HPT movement only in ground.
 2. For standalone units channel type base plate is considered.

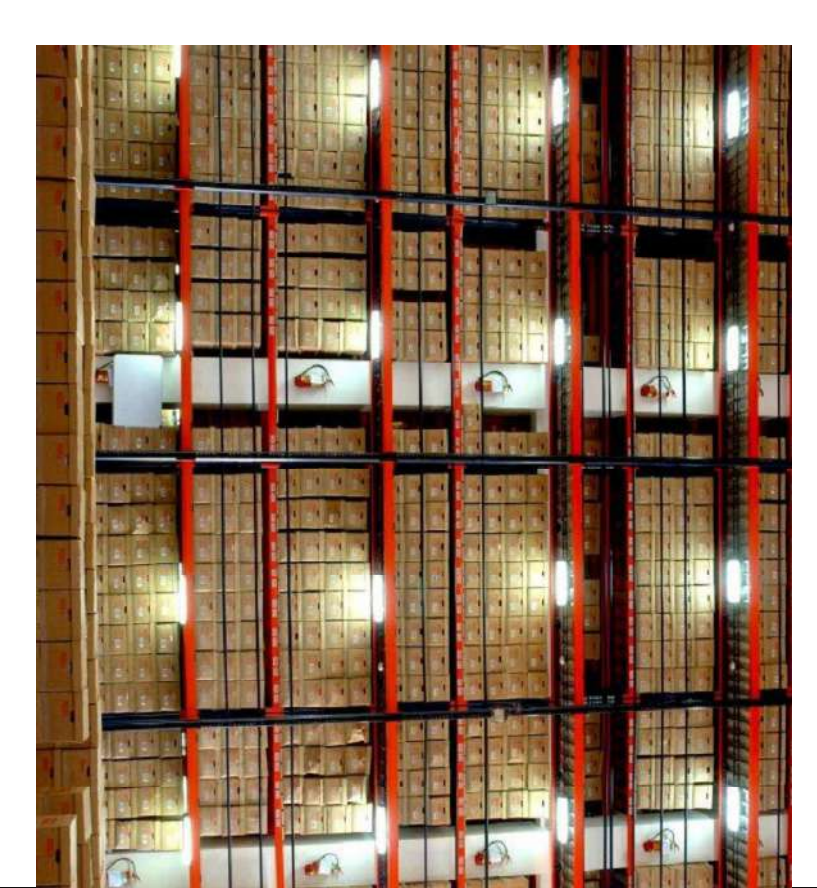

TYPICAL SHELVING

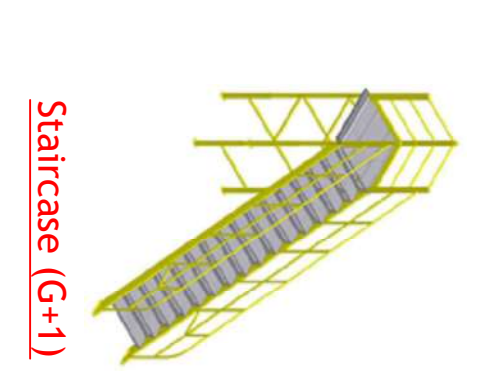

WALKWAY DETAILS

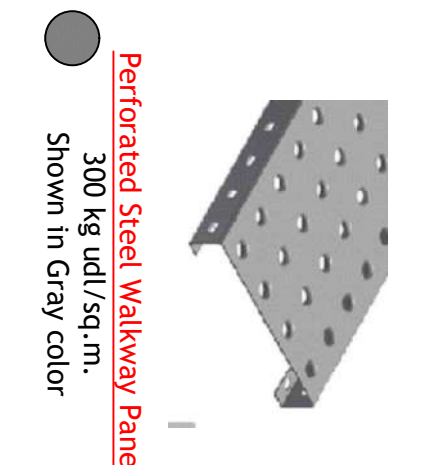

DECKING DETAILS

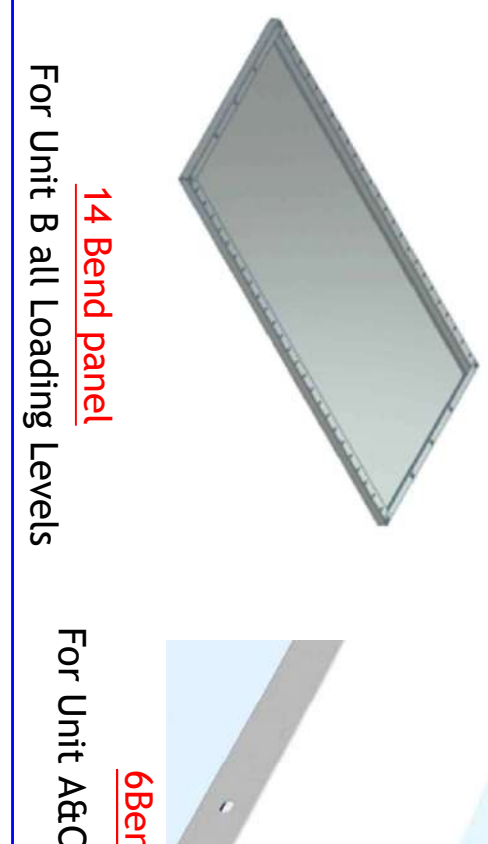

Annexure – 6 (Technical Specifications)

6.1 TECHNICAL SPECIFICATIONS:- Long span Multitier Shelving System Type-A



Design

Uses the following standards, as applicable for design.

Racking Codes:

ANSI-MH-16.1-2008	Specification for the design testing & utilization of industrial steel storage racks (American)
BS EN 15512:2009	Steel static storage systems - Adjustable pallet racking systems – Principles for structural design (European)
SEMA	Code of practice for the Design of Adjustable Pallet Racking (British)

Structural Design Codes:

IS 801 - 1975	Code of Practice for use of Cold-formed Light Gauge steel structural members in General Building Construction
IS 800 – 2007	General Construction in Steel - Code of Practice
BS 5950 – Part V	Structural use of steelwork in building - Part 5 - Code of Practice for design of cold-formed thin gauge sections (British)
EN 1993-1- Part 3	Design of steel structures. General rules. Supplementary rules for cold-formed members and sheeting (European)
AISI -1996	Cold Formed Steel Design Manual – American Iron and Steel Institute (American)

Tolerances:

BS EN 15620 - 2008	Steel static storage systems - Adjustable pallet racking – Tolerances, Deformations and clearances (European)
SEMA	Guideline No 2 - Guide to Erection Tolerances for Static Racking (British)

Raw material

Load bearing members of the system are made out of high strength HR steel having properties

equivalent to grades specified by IS 5986:2002 / IS 2062:2006

The different types of material used for load bearing members such as uprights and beams are:

Steel type	Minimum guaranteed yield strength	Equivalent international standard
IS: 5986 – ISH430LA / Equivalent (or) IS:2062 - E 350 / Equivalent	355 MPa	JIS 3101: SS 490 EN 10025 : S 355 JR DIN 17100 : St 52
IS: 5986 – ISH410S / Equivalent (or) IS:2062 - E 250 / Equivalent	255 MPa	JIS 3101: SS 400 EN 10025 : S 235 JR DIN 17100 : St 42
IS:3601 – 2006 / Equivalent IS:4923 – 1997 / Equivalent	210 Mpa	
IS :513 – 2008 / Equivalent	210 Mpa	JIS 3141
	355 MPa	ASTM A 653 M SS GRADE 50
	255 MPa	ASTM A 653 M SS GRADE 37
IS 277'D'	210 Mpa	

In addition to high strength, the raw material used for structural load bearing members, posses adequate ductility, to ensure toughness. The material also has the necessary impact strength for cold room applications up to -30 deg C.

Fasteners

All fasteners used are of grade 8.8. These are with galvanized finish to suit industrial atmosphere.

Surface finish

For long life and protection from corrosion, All Powder coated components are given a thorough anti-rust treatment. The dry film thickness (DFT) after powder coating would be on an average 35 microns.

All powder coated components are subjected to an elaborate 4 step, six zone anti corrosion treatment, viz. De-greasing as per IS 6005:1970, rinsing, phosphating as per IS 3618:1966 and RO water rinsing.

Furthermore, the testing of paint for various physical and chemical properties is done as per IS ASTM Standards.

Shelving component specification

Upright is roll formed construction made in single piece without welding. Upright has slots at 50 mm. It enables the warehouse manager to utilize the rack optimally to suit the changing SKU sizes.

Uprights are multi bend profiles, designed to offer maximum load bearing capacity with optimum surface utilization ensuring high standards of stability and safety. Uprights are bolted with

base plates to transfer the load to ground.

The manufacturing process of punching and forming is in one flow and a synchronized operation, thereby providing dimensional accuracy and contour uniformity consistently.

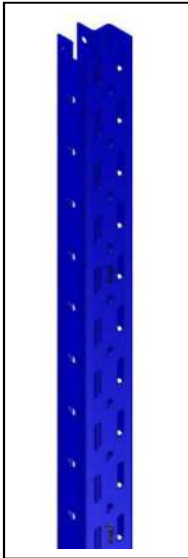

Upright type	GL
Profile	"T" profile
Profile width	55mm
Profile depth	45mm
Number of bend	6nos
Beam adjustability	50mm
Material Quality	Min Ys= 355 Mpa
Mfg process	Roll forming
Finish	Powder coated
Colour	Oxford Blue
Thickness	1.6 mm

Base plate

It is a formed construction bolted to upright. They are anchored to ground using M8x75 torque type mechanical anchor bolts. Floor level variation shall be adjusted with shims

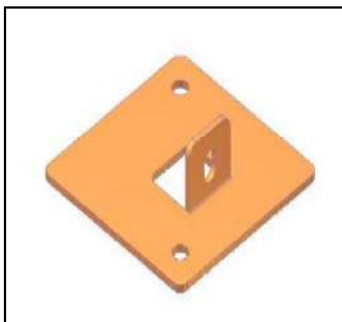

Width	100mm
Depth	100 mm
Connectivity	Grouting
No of exp bolt	2 no of M8x75
No of fasteners to connect upright	1 no of M8x20
Mfg process	Press forming
Finish	Powder coated
Colour	Orange
Thickness	3.15 mm

Bracing

Diagonal and horizontal bracings are lipped channel sections. These are to connect uprights to make frames. These bracing channels are also made through roll forming technology.

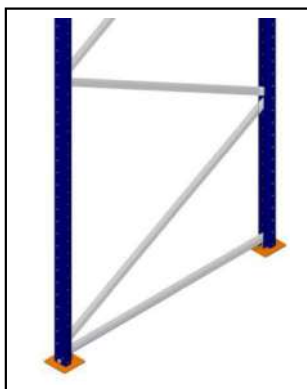

Type of profile	Lipped channel
Profile section	25 x 20 x 6mm
Mfg process	Roll forming
No of bend	4nos
Connectivity	Bolted
No of fasteners	2 no of M6x30
Surface finish	Galvanized
Colour	Galvanized
Thickness	1.4 mm

Row connector

Row connectors are to connect back to back frames. This is used when double faced racks are required in a solution. They ensure the stability of the system.

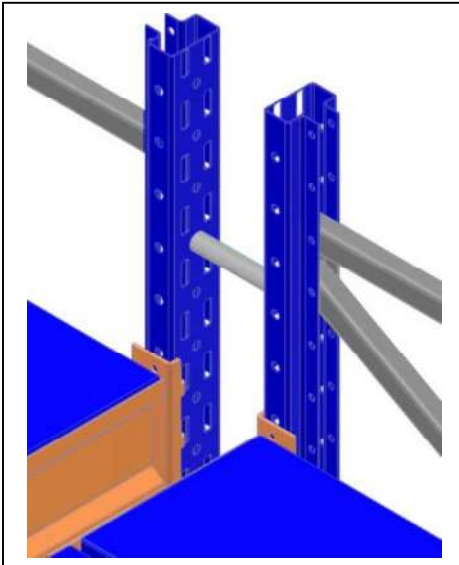

Type of profile	Pipe
Dia	17mm
Material thickness	2mm
Connectivity	Bolted
Fasteners	1 no of M8x75/125
Surface finish	Galvanized



Beam

Beams are of horizontal members connecting two frames, which support the decking panels. Beam locks by locking pins or locking clips that ensure beams are engaged with uprights precisely and prevent any accidental beam dislodgement due to handling.

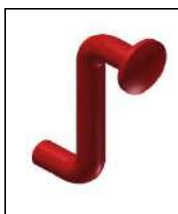
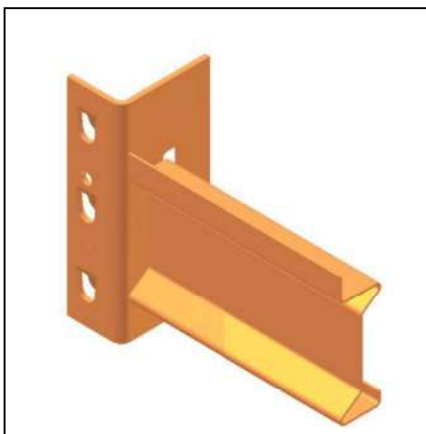

Type of Profile	'Z' Profile
Usage	For supporting decking panel
Height	85
Width	30mm
Type of lip connector	3Lip
Mfg process	Roll forming & welding
No of bend	8nos
Locking mechanism	Z shaped locking pin
Dia of locking pin	Dia 6mm
Tie bracket	Yes
No of tie bracket / level	One
Surface finish	Powder coated
Colour	Orange
Thickness	1.5 mm

6 Bend decking panel - LS

6 Bend decking panels are formed section having 6 bends. Both ends of the panel have notches facilitating the seating of panel on the beam.

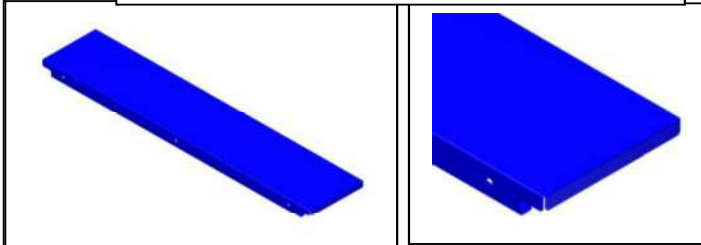
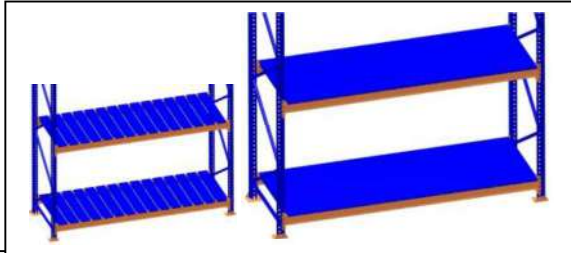

Width	150/200mm
Height	30mm
No of bend	6nos
Gap between panel	0mm
Sharp edges	No sharp edges in loading side
Mfg process	Press formed/Roll forming
Connectivity	Interconnected
Fasteners	2no of panel connectors
Surface finish	Powder coated/Galvanized
Colour	Oxford Blue
Thickness	0.7 mm

Panel connectors

It is the plastic connector used in 6-Bend Panel decking to inter-connect two panels without gap. This panel connector is designed with a feature of inserted-self locking type. Once it is installed, it is difficult to remove without breaking.

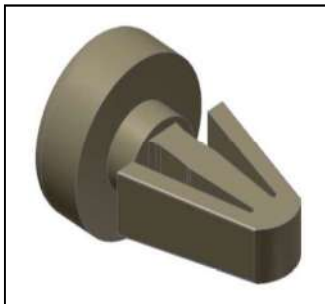

Material	Plastic
Usage	Interconnecting Panel
Qty per panel	2
Length	32mm
Colour	Black

Walkway assembly

Walkway is a platform/floor/walk way provided in multi-tier system on each landing level to access the decking levels for storing and picking the goods. This facilitates man and hand pallet truck (HPT) or Trolley movement.

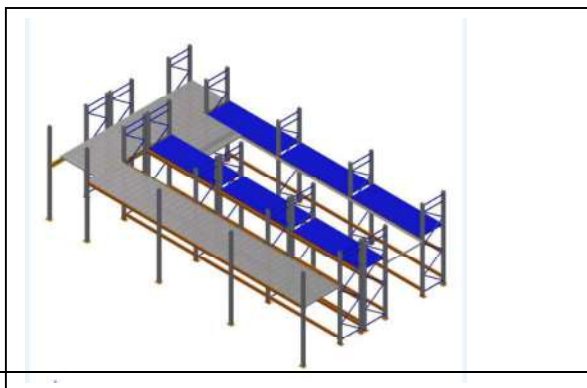

Walkway assembly

Walkway panel is roll formed construction made in single piece without welding. Walkway panel acts as flooring in multi tier system. They are designed to offer maximum load bearing capacity with high standards of stability and safety. Height of panel is 45mm & it has side slots for inter-bolting and slots at lips for bolting to the walkway beam.

The manufacturing process of punching and forming is in one flow and a synchronized operation, thereby providing dimensional accuracy and contour uniformity consistently.

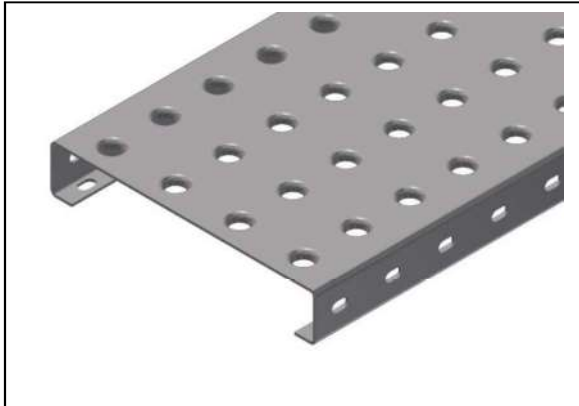

Catwalk material	Steel
Width of panel	150,200
Type	Hole
Mfg process	Roll forming
Support member	Channel member /Joist tube
Panel Clamp	2Nos / Panel
Pitch of support member	Max. 1500mm
Connectivity	Inter Bolting at 500mm pitch
Fastener	M8x30 Hex bolt & Nut
Max Load capacity	300 to 600 Kg/m ² UDL
Surface finish	Galvanized (275 GSM)
Thickness	1.6 mm

Walkway Gap Panel

Walkway gap panel is manufactured by bending operation. It is provided to fill the gap between walkway panels in an Aisle. It is generally installed at the end of the Aisle/junction of Picking or Cross Aisle. Height of the panel is 47mm & it has slots for bolting with the walkway panel.

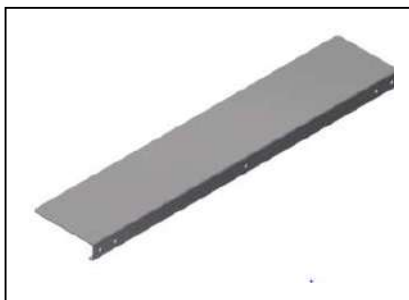

Height	47
Width of panel	150,200
Mfg process	Punching & Bending
No of bends	2
Connectivity	Bolting
Surface finish	Galvanized(275GSM)
Thickness	2.3 mm

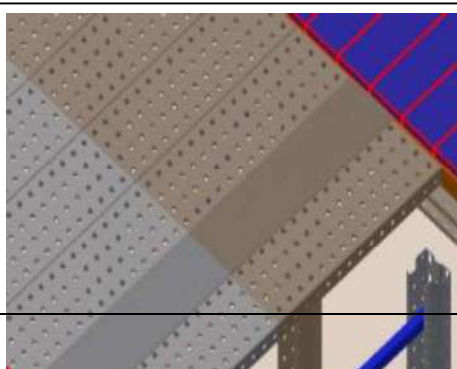

Panel Fixing Clamp

Panel fixing clamp connects picking aisle channel/frame channel and walkway panel by bolting the clamp with the walkway panel. This clamp will be provided at any one lip of panel.

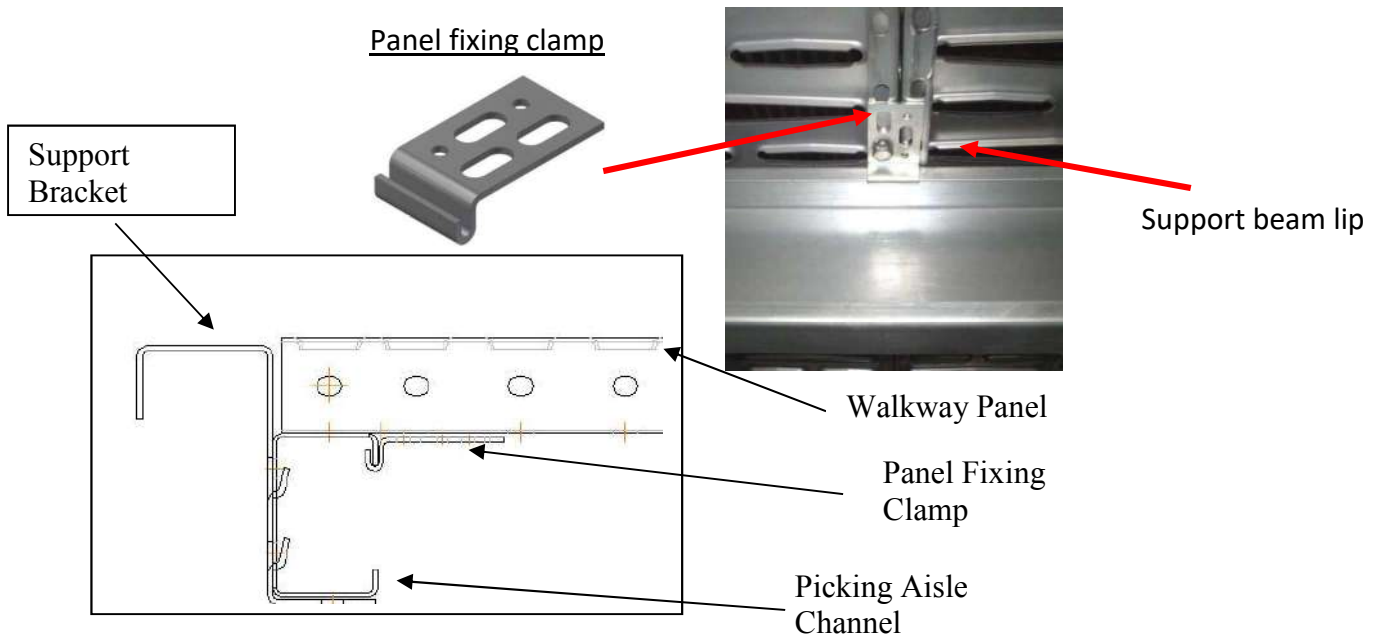

Frame channel has 'C' lipped section with series of slots at 50mm pitch and standard length of 2425mm. This channel is bolted to the upright side holes in cross Aisle/Overhang cross Aisle.

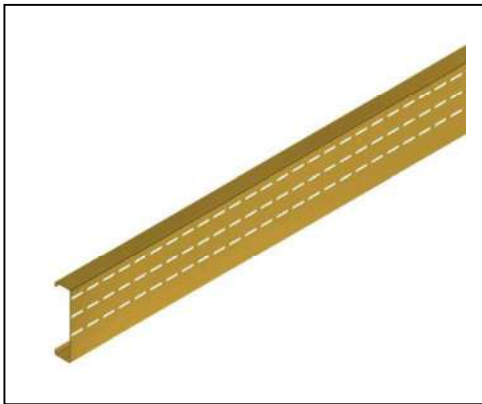

Section	Channel
Profile height	110,150,200,245,350
Mfg process	Piercing & Bending
No of bends	4
Connectivity	Bolting
Surface finish	Powder coating/Galvanized
Thickness	1.6 mm

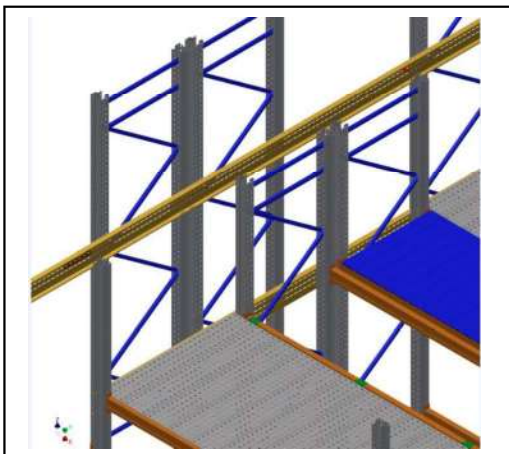

Railing

It is the ERW pipe provided in Overhang catwalks and end of the working aisle for safe walking. It is provided as three rows said to be a hand rail and knee rails. The dimensional position is shown below.

Railing pipe is bolted to the upright by railing clamp and open ends of the rails are blocked by Railing cap. Up-to 6 meter length single pipe is provided, beyond that joining will be there.

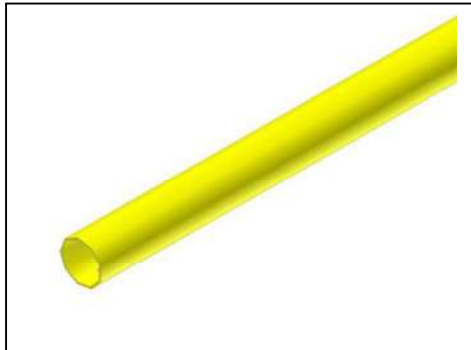

Size of railing pipe	Dia 38
Height of rail	1200mm
Connecting member	Railing clamp
Surface finish	Powder coated
Colour	Yellow
Thickness	1.6mm

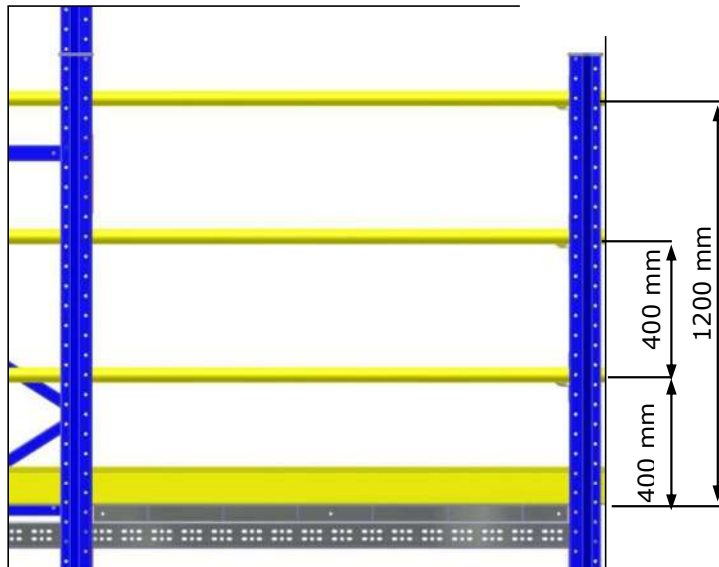

Railing clamp

It is for fixing Railing pipe (Hand Rail & Knee Rail) with the upright for catwalk safety. The plastic Profile of the clamp has a hole for fixing railing pipe and slot on clamp is used to fix it with upright.



Railing cap



It is the end dummy cap provided at opening ends of railing pipe. It is a Plastic cap suitable for dia38 pipe.

It is the 'L' section, provided over the catwalk surface on both sides of aisle. This plate prevents the foot slip through the gap between knee rail and catwalk surface while walking. It is fixed using M5x25 self tapping screw at 500mm pitch.

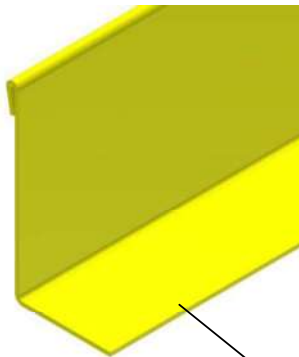

Material	Steel
Height	100mm
Mfg process	Press forming
No of bend	3nos
Fastener	M5x25 at every 500mm pitch
Surface finish	Powder coated
Colour	Yellow
Thickness	1.5 mm

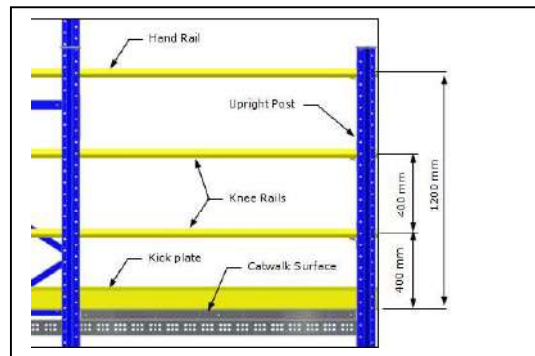

Staircase

Staircase is an independent, in-built unit with multi-tier system for reaching one floor to another floor (or) tier to tier. This is provided at a specific area of a shelving layout, where it is easy to access.

The staircase unit comprises of fabricated Side channel with railing unit as a single member in LH & RH variety, which is bolted with step panels. The typical single tier fabricated staircase is shown in below fig.

Generally single tier staircase has single landing level and multi-tier staircase has minimum two landing levels.

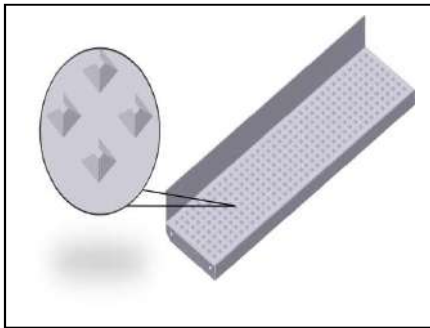

Inclination	36 deg
No of tiers	2
Steps	Anti- skid (embossed type)
Thickness of steps	2mm
Kickplate on steps	Yes
Step depth	275mm
Clear width	725mm
Step to step height	~ 190mm
Rail height	1200mm
Colour of step	Galvanized
Colour of staircase	Yellow

Safety Signage

These signage's are for the safety of warehouse personnel and longer life of the storage system. Quantity of signage's will be based on the layout.

Size	470x310mm
Thickness	5mm
Connectivity	Bolted
Quality	Photo print

6.2 TECHNICAL SPECIFICATIONS:- – BOLTLESS MULTI TIER SHELVING UNIT TYPE -B

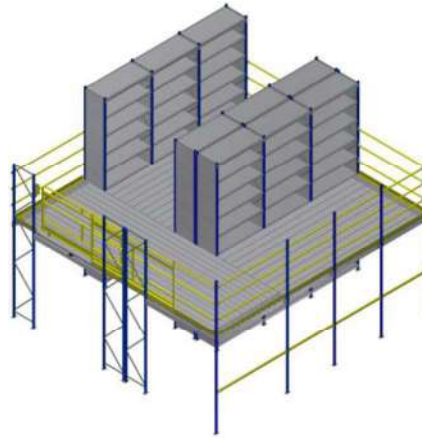

Design

Using following standards, as applicable for design of its boltless shelving system.

BS: 5950 (V): 1998 – Building design using cold formed steel sections.

FEM 10.2.06 – Code of practice for design of hand loaded static steel shelving system.

SEMA - Code of practice for the design of High and Low Rise Static steel shelving

Raw material

Load bearing members & accessories are made up of relevant high strength steel & the different types of materials used are:

Steel Type	Minimum guaranteed yield strength	Applicable standards	Component Usage
Galvanized	255 Mpa	ASTM A 653M SS GRADE 37 (CLASS 1)	Shelf Clip, Walkway Beam & Clamps, Walkway Panel, G50 base Plate
Galvanized	210 Mpa	IS:277 D	G50 Upright, Shelf Panel, G50 inner cladding
HR	255 Mpa	IS: 5986 – ISH410S / Equivalent (or) IS:2062 - E 250/ Equivalent JIS 3101: SS 400 EN 10025 : S 235	G55 Upright, G55 base plate
CR	210 Mpa	IS:513 D DIN 17100 : St 42 JIS ; G3141	Peripheral Claddings

In addition to high strength, the raw material used for structural load bearing members possesses adequate ductility to ensure toughness. The material also has the necessary impact strength for cold room applications up to -30 deg C.

Fasteners

Being boltless shelving, this system uses NO bolts for assembly of panels, panel stiffeners, back tie, fixed dividers, stability beam, and divider bar. And very minimal fasteners are used in allied products such as stair case, catwalk when compared to other similar products. All these fasteners are of grade 8.8.

Anchor bolts are of grade 5.8. All fasteners are with galvanized finish to suit industrial atmosphere.

Surface finish

Galvanized components:

Galvanizing protects steel from corrosion by providing a thick, tough metallic zinc envelope, which completely covers the steel surface and seals it from the corrosive action of its environment. The galvanized coating provides outstanding abrasion resistance. Where there is damage or minor discontinuity in the sealing coat of zinc, protection of the steel is maintained by the cathodic action of the surrounding galvanized coating. And Minimum GSM will be 120.

Powder-coated components:

For long life and protection from corrosion, All Powder coated components are given a thorough anti-rust treatment. The dry film thickness (DFT) after powder coating would be average 35 microns.

All powder coated components are subjected to an elaborate 4 step, six zone anti corrosion treatment, viz. De-greasing as per IS 6005:1970, rinsing, phosphating as per IS 3618:1966 and RO water rinsing.

Furthermore, the testing of paint for various physical and chemical properties is done as per ASTM Standard.

Assembly & Installation

In this system, unit assembly which comprises upright, panel & bracing are without bolts. Then base plate is bolted to every upright. Uprights are grouted on floor using expansion bolts. No welding will be carried out at site.

Component Specification

Upright G55

Upright is roll-formed construction made up of single piece having slots at 50mm pitch. It enables the warehouse manager to utilize the rack optimally to suit the changing SKU sizes. Uprights are bolted to base plates that transfer the load to ground.

The manufacturing process of punching and forming is in one flow and a synchronized operation, thereby providing dimensional accuracy and contour uniformity consistently.

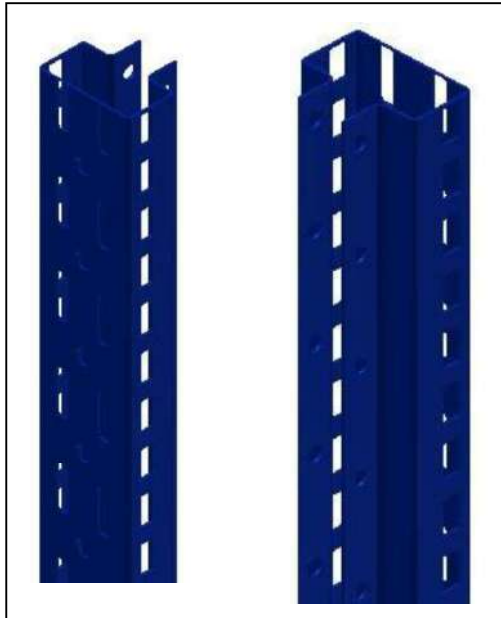

Upright type	Upright G55
Profile width	55 mm
Profile depth	45 mm
No of pieces	Single
Panel adjustability	50 mm
Material quality	Min Ys=255 Mpa (1.2 thk)
Mfg process	Roll forming
Finish	Powder coated
Colour	Oxford blue
Length	4100 mm
Bends	6 bends

Bracing G55

‘D’ type of bracing is used in G55 upright frames. It is a roll-formed, single piece section which connects two vertical uprights & makes a frame.

Bracings are the key members in maintaining the system stability. These are bolted into G55 uprights.

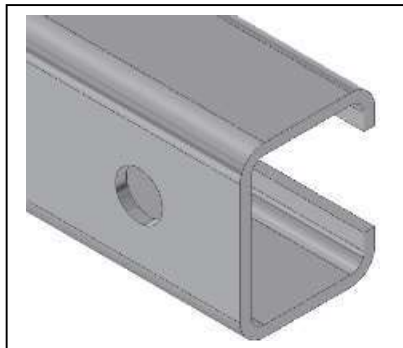

Type of profile	Lipped ‘C’ channel
Profile section	25 x 20 x 6mm
Mfg process	Roll forming
No of bend	4nos
Connectivity	Bolted
No of fasteners	2 no of M6x30
Fastener type	Hex. Bolt & Nut
Surface finish	Galvanized
Thickness	1.2 mm

Base plate G55

Base plates are used to transfer the upright load into ground & also act as a connecting member between ground & upright.

They are bolted into G55 upright by using M8x20 hex bolt & anchored to ground using M8x75 expansion anchor bolt.

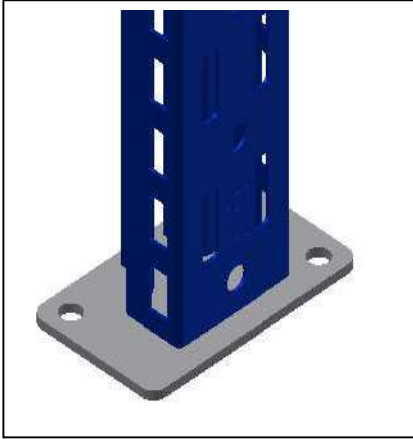
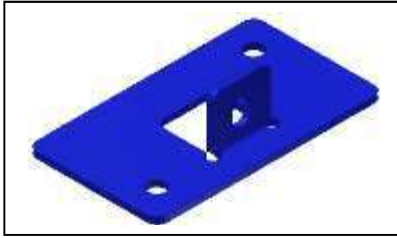

Width	111mm
Depth	66mm
Connectivity	Grouting
No of anchor bolt	2 nos. of M8x75
Fastener type	Expansion bolt
No of fasteners to connect upright	1 no of M8x20
Fastener type	Hex. Bolt
Mfg. process	Press forming
Finish	Powder coated
Colour	Oxford Blue
Thickness	3.15 mm

Shelf Panel

Shelf panels are the load carrying members which are hooked into the uprights via shelf clips. '4' nos. of clips are used per panel.

Mounting shelf panel is very easy in this boltless shelving system when compared to any other similar shelving system.

It is a roll-formed section with 14 bends.

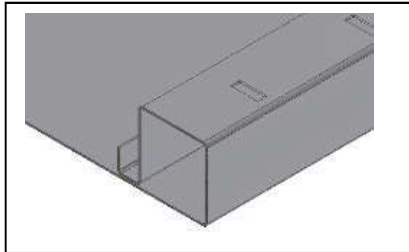
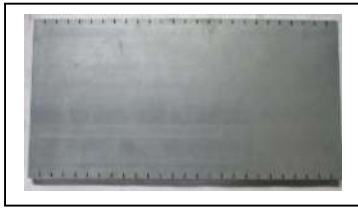

Width side – Cross Section

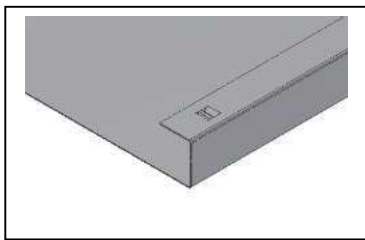

Depth side – Cross Section

Width	1300 mm
Depth	600mm
Range where panel cannot be offered	Refer shelf panel load chart
Height	32mm
No of bends	14
Sharp edges	No sharp edges
Mfg. Process	Roll formed
Usage	Decking surface
Fasteners	No
Divider Adjustability	50mm
Mounting	Using '4' nos. of shelf clips
Surface finish	Galvanized
Thickness	0.8mm

Shelf Clip

Shelf panels are mounted using this shelf clips. These are replacing the fasteners to mount panels with upright.

And while changing the levels of panels, these clips can be placed into the upright without any additional tools.



Profile section	70 x 17 x 12mm
Mfg. process	Blanking & Punching
No of bend	2
Connectivity	Insertion
Surface finish	Galvanized



Stability beam G55

Stability beam as the name itself describes that it provide stability to the system. Though it is not direct load carrying member it acts as supporting member between G55 uprights. It is bolted to the G55 upright via 4 bolts i.e. ‘2’ bolts on either side.

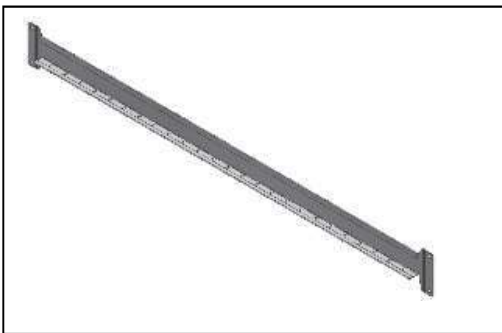

Profile section	125 x 30 mm
Mfg process	Notching & Folding
Connectivity	Bolted
Fastener type	Hex. Bolt
No of fasteners to connect upright (Extreme)	2 no's of M8x20
No of fasteners to connect upright (Common)	2 no's of M8x20
Surface finish	Powder coated

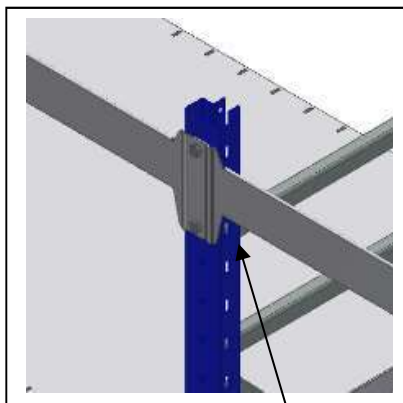
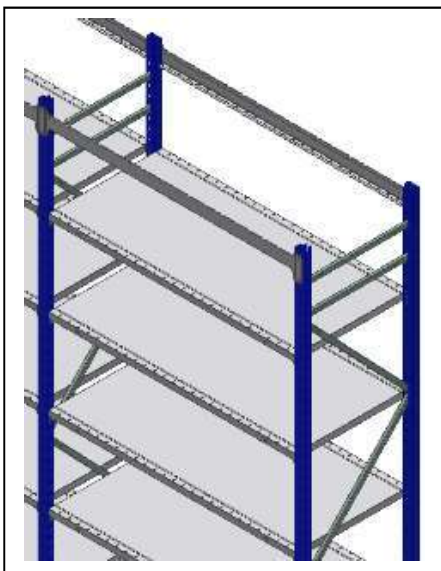

Stability beam – overlapped assembly for middle upright

Back tie – G55

Back ties are the critical members in ensuring stability. Back tie rod cleat is bolted into G55 upright & then turn buckle is hooked to it. Then back tie rod is hooked to turn buckle & opposite back tie rod cleat. Tie rod is common for G50 & G55 upright sections.

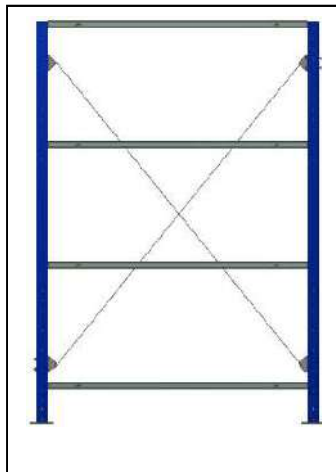

Usage	Stability
Dia of tie rod	5mm
Size of turn buckle	90mm
Connectivity – tie rod cleat	Bolting
Fastener type	Hex. Bolt
Fasteners	‘2’ nos of M8x20 & ‘2’ nos of M8 washers per cleat
Mfg process – tie rod	Bending
Surface finish	Galvanized

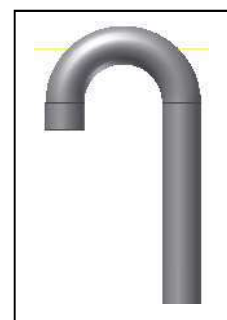
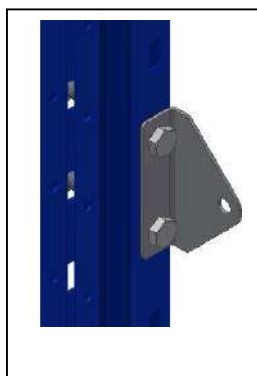

G55 Row connector

This component used to connect two G55 uprights back to back when configured as a DF system. Default gap to maintained between two SF system is ‘30’mm.



Profile	Round tube
Material thickness	1.6 mm
Mfg process	Tube cutting, turning
Length	29mm
Connectivity	Bolting
Fastener	‘1’ No of M8x50 Hex bolt & Nut/ connector
Surface finish	Galvanized



G55 Row connector

Walkway assembly

Walkway surface is the roll formed panel having cross section of lipped 'C' with '4' bends having louvered holes / slots that is designed to cater the multiple needs of the high rise shelving system.

Height of panel is 45mm & it has side slots for inter-bolting and slots at lips for bolting to the walkway beam.

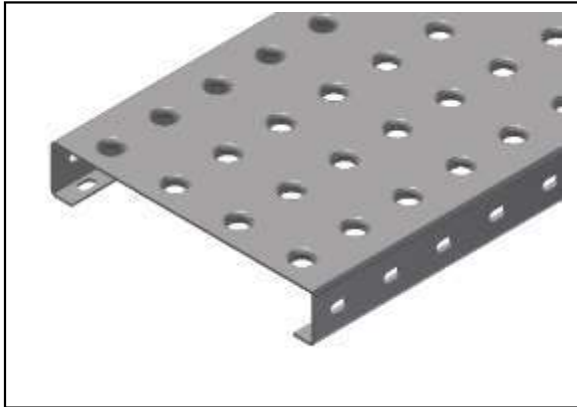

Catwalk material	Steel
Width of panel	200
Type	Hole
Mfg process	Roll forming
Support member	Walkway beam
Panel Clamp	Qty / Panel = No of instances of panel joining with walkway beam
Pitch of support member	Max. 1500mm
Connectivity	Inter Bolting at 500mm pitch
Fastener	M8x15 Hex bolt & Nut
Max Load capacity	300 Kg/m ² UDL
Surface finish	Galvanized

Other catwalk components & Safety membe Railing

It is the ERW pipe provided in Overhang catwalks and end of the working aisle for safe walking. It is provided as three rows said to be a hand rail and knee rails. The dimensional position is shown below.

Railing pipe is bolted to the upright by railing clamp and open ends of the rails are blocked by Railing cap. Up-to 6 meter length single pipe is provided, beyond that joining will be there.

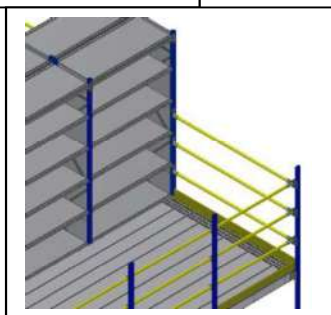
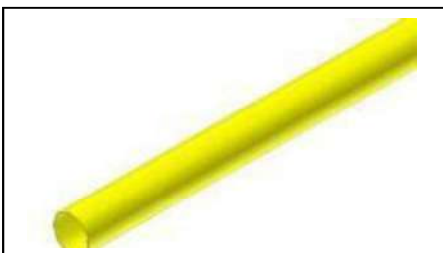

Size of railing pipe	Dia 38
Height of rail	1200mm
Connecting member	Railing clamp
Surface finish	Powder coated
Colour	Ochre Yellow

Kick plate

It is the 'L' section, provided over the catwalk surface on both sides of aisle. This prevents the foot slip through the gap between knee rail and catwalk surface while walking. It is fixed using M5x25 self tapping screw at 500mm pitch.

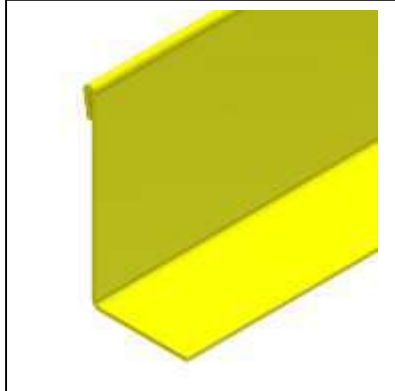

Material	Steel
Height	100mm
Mfg process	Press forming
No of bend	3nos
Fastener	M5x25 self tap screw at every 500mm pitch
Surface finish	Powder coated
Colour	Ochre Yellow
Thickness	2 mm

Railing Clamp

It is for fixing Railing pipe (Hand Rail & Knee Rail) with the upright using M8x30 Hex bolt & Nut. The plastic Profile of the clamp has a hole for fixing railing pipe and slot on clamp is used to fix it with upright.



Railing Clamp

Railing Cap

It is the end cap provided at opening ends of railing pipe. It is a Plastic cap with metal cover suitable for dia38 pipe.



Railing Cap

Staircase is an independent / in-built unit with multi-tier system for reaching one floor to another floor (i.e.) tier to tier. This is provided at a specific area of a shelving layout, where it is easy to access.

The staircase unit comprises of fabricated Side channel with railing unit as a single member in LH & RH variety, which is bolted with step panels. The typical single tier fabricated staircase is shown in below fig.

Generally single tier staircase has single landing level and multi-tier staircase has minimum two landing levels.

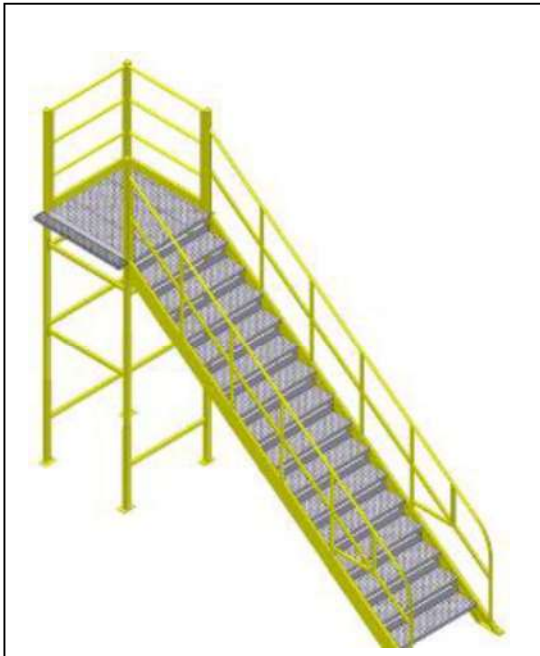

Inclination	36 deg
No of tiers	2
Steps	Anti- skid (embossed type)
Thickness of steps	2mm
Kick plate on steps	Inbuilt with step panel
Step depth	275mm
Clear width	725
Step to step height	~ 190mm
Rail height	1200mm
Colour of step	Galvanized
Colour of staircase	Yellow

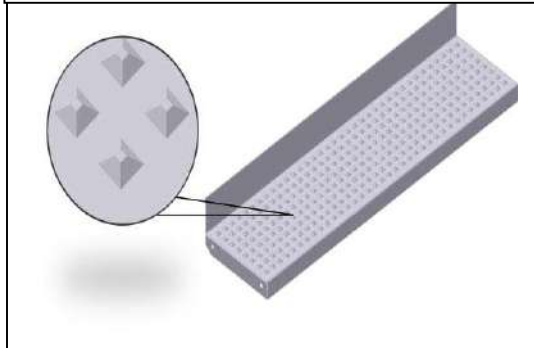

6.3 TECHNICAL SPECIFICATIONS:- CANTILEVER

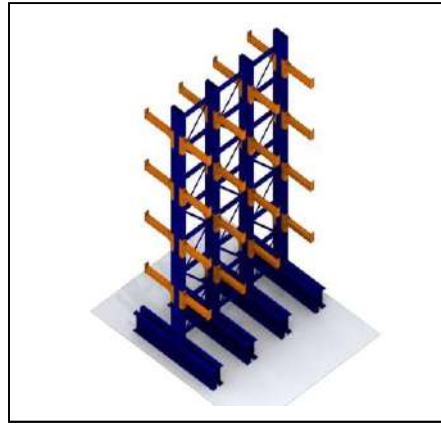

Design

Uses the following standards, as applicable for design.

IS 801: 1975 - Code of practice for use of cold formed light gauge steel structural member's in general building construction.

IS 800: 1984 /2007 - Code of practice for general construction in steel

Raw material

The components like Upright, Base channel, Cantilever arm and Bracing Channel are to be manufactured from superior quality of Hot Rolled Sheet of Steel conforming to IS 2062:2006, E250 (Fe 410), IS-5986-ISH410S with minimum yield stress 255Mpa..

Design Guidelines – Cantilever Racking System comprising of uprights, base channels, arms & bracings are to be bolted to make basic framework. **No welded frame structure**, so as to afford flexibility in assembly & level adjustment in future and to avoid fabrication work at site. The racking components are to be designed with a minimum factor of safety of 1.67 with respect to yield stress and not Ultimate Tensile Strength as per Design code IS 800/801.

Upright – Upright is to be made of formed construction made in two pieces having 4 bends on its profile with slots at 100 mm pitch for level adjustment and to cater future requirement. Uprights are to be grouted to the floor by using required nos of galvanized expansion bolts.

Cantilever Arm – The Arms are to be designed to limit the deflection to the ratio of length of the arm divided by 200 (i.e. Deflection < Span/200). Arms are to be box type construction. Box construction are to be LC profile welded together to form a closed structure

Diagonal and Horizontal Bracing Channels – Lipped 'C' sections are used for Horizontal bracings & Diagonal bracings are made of angles flattened on both sides

Fasteners

All fasteners used are of grade 8.8. These are with galvanized finish to suit industrial atmosphere.

Surface finish

For long life and protection from corrosion, Book stack components are given a thorough anti-rust treatment. All steel components unless otherwise specified are powder coated for obtaining a smooth, scratch resistant and lasting attractive finish. The Dry Film Thickness (DFT) after powder coating would be average 40 microns.

All components are subjected to an elaborate 4 step, six zone anti corrosion treatment, viz. De-Greasing as per IS 6005:1970, Rinsing, Phosphating as per IS 3618:1966 and RO water rinsing.

Furthermore, the testing of paint for various physical and chemical properties is done as per ASTM Standard.

Assembly & Installation

The cantilever system is completely knock down construction. The racks are grouted on to the floor using expansion bolts. No welding will be carried out at site.

Racking component specification

Box upright

Box upright is a formed lipped profile welded together to form a closed structure. It is supported by the base channel at bottom. The successive hole pitch of box upright is 100mm.

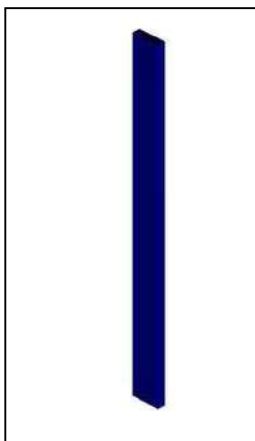

Profile	Box
Profile width	350mm
Profile depth	100mm
Fasteners	M12 x 25mm
Mfg process	Press forming & welding
Finish	Powder coated
Colour	Oxford blue
Thickness	3.15 mm

Base channel

Base channel is a formed "C" profile & it is connected at the either side of upright. Base channel is grouted at the floor. It plays a major roll in cantilever racking system. The entire load transfer is base on the base channel.



Profile	“C” Section
Profile width	350mm
Profile depth	50mm
Expansion bolts	M12 x 100mm
Mfg process	Press forming
Finish	Powder coated
Colour	Oxford blue
Thickness	3.15 mm

Horizontal bracing

Horizontal bracings are lipped channel profile. These are to connect uprights to make frames. These bracing channels are also made through roll forming technology. The successive horizontal bracing distance should be 900mm. The first horizontal bracing is 100mm above the base channel, irrespective of the height of the base channel.

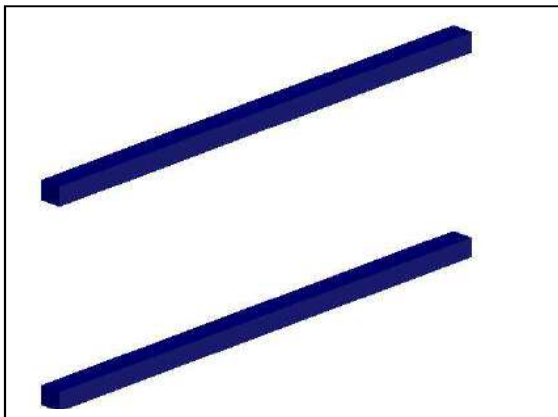

Type of profile	Lipped profile
Profile section	75 x 50mm
No of bend	4nos
Connectivity	Bolted
Fasteners	M10 x 25mm
Surface finish	Powder coated
Colour	Oxford blue
Thickness	2 mm

Diagonal bracing

Diagonal bracing is a angular formed section flatted on both end These are to connect horizontal bracing to make frames. These bracing channels are also made through roll forming technology.

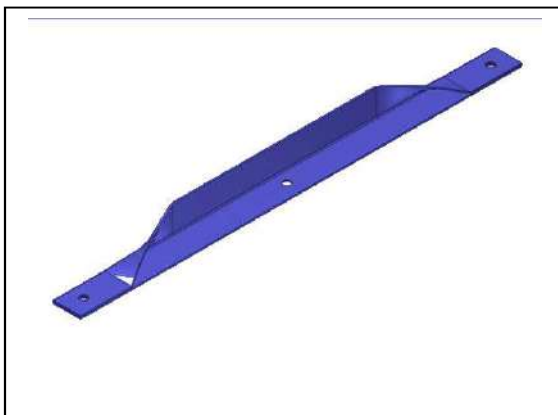

Type of profile	Angle
Profile section	41 x 41mm
No of bend	4nos
Connectivity	Bolted
Fasteners	M10 x 25mm
Surface finish	Powder coated
Colour	Oxford blue
Thickness	2.5 mm

Arm

Cantilever arm is a formed section has tubular profile capable to take level load. At the end of arm stopper are provided to avoid the SKU flow down. Gussets are welded at the top & bottom of arm for rigidity.

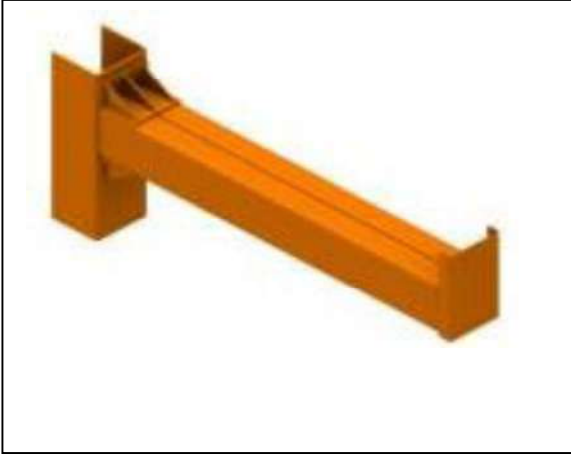

Type of profile	Tube profile
Profile section	100 x 50mm
Profile thickness	2.95 mm
No of bend	4nos
Connectivity	Bolted
Fasteners	M10 x 25mm
Surface finish	Powder coated
Colour	Orange

6.4 TECHNICAL SPECIFICATIONS:- Heavy Duty Shelving System Type-C

Design

Uses the following standards, as applicable for design.

Racking Codes:

ANSI-MH-16.1-2008	Specification for the design testing & utilization of industrial steel storage racks (American)
BS EN 15512:2009	Steel static storage systems - Adjustable pallet racking systems – Principles for structural design (European)
SEMA	Code of practice for the Design of Adjustable Pallet Racking (British)

Structural Design Codes:

IS 801 - 1975	Code of Practice for use of Cold-formed Light Gauge steel structural members in General Building Construction
IS 800 – 2007	General Construction in Steel - Code of Practice
BS 5950 – Part V	Structural use of steelwork in building - Part 5 - Code of Practice for design of cold-formed thin gauge sections (British)
EN 1993-1- Part 3	Design of steel structures. General rules. Supplementary rules for cold-formed members and sheeting (European)
AISI -1996	Cold Formed Steel Design Manual – American Iron and Steel Institute (American)

Tolerances:

BS EN 15620 - 2008	Steel static storage systems - Adjustable pallet racking – Tolerances, Deformations and clearances (European)
SEMA	Guideline No 2 - Guide to Erection Tolerances for Static Racking (British)

Raw material

Load bearing members of the system are made out of high strength HR steel having properties equivalent to grades specified by IS 5986:2002 / IS 2062:2006

The different types of material used for load bearing members such as uprights and beams are:

Steel type	Minimum guaranteed yield strength	Equivalent international standard
IS: 5986 – ISH430LA / Equivalent	355 MPa	JIS 3101: SS 490

(or) IS:2062 - E 350 / Equivalent		EN 10025 : S 355 JR DIN 17100 : St 52
IS: 5986 – ISH410S / Equivalent (or) IS:2062 - E 250 / Equivalent	255 MPa	JIS 3101: SS 400 EN 10025 : S 235 JR DIN 17100 : St 42
IS:3601 – 2006 / Equivalent IS:4923 – 1997 / Equivalent	210 Mpa	
IS :513 – 2008 / Equivalent	210 Mpa	JIS 3141
	355 MPa	ASTM A 653 M SS GRADE 50
	255 MPa	ASTM A 653 M SS GRADE 37
IS 277'D'	210 Mpa	

In addition to high strength, the raw material used for structural load bearing members, posses adequate ductility, to ensure toughness. The material also has the necessary impact strength for cold room applications up to -30 deg C.

Fasteners

All fasteners used are of grade 8.8. These are with galvanized finish to suit industrial atmosphere.

Surface finish

For long life and protection from corrosion, All Powder coated components are given a thorough anti-rust treatment. The dry film thickness (DFT) after powder coating would be on an average 35 microns.

All powder coated components are subjected to an elaborate 4 step, six zone anti corrosion treatment, viz. De-greasing as per IS 6005:1970, rinsing, phosphating as per IS 3618:1966 and RO water rinsing.

Furthermore, the testing of paint for various physical and chemical properties is done as per IS ASTM Standards.

Upright is roll formed construction made in single piece without welding. Upright has slots at 50 mm. It enables the warehouse manager to utilize the rack optimally to suit the changing SKU sizes.

Uprights are multi bend profiles, designed to offer maximum load bearing capacity with optimum surface utilization ensuring high standards of stability and safety. Uprights are bolted with Base Plates to transfer the load to ground.

The manufacturing process of punching and forming is in one flow and a synchronized operation, thereby providing dimensional accuracy and contour uniformity consistently.

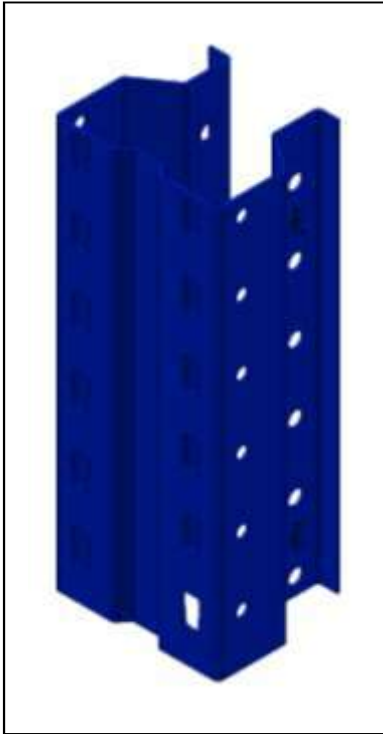

Upright type	GXL90
Profile	Omega
Profile width	90mm
Profile depth	70mm
Number of bend	12
No of pieces	Single
Beam adjustability	50mm
Material Quality	Min Ys= 355 Mpa
Mfg process	Roll forming
Finish	Powder coated/Galv
Colour	Oxford Blue
Thickness	1.6 mm

Base plate – 53mm

It is a Welded construction bolted to upright. They are anchored to ground using M12x100 Torque type mechanical anchor bolts. Floor level variation shall be adjusted with shims. This base plate is used with GXI

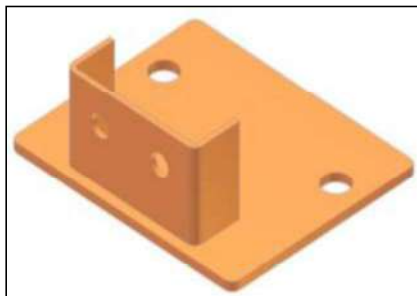

Width	180 mm
Depth	110 mm
Connectivity	Grouting
No of grouting bolts	2 no of M12x100
No of fasteners to connect upright	2 no of M10x25
Mfg process	Welding & press forming
Finish	Powder coated
Colour	Orange
Thickness	3.15 mm

Grouting fasteners

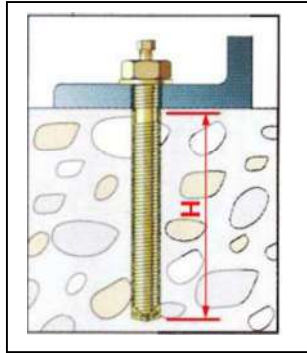

Type	Mechanical anchor (torque type)
Material	Mild steel
Finish	Zinc plated
Diameter	M12
Anchor depth	70mm

Bracing

Diagonal and horizontal bracings are lipped channel sections. These are to connect uprights to make frames. These bracing channels are also made through roll forming technology.

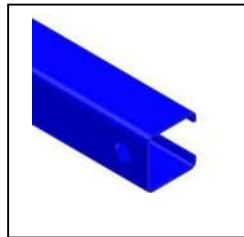
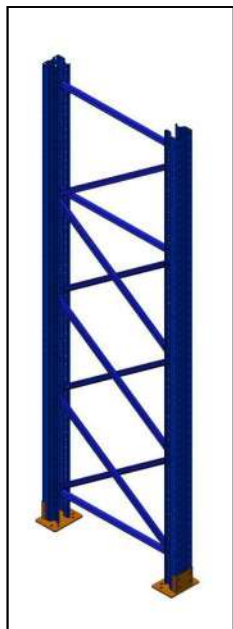
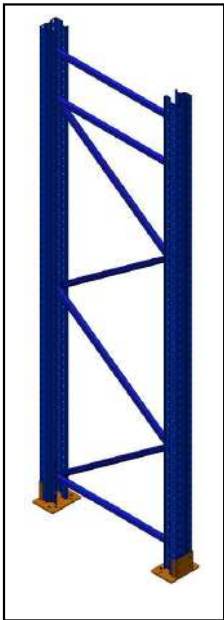

Bracing



Bracing Spacer

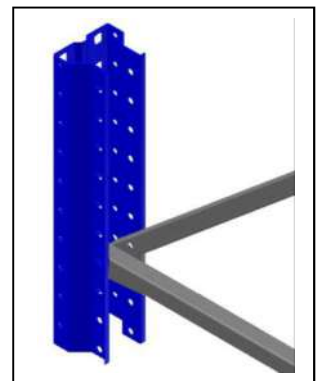

Type of profile	Lipped channel
Profile section	30 x 30 x 6mm
Mfg process	Roll forming
No of bend	4nos
Connectivity	Bolted
No of fasteners	2 no of M10x75
Surface finish	Galvanized
Colour	Galvanized
Thickness	1.5 mm

Row connector

Row connectors are to connect back to back frames. This is used when double faced racks are required in a solution. They ensure the stability of the system.

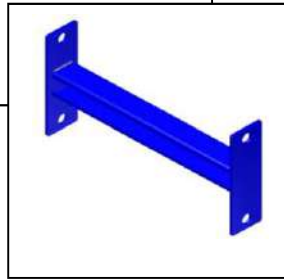
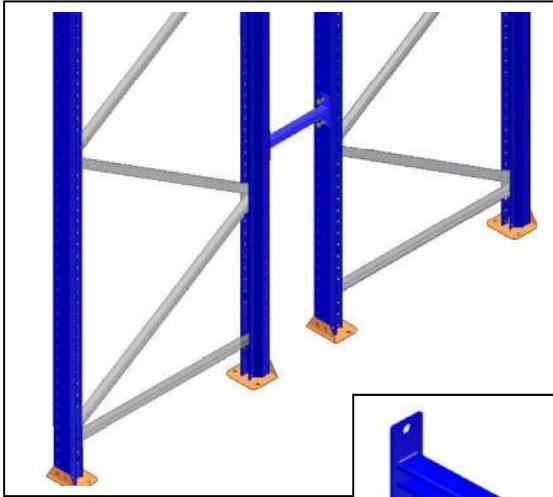

Type of profile	Lipped channel with Rectangular plates at end.
Profile section	30x30x6mm
No of bend	4nos
Mfg process	Roll forming & Welded
Connectivity	Bolted
Fasteners	4 no of M10x25
Surface Finish	Powder coated
Colour	Oxford Blue
Thickness	1.5 mm

Beam

Beams are of box type construction. Better strength for beams, since it is box profile, unlike open profiles which tend to buckle for heavy loads or for longer beam lengths. Beam top is 48mm width to provide larger surface area for resting decking surface.

Beam locks by locking pins or locking clips ensure that beams are engaged with uprights precisely and prevent any accidental beam dislodgement due to handling equipments.

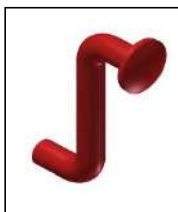
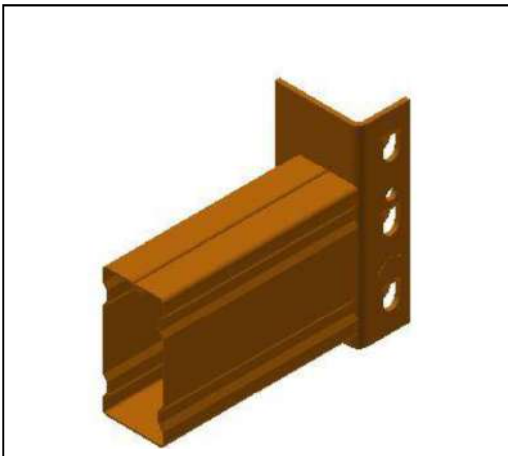

Type of Profile	Box
Height	110
Width	50
Type of Lip connector	4 Lip
Mfg process	Roll Forming & Welding
No of Bend	4+4 =8
Locking mechanism	Z shaped locking pin
Dia of Locking Pin	Dia 6mm
Surface Finish	Powder Coated
Colour	Orange
Thickness	1.5 mm

6 Bend decking panel -HD

6 Bend decking panels are formed section having 6 bends. Both ends of the panel have notches facilitating the seating of panel on the beam.

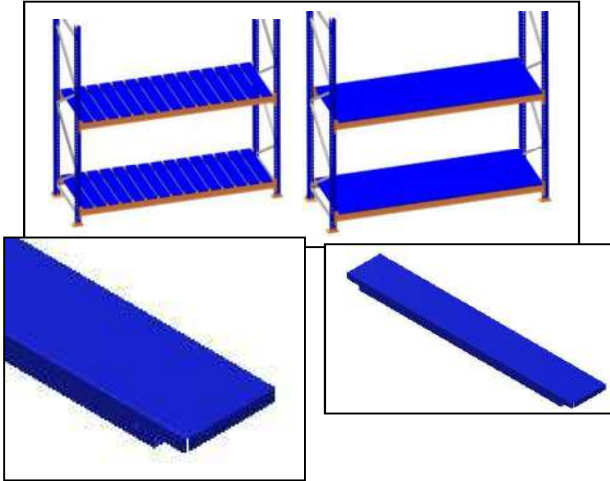

Width	150/200mm
Height	30mm
No of bend	6nos
Sharp edges	No sharp edges in loading side
Mfg process	Press formed/Roll forming
Gap between panel	0mm
Connectivity	Interconnected
Fasteners	Panel connector
Surface finish	Powder coated/Galvanized
Colour	Oxford Blue
Thickness	0.7 mm

Panel connectors

It is the plastic connector used in 6-Bend Panel decking to inter-connect two panels without gap. This panel connector is designed with a feature of inserted-self locking type. Once it is installed, it is difficult to remove without breaking.

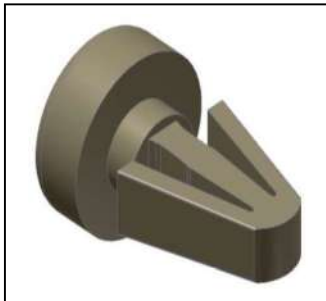

Material	Plastic
Usage	Interconnecting panel
Qty per panel	2nos
Length	32mm
Colour	Black

GENERAL CONDITIONS OF CONTRACT



NOIDA METRO RAIL CORPORATION LTD.

(A joint venture of Govt. of India and Govt. of U.P.)

JUNE 2020

GENERAL CONDITIONS OF CONTRACT

NOIDA METRO RAIL CORPORATION LTD.

BLOCK -III,3rd FLOOR, GANGA COMPLEX,

SECTOR -29.NOIDA-201 301

DISTRICT GAUTAM BUDH NAGAR,UTTAR PRADESH,INDIA

[Handwritten signatures in blue ink]

26

GENERAL CONDITIONS OF CONTRACT

Clause No.	Description	Page No.
1	DEFINITIONS AND INTERPRETATION	8
1.1	Definitions	8
1.2	Interpretation	13
1.3	Law and Language	13
1.4	Contract Agreement	13
1.5	Priority of Documents	13
1.6	Care and Supply of Construction and/or Manufacture Documents	14
1.7	Communications	14
1.8	Employer's Use of Contractor's Documents	14
1.9	Contractor's Use of Employer's Documents	15
1.10	Compliance with Statutes, Regulations and Laws	15
1.11	Joint and Several Liability	15
2	THE EMPLOYER	15
2.1	General Obligations	15
2.2	Access to and Possession of the Site	15
2.3	Permits, Licences or Approvals	16
2.4	Assignment by the Employer	16
3	THE ENGINEER	16
3.1	Appointment of Engineer	16
3.2	Duties and Authorities of the Engineer	16
3.3	Engineer's Authority to Delegate	16
3.4	Engineer's Instructions	17
3.5	Engineer to Attempt Agreement	17
4	THE CONTRACTOR	17
4.1	General Obligations	17
4.2	Performance Security Amount	18
4.3	Representation on Works	21
4.4	Facilities for and co-ordination with others	21
4.5	Sub-contractors	23
4.6	Assignment of Contractor's and Sub-contractor's Obligations	24
4.7	Compensation for Breach	24
4.8	Setting Out	24
4.9	Site Data	25
4.10	Sufficiency of accepted Contract Amount	26
4.11	Access Route	26
4.12	Rights of Way and Facilities	26
4.13	Programmes	26
4.14	Progress Reports	27
4.15	Contractor's Equipment	27
4.16	Safety of Works	27

GENERAL CONDITIONS OF CONTRACT

4.17	Protection of the Environment	28
4.18	Electricity, Water and Gas	28
4.19	Tools, Plants And Equipment Supplied By The Employer	28
4.20	Employer's Materials & Excavated Material	29
4.21	Sheds, Stores, Yards	29
4.22	Temporary Works	29
4.23	Unforeseeable Physical Conditions	29
4.24	Access for Engineer	30
4.25	Access Road and Way Leaves	30
4.26	Contractor to keep Site Clear	30
4.27	Security of the Site	30
4.28	Contractor's Operations on Site	30
4.29	Discoveries	31
4.30	Publicity	31
4.31	Disclosure Of Relationship	31
4.32	Use Of Explosives	31
4.33	Corrupt/Fraudulent/Collusive/Coercive Practices	31
5	DESIGN	33
5.1	General Obligations	33
5.2	Contractor's warranty of design	33
5.3	Construction and/or Manufacture Documents	34
5.4	Technical Standards and Regulations	35
5.5	Samples	35
5.6	As-Built Drawings and Documents	36
5.7	Operation and Maintenance Manuals	36
5.8	Intellectual Property Rights and Royalties	36
6	STAFF AND LABOUR	38
6.1	Engagement of Staff and Labour	38
6.2	Rates of Wages and Conditions of Labour	38
6.3	Persons in the service/ retired of Employer/Engineer	38
6.4	Labour Laws	38
6.5	Working Hours	39
6.6	Facilities for Staff and Labour	39
6.7	Health and Safety	39
6.8	Contractor's Superintendence	40
6.9	Provision of Efficient and Competent Staff	40
6.10	Preservation of Peace and orderly conduct	40
6.11	Labour to be Contractor's Employee	41
6.12	Report Of Accidents To Labour	41
6.13	Claim on account of violation of Labour laws	41

25A

GENERAL CONDITIONS OF CONTRACT

6.14	Maintenance of Records	41
7	QUALITY CONTROL	41
7.1	Manner of Execution	41
7.2	Source of Materials	41
7.3	Delivery to Site	41
7.4	Inspection	42
7.5	Testing	42
7.6	Rejection	42
7.7	Liability after Inspection and Testing	43
7.8	Ownership of Plant and Materials	43
7.9	Cost of Employer's Attendance Including Travel	43
7.10	Covering up of Works	43
7.11	Tests after Completion	44
7.12	Integrated testing and system commissioning	45
8	TIME MANAGEMENT	45
8.1	Commencement of Works	45
8.2	Time for Completion	46
8.3	Delay	46
8.4	Extension of Time for Completion	46
8.5	Liquidated Damages for Delay	47
8.6	Rate of Progress	48
8.7	Suspension of Work	48
8.8	Consequences of Suspension	49
8.9	Resumption of Work	49
9	EMPLOYER'S TAKING OVER	49
9.1	Taking Over Certificate	50
9.2	Taking over of Parts of the Works	50
10	DEFECTS LIABILITY	50
10.1	Completion of Outstanding Work and Remedying Defects	51
10.2	Cost of Remedying Defects	51
10.3	Extension of Contract Period	51
10.4	Failure to Remedy Defects	51
10.5	Removal of Defective Work	52
10.6	Further Tests	52
10.7	Right of Access	52

GENERAL CONDITIONS OF CONTRACT

10.8	Contractor to Search	52
10.9	Performance Certificate	52
10.10	Unfulfilled Obligations	53
10.11	Emergency Defect Rectification	53
11	CONTRACT PRICE AND PAYMENT	53
11.1	The Contract Price Inclusions/ Exclusions	53
11.2	Advances	54
11.3	Provisional Payment Against Material at Site	55
11.4	Application for Interim Payment Certificates	56
11.5	Issue of interim Payment Certificate	57
11.6	Payment – Interim & Final	57
11.7	Statement at Completion	58
11.8	Application for Final Payment Certificate	58
11.9	Discharge	58
11.10	Issue of Final Payment Certificate	58
11.11	Cessation of Employer's Liability	59
11.12	Calculation of Payments in Foreign Currency	59
11.13	Round off	59
11.14	Payment by Cheque & E-Payment	59
11.15	Tax Deduction at Source	59
11.16	Production of Vouchers	59
11.17	Withholding And Lien For Sums Claimed	60
11.18	Signature On Receipts For Payments	60
11.19	Post Payment Audit	60
11.20	Recovery of money due to the Employer	60
12	VARIATIONS	61
12.1	Right to Vary	61
12.2	Contractor's Variations	61
12.3	Employer's Variations	62
12.4	Variation Procedure	62
12.5	Variation in the Bill of Quantities	63
12.6	Payment in Applicable Currencies	64
13	TERMINATION OF THE CONTRACT	65
13.1	Notice to Contractor	65
13.2	Termination Of Contract Due To Contractor's Default	65

257

GENERAL CONDITIONS OF CONTRACT

13.3	Default of Employer	67
14	RISK AND RESPONSIBILITY	68
14.1	Indemnity	68
14.2	Contractor's Care of the Works	69
14.3	Employer's Risks	69
14.4	Consequences of Employer's Risks	70
14.5	Contractor's Risks	70
14.6	Limitation of Liability	70
15	INSURANCE	70
15.1	Professional Indemnity Insurance	70
15.2	Insurance for Works and Contractor's Equipment	71
15.3	Insurance Against Injury to Persons and Damage to Property	71
15.4	Insurance for Workers	71
15.5	General Requirements for Insurances	72
16	FORCE MAJEURE	73
16.1	Definition of Force Majeure	73
16.2	Effect of Force Majeure Event	73
16.3	Contractor's Responsibility	73
16.4	Employer's Responsibility	73
16.5	Payment to Contractor	73
16.6	Resumption of Work	73
16.7	Optional Termination, Payment and Release	74
16.8	Release from Performance under the Law	74
17	CLAIMS, DISPUTES, CONCILIATION AND ARBITRATION	74
17.1	Procedure for Claims	74
17.2	Payment for Claims	75
17.3	No Legal Action Till Dispute Settlement Procedure is Exhausted	75
17.4	Notice of Dispute	75
17.5	Two Stages for Dispute Resolution	75
17.6	Conciliation	75
17.7	Conciliation Procedure	75
17.8	Termination of Conciliation Proceedings	76
17.9	Arbitration	76
17.10	Interest on Arbitration Award	79
17.11	Cost of Conciliation/ Arbitration	79

GENERAL CONDITIONS OF CONTRACT

17.12	Jurisdiction of Courts	79
17.13	Suspension of Work on Account of Arbitration	79
18	SERVICE OF NOTICES	79
18.1	Notice to Contractor	79
18.2	Notice to Employer and Engineer	80
18.3	Change of Address	80

255

GENERAL CONDITIONS OF CONTRACT

1 DEFINITIONS AND INTERPRETATION

Definitions

- 1.1 In the contract (as defined below) the words and expressions defined below shall have the meanings assigned to them, except where the context requires otherwise. Words indicating persons or parties include corporations and other legal entities except where the context requires otherwise.
- 1.1.1 **Documents**
- 1.1.1.1 **"Appendix to Form of Tender"** means the completed pages in title Appendix, which are appended to and form part of the Tender.
- 1.1.1.2 **"Bill of Quantity"** means a document containing various items of payment and contains schedule of Payment also.
- 1.1.1.3 **"Construction and/or Manufacture Documents"** means all drawings, operation and maintenance manuals, and other manuals and information of a similar nature, to be submitted by the Contractor.
- 1.1.1.4 **"Contract"** means the Contract Agreement, the Letter of Acceptance, the letter of tender, General Conditions of Contract, Special Conditions of Contract, the Employer's Requirements, the Notice Inviting Tender, Instructions To Tenderers, the Contractor's Proposal, the Schedules, and such further documents which are listed in the Letter of Acceptance or Contract Agreement (in completed).
- 1.1.1.5 **"Contract Agreement"** means the contract agreement referred to in Sub-clause 1.4. It shall also include all subsequent modifications/ amendments to the Contract as a result of the communications or negotiation proceedings between the parties.
- 1.1.1.6 **"Contractor's Proposal"** means the proposal submitted by the Contractor with the Tender, as modified and accepted by the Employer and included in the Contract. Such documents may include the Contractor's preliminary design.
- 1.1.1.7 **"Contractor's Document"** means the calculations, computer programme and other softwares, drawings, manuals and other documents of a technical nature(if any) supplied by the Contractor under the Contract.
- 1.1.1.8 **"Design Data"** means all specifications, plans, drawings, details, graphs, sketches, models, levels, setting-out dimensions, calculations duly checked by the Contractor and other documents relating to the design of the Works prepared or to be prepared by or on behalf of the Contractor.
- 1.1.1.9 **"Drawings"** means the Employer's Drawings and the Drawings submitted by the Contractor and any modification of such drawings as any, from time to time, be furnished or for which the Engineer has issued a Notice of No Objection.
- 1.1.1.10 **"Employer's Requirements"** means the description of the scope, standard, design criteria, specifications, drawings, programme of work, indigenization programme (where applicable) as included in the Contract, and any alterations and modifications thereto in accordance with the Contract.
- 1.1.1.11 **"Interim Payment Schedule"** means the schedule included for each Cost Centre in the Pricing Document and accepted by the Employer to be

GENERAL CONDITIONS OF CONTRACT

used for interim payments in relation to achievement of milestones under that Cost Centre, as the same may be revised from time to time in accordance with Clause 11.

- 1.1.1.12 **"Letter of Acceptance"** means the formal acceptance to work by the Employer of the Tender.
- 1.1.1.13 **"Notice to Proceed"** means the notice issued by the Employer to the Contractor communicating the date on which the Works are to be commenced.
- 1.1.1.14 **"Letter of Tender"** means the document entitled letter of tender, which was completed by the Contractor and includes the signed offer to the Employer for the Works.
- 1.1.1.15 **"Conditions of Contract on Safety & Health and Environment"** means the Employer's manual containing the requirements and conditions to be met during the execution of the Works by the Contractor.
- 1.1.1.16 **"Schedules"** means the information and data submitted with the Tender, as included in the Contract.
- 1.1.1.17 **"Tender"** means the Contractor's priced offer to the Employer for the designing where ever applicable, execution, manufacture, and completion of the whole of Works, testing and commissioning (including Integrated Testing and Commissioning where ever applicable) and remedying of any defects therein, as accepted by the Letter of Acceptance.
- 1.1.1.18 **"Schedule of Milestones"** means the schedule included in each Cost Centre in the Pricing Document, describing the Milestones and stipulating dates by which the Milestones are to be achieved under that Cost Centre in order to maintain interim payments by the Employer to the Contractor in accordance with the Interim Payment Schedule for that Cost Centre, as the same may be revised from time to time in accordance with the Contract.
- 1.1.1.19 **"Schedule of Payment"** means the schedule included in the Bill of Quantity for payment in various stages on part of the works.
- 1.1.1.20 **"Special Conditions of Contract"** means any special conditions of contract issued by the Employer prior to submission of the Tender or negotiated and agreed in writing by the Employer and the Contractor prior to conditional upon acceptance of the Tender.
- 1.1.1.21 **"Works Programme"** means the programme showing the sequence, method and timing of investigations, design, issue of No Objection Notices, execution, manufacture, delivery to site, erection, installation, testing, commissioning of the Works (including Integrated Testing and Commissioning), indigenization (where applicable) and related activities in the form and content prescribed by the Employer's Requirements, or any amended or varied version thereof, as submitted by the Contractor and for which the Engineer has issued a Notice of No Objection.

1.1.2 Persons

- 1.1.2.1 **"Party"** means the Employer or the Contractor as the context requires.
- 1.1.2.2 **"Tenderer or Bidder"** means the person submitting a bid/Tender.
- 1.1.2.3 **"Contractor"** means the person whose Tender has been accepted by the Employer and the legal successors in title to such person, but not

253

GENERAL CONDITIONS OF CONTRACT

(except with the consent of the Employer) any assignee of such person.

- 1.1.2.4 **"Contractor's Representative"** shall mean a person named by the Contractor in the Contract or appointed from time to time by the Contractor under Sub-clause 4.3 to act on behalf of Contractor.
- 1.1.2.5 **"Designated Contractors"** means any of the following whose activities or the works they are engaged to carry out, affect or are affected by the Works, in any way or at any time:
 - a. contractors, design consultants and utility authorities engaged on the Project from time to time by the Employer;
 - b. Sub-contractors of any tier of the contractors above; provided that the definition shall exclude the Contractor and his Sub-contractors of any tier in relation to the Works.
- 1.1.2.6 **"Other Contractor"** means a person employed by or having Contract directly or indirectly with the Employer otherwise than through the Contractor.
- 1.1.2.7 **"Designer"** means the Contractor, or part of the group forming the contractor, person, firm or company or group of companies, or any replacement, carrying out the Design of Works or part thereof.
- 1.1.2.8 **"Employer"** means NOIDA METRO RAIL CORPORATION LIMITED (NMRC), its legal successors and assignees.
- 1.1.2.9 **"Engineer"** means any person nominated or appointed from time to time by the Employer to act as the Engineer for the purposes of the Contract and notified as such in writing to the Contractor.
- 1.1.2.10 **"Engineer's Representative"** means any Assistant of the Engineer appointed from time to time by the Engineer under Sub-clause 3.3
- 1.1.2.11 **"Sub-contractor"** means any person named in the Contract as a sub-contractor, manufacturer or supplier for a part of the Works or any person to whom a part of the Works has been sub-contracted with the consent of the Employer and the legal successors in title to such person, but not any assignee of such person.
- 1.1.3 **Dates, Times and Periods**
 - 1.1.3.1 **"Commencement Date"** means the date on which the Contractor shall commence the Works on the written instructions of the Employer contained in the Notice to Proceed.
 - 1.1.3.2 **"Contract Period"** means the period from the Commencement Date to the end of Defects Liability Period including Integrated Testing and Commissioning and as certified by the Engineer under Clause 7.11 (or as extended under Sub-clause 10.3).
 - 1.1.3.3 **"Day"** means a calendar day, **"Week"** means 7 calendar days, **"Month"** means a calendar month and **"Year"** means 365 days.
 - 1.1.3.4 **"Effective Date"** means the date on which the Contract comes into force and effect.
 - 1.1.3.5 **"Gazetted Holiday"** means every holiday which is observed by NOIDA METRO Rail Corporation Limited as a gazetted holiday as well as a weekly holiday.
 - 1.1.3.6 **"General Holiday"** means Sunday.

GENERAL CONDITIONS OF CONTRACT

- 1.1.3.7 **"Key Date"** means a date identified as such in the Contract.
- 1.1.3.8 **"Milestone"** means the completion of a part of the Works or the occurrence of an event identified as such in the Schedule of Milestones.
- 1.1.3.9 **"Milestone Date"** means the date prescribed in the Schedule of Milestone by which a Milestone is to be achieved, if Interim Payments for the Cost Centre in which the Milestone is included are not to be suspended.
- 1.1.3.10 **"Stage"** means level of progress of the works identified as such and more particularly described in the Employer's Requirements for which a Key Date for the achievement thereof is stipulated in the Contract.
- 1.1.3.11 **"Time for Completion"** means the time for completing the Works or a section or a part thereof (as the case may be), and passing the Tests on Completion, including Integrated Testing and Commissioning, as stated in the contract, calculated from the Commencement Date.
- 1.1.4 Tests and Completion**
 - 1.1.4.1 **"Factory Tests"** means the tests required to be carried out in the factory premises on components, equipment, subsystem, system, etc. during and/or after manufacture in the factory.
 - 1.1.4.2 **"Integrated Testing"** in the contracts where applicable means the programme of tests performed by the Contractor at the direction of the Engineer following satisfactory completion of Contractor's tests on his equipment, sub-systems or system to verify and confirm the compatibility and compliant performance of his equipment/ sub-system/ system with the equipment/ sub-system/ system provided by others.
 - 1.1.4.3 **"Milestone Certificate"** means the certificate to be issued by the Engineer in relation to the achievement or otherwise of Milestones.
 - 1.1.4.4 **"Performance Certificate"** means the certificate issued by the Engineer under Sub-clause 10.9.
 - 1.1.4.5 **"Taking Over Certificate"** means a certificate issued under Clause 9.1.
 - 1.1.4.6 **"Tests on Completion"** means the tests specified in the Contract and designated as such, including Integrated Testing where applicable and any other such tests as may be agreed by the Engineer and the Contractor, or instructed as a Variation, which are to be carried out before the Works, or any Section are taken over by the Employer.
- 1.1.5 Money and Payments**
 - 1.1.5.1 **"Contract Price"** means the sum stated in the Letter of Acceptance as payable to the Contractor, subject to such additions thereto or deductions therefrom as may be made under the provisions of the Contract.
 - 1.1.5.2 **"Cost"** means all expenditure properly incurred (or to be incurred) by the Contractor, whether on or off the Site,
 - 1.1.5.3 **"Cost Centre Amount"** means the amount apportioned to a Cost Centre as set out in the Pricing Document, as the same may be revised from time to time in accordance with the Contract.
 - 1.1.5.4 **"Final Payment Certificate"** means the payment certificate issued by the Engineer under Sub-clause 11.9.

251

GENERAL CONDITIONS OF CONTRACT

- 1.1.5.5 **"Final Statement"** means the agreed statement defined in Sub-clause 11.10.
- 1.1.5.6 **"Foreign Currency"** means a freely convertible international trading currency in which part of the Contract Price is payable, but not the Local Currency.
- 1.1.5.7 **"Interim Payment Certificate"** means any payment certificate issued by the Engineer under Sub-clause 11.5, other than the Final Payment Certificate.
- 1.1.5.8 **"Local Currency"** means Indian Rupees (INR).
- 1.1.6 Other Definitions**
- 1.1.6.1 **"Approval or Approved"** means Approval in writing including subsequent written confirmation of previous verbal approval.
- 1.1.6.2 **"Contractor's Equipment"** means all machinery, apparatus, appliances, other things of whatsoever nature required for purpose of the Contract, including without limitation, Contractor's Plant and Equipment, or Materials to or from the Site, but does not include Plant, or Materials intended to form or forming part of the Permanent Works.
- 1.1.6.3 **"Cost Centre"** means a group of activities and/ or items of work identified as such in the Pricing Document.
- 1.1.6.4 **"Materials"** means things of all kinds (other than Plant) to be provided and incorporated in the Permanent Works by the Contractor, including the supply-only items (if any), which are to be supplied by the Contractor as specified in the Contract.
- 1.1.6.5 **"Plant"** means the machinery, equipment, and apparatus and the likes, intended to form or forming part of the Permanent Works, including the supply-only items (if any), which are to be supplied by the Contractor as specified in the Contract.
- 1.1.6.6 **"Section"** means a part of the Works specifically designated in the Appendix to Form of Tender as a Section (if any)
- 1.1.6.7 **"Site"** means the places provided by the Employer where the Works are to be executed and to which Plant, Rolling Stock and Materials are to be delivered and any other place as may be specifically designated in the Contract as forming part of the Site. Site includes Depot, where Rolling Stock will be delivered, tested and commissioned as provided in the Contract.
- 1.1.6.8 **"Scheduled Bank"** means a bank included in the second schedule to the Reserve Bank of India Act, 1934, or modifications thereto.
- 1.1.6.9 **"Specification"** means the Specification referred to in the contract and any modification thereof or addition thereto, as may from time to time be furnished or approved in writing by the Engineer.
- 1.1.6.10 **"Test"** means such Tests as are prescribed in the Specifications or by the Engineer or Engineer's Representative, whether performed by the Contractor or by the Engineer or his Representative or any agency acting under the direction of the Engineer.
- 1.1.6.11 **"Variation"** means any alteration and/ or modification to the Employer's Requirements, which is instructed by the Engineer or approved as a variation by the Engineer, in accordance with Clause 12.
- 1.1.6.12 **"Works"** means the work, both permanent and temporary, or services to

GENERAL CONDITIONS OF CONTRACT

be carried out, designed, manufactured, fabricated, delivered to Site, erected, installed, completed, tested, commissioned, (including Integrated Testing and Commissioning) and remedying of any defects, and/ or supplied in accordance with the Contract and include Plant, Rolling Stock and Materials and their accessories.

- 1.1.6.13 **"Permanent Works"** means the permanent works to be designed and executed in accordance with the Contract.
- 1.1.6.14 **"Temporary Works"** means all temporary works of every kind (other than Contractor's Equipment) required for the execution and completion of the Works, and the remedying of any defects.
- 1.1.6.15 **"Project"** means Noida-Greater Noida Mass Rapid Transport System (MRTS),

Interpretation

- 1.2 In the Contract except where the context requires otherwise:
 - 1.2.1 a. words indicating one gender include all genders;
 - b. words indicating the singular also include the plural and words indicating the plural also include the singular and
 - c. "written" or " in writing" means hand-written, type written, printed or electronically made and resulting in a permanent record.

The marginal words and other headings shall not be taken into consideration in the interpretation of these conditions.

- 1.2.2 Terms and expressions not herein defined" shall have the meanings assigned to them in the "Indian General Clauses Act, 1897" or the Indian Contract Act or the Indian Sale of Goods Act or any other applicable Indian Law, as the case may be.

Law and Language

- 1.3 The Contract shall be governed by the Acts and Laws of India, the rules, regulations and bye-laws of the concerned public bodies and authorities. Language of the Contract shall be English.

Contract Agreement

- 1.4 The Employer and the Contractor shall execute a Contract Agreement, with such modifications as may be necessary to record the Contract. The costs of stamp duties and similar charges imposed by law shall be borne by the Contractor.

Priority of Documents

- 1.5 The documents forming the Contract are to be taken as mutually explanatory of one another. If there is an ambiguity or discrepancy or inconsistency in the documents, the Engineer shall issue any necessary clarification or instruction to the Contractor, and the priority of the documents shall be as follows:
 - a. The Contract Agreement;
 - b. The Letter of Acceptance;
 - c. Pre and Post bid proceeds
 - d. Form of Tender
 - e. BOQ/Payment schedule
 - f. NIT
 - g. ITT
 - h. The Outline Design Specifications (Design Criteria) and Outline

24

GENERAL CONDITIONS OF CONTRACT

- Construction Specifications; or any other specification
- i. Drawings
- j. The Employer's Requirements
- k. The Special Conditions of Contract;
- l. The General Conditions of Contract;
- m. The Contractor's Proposal; and
- n. Any other document forming part of the Contract.

Care and Supply of Construction and/or Manufacture Documents 1.6

The Construction and/or Manufacture Documents shall be in the custody and care of the Contractor during the Contract. Unless otherwise stated in the Employer's Requirements, the Contractor shall provide three copies for the use of the Engineer and Assistants (as referred to in Sub-clause 5.3).

The Contractor shall keep, on the Site, one complete set of the documents forming the Contract, the Construction and/or Manufacture Documents, Variations, other communications given or issued from time to time and the documents/samples mentioned in Sub-clause 5.3. The Employer, the Engineer and their Assistants (as referred to in Sub-clause 3.3) shall have the right to access these documents at all reasonable times.

On discovery of any technical error or defect in a document intended to be used for the purpose of Contract, the Contractor shall promptly give notice to the Engineer of such error or defect.

Communications 1.7

Communications between parties, unless otherwise specified shall be effective only when made in writing. A notice will be effective only when delivered sent to the address of the Party by registered post or by telex or telefax or by an e-mail to the email ID of the Party or delivered by hand to the Party.

Employer's Use of Contractor's Documents 1.8

As between the Parties, the Contractor shall retain the copyright and other intellectual property rights in the Contractor's Documents and other design documents made by (or on behalf of) the Contractor.

The Contractor shall be deemed (by signing the Contract) to give to the Employer a non-terminable, transferable, non-exclusive royalty-free licence to copy, use and communicate the Contractor's Documents, including making and using modifications of them. This licence shall:

- a. apply throughout the actual or intended working life (whichever is longer) of the relevant parts of the Works,
- b. entitle any person in proper possession of the relevant part of the Works to copy, use and communicate the Contractor's Documents for the purposes of completing, operating, maintaining, altering, adjusting, repairing and demolishing the Works, and
- c. in the case of Contractor's Documents which are in the form of computer programs and other software, permit their use on any computer on the Site and other places as envisaged by the Contract, including replacements of any computers supplied by the Contractor.

After payment of the consideration under the Contract to the Contractor all the intellectual property rights of Contractor vested in the Works, executed under the Contract, should get transferred and vested in the Employer.

[Handwritten signatures and initials in blue ink]

GENERAL CONDITIONS OF CONTRACT

Contractor's Use of Employer's Documents 1.9 As between the Parties, the Employer shall retain the copyright and other intellectual property rights in the Employer's Requirements and other documents made by (or on behalf of) the Employer. The Contractor may, at his cost, copy, use, and obtain communication of these documents for the purposes of the Contract.

They shall not, without the Employer's consent, be copied, used or communicated to a third party by the Contractor, except as necessary for the purposes of the Contract.

Compliance with Statutes, Regulations and Laws 1.10 The Contractor shall familiarise themselves and conform in all aspects with:

- a. the provision of any enactment in India as applicable from time to time
- b. the regulations or bye-laws of any local body and utilities.
- c. The Contractor shall be bound to give all notices required by statute, regulations or bye-laws, as aforesaid and to pay all fees and bills payable in respect thereof. The Contractor will arrange necessary clearances and approvals before the Work is taken up.

Ignorance of Rules, Regulations and Bye-laws shall not constitute a basis for any claim at any stage of work.

The Contractor shall indemnify the Employer against all penalties and liabilities of every kind of breach of any such enactment, laws, regulations, bye-laws or rules.

Joint and Several Liability 1.11 If the Contractor is (under applicable Laws) a joint venture, consortium, or other incorporated or unincorporated grouping of two or more Persons:

- a. these Persons shall be deemed to be jointly and severally liable to the Employer for the performance of the Contract;
- b. these Persons shall notify the Employer of their leader who shall have authority to bind the Contractor and each of these persons; and
- c. the Contractor shall not alter its composition or legal status without the prior consent of the Employer.

2 THE EMPLOYER

General Obligations 2.1 The Employer shall provide the Site/area of works and shall pay the Contractor in accordance with the Contract.

Access to and Possession of the Site 2.2 The Employer shall grant the Contractor right of access to, and / or possession of, the Site progressively for the completion of Works. Such right and possession may not be exclusive to the Contractor. The Contractor will draw/modify the schedule for completion of Works according to progressive possession/right of such sites.

If the Contractor suffers delay from failure on the part of the Employer to grant right of access to, or possession of the Site, the Contractor shall give notice to the Engineer in a period of 28 days of such occurrence. After receipt of such notice, the Engineer shall proceed to determine any extension of time to which the Contractor is entitled and shall notify the Contractor accordingly.

For any such delay in handing over of site, Contractors will be entitled to

2047
GENERAL CONDITIONS OF CONTRACT

- only reasonable extension of time and no monetary claims, whatsoever shall be paid or entertained on this account.
- Permits, Licences or Approvals** 2.3 It shall be Contractor's exclusive responsibility to get approvals, permits or license required for the Contract. However, the Employer may (where he is in a position to do so) provide reasonable assistance to Contractor at the request and cost of the Contractor in getting Permits, License or Approvals required during the Contract.
- The rendering of such assistance by the Employer shall not be interpreted as a pretext by the Contractor as condoning of any delay or non-performance of any of the Contractors obligations. The following-up of all such applications shall be the responsibility of the Contractor.
- Assignment by the Employer** 2.4 The Employer shall be fully entitled without the consent of the Contractor, to assign the benefit of the part thereof and any interest therein or thereunder to any third Party.

3 **THE ENGINEER**

- Appointment of Engineer** 3.1 The Employer shall notify the Contractor in writing of the appointment and identity of the Engineer and of any replacement from time to time, in absence of any written communication from the Employer about the appointment/identity/replacement of the Engineer, the Chief Project Manager/HOD of the Employer, in charge of the Works being executed by the Contractor, would be the Engineer under the Contract..
- Duties and Authorities of the Engineer** 3.2 The Engineer shall carry out the duties specified in the Contract. The Engineer shall have no authority to amend the Contract.
- The Engineer may exercise the authority specified in, or necessarily to be implied from the Contract. If the Engineer is required to obtain the specific approval of the Employer before exercising such authority, such requirements shall be as stated in Special Conditions of Contract. Any requisite approval shall be deemed to have been given by the Employer for any such authority exercised by the Engineer.
- The Engineer shall have no authority to relieve the Contractor of any of his duties, obligations, or responsibilities under the Contract. Any proposal, inspection, examination, testing, consent, approval or similar act by the Engineer (including absence of disapproval) shall not relieve the Contractor from any responsibility, including responsibility for his errors, omissions, discrepancies, and non-compliance with Sub-clause 5.4.
- The Engineer shall copy to the Employer all communications given or received by him in accordance with the Contract.
- Engineer's Authority to Delegate** 3.3 (i) The Engineer may from time to time assign and delegate authority to Engineer's Representatives/Assistants and may also revoke such assignments and delegations. The delegation or revocation shall be in writing and shall be applicable only after same has been notified in writing to the Contractor.
- (ii) Each Assistant to whom duties have been assigned or authority has

GENERAL CONDITIONS OF CONTRACT

been delegated shall be authorized to issue instructions to the Contractor to the extent defined by the delegation. Any determination, approval, check, certificate, consent, examination, inspection, instruction, notice, proposal, request, test or similar act by an Assistant shall have the same effect as though the act had been an act of the Engineer. However:

- a. Any failure to disapprove any Plant, Goods, Material, Design and Workmanship shall not prejudice the right of the Engineer to reject such Plant, Goods, Material, Design and Workmanship;
- b. if the Contractor questions any determination or instruction of an Assistant of the Engineer, the Contractor may refer the matter to the Engineer within three days of such decision having been given, who shall confirm, reverse or vary such determination or instruction.

Engineer's Instructions

3.4

The Contractor shall comply with instructions given by the Engineer in accordance with the Contract.

The Contractor shall give reasonable notice to the Engineer of any instruction, which he considers necessary for the execution of the Works, to enable the Engineer to issue the instruction so that progress of the Works is not delayed. The Engineer shall not, however, be bound to issue any instruction which, in his opinion, is unnecessary.

No act or omission by the Engineer or the Assistants to the Engineer in the performance of any of the Engineer's duties or the exercise of any of the Engineer's powers under the Contract shall, in any way, operate to relieve the Contractor of any of the duties, responsibilities, obligations or liabilities imposed upon the Contractor by any of the provisions of the Contract.

Engineer to Attempt Agreement

3.5

When the Engineer is required to determine value, cost or extension of time, he shall consult with the Contractor and the Employer in an endeavour to reach agreement. If agreement is not achieved, the Engineer shall determine the matter fairly, reasonably and in accordance with the Contract, with the approval of Employer.

4

THE CONTRACTOR

General Obligations

4.1

The Works as completed by the Contractor shall be wholly in accordance with the Contract and fit for the purposes for which they are intended, as defined in the Contract. The Works shall include any work which is necessary to satisfy the Employer's Requirements, the Contractor's Proposal and Schedules, or is implied by the Contract, or arises from any obligation of the Contractor, and all works not mentioned in the Contract but which may be inferred to be necessary for stability, or completion, or the safe, reliable and efficient operation of the Works.

The Contractor shall design, if in the scope of work, manufacture, execute, install, complete, test (including Integrated Testing in case of rolling stock and signalling contracts) and commission, the Works, including providing Construction and/or Manufacture Documents, within the Time for Completion and shall remedy any defects within the Contract Period. The Contractor shall provide all superintendence, labour, Plant, Materials, Contractor's Equipment, Temporary Works and

245

GENERAL CONDITIONS OF CONTRACT

all other things, whether of a temporary or permanent nature, required in and for such design, works and remedying of defects.

Before commencing design, if in the scope of the Contract, the Contractor shall satisfy himself regarding the Employer's Requirements (including design criteria and calculations, if any) and the items of reference mentioned in Sub-clause 4.8.

The Contractor shall give notice to the Engineer of any error, fault or other defect in the Employer's Requirements or such items of reference. After receipt of such notice, the Engineer shall determine whether Clause 12 shall be applied, and shall notify the Contractor accordingly.

The Contractor shall take full responsibility for the adequacy, stability and safety of all Site operations, of all methods of construction, manufacture, and of all the Works, irrespective of any approval or consent by the Engineer.

The Contractor shall be deemed to have satisfied himself before submitting his Tender as to the correctness and sufficiency of his Tender to cover all his risks, liabilities and obligations set out in or implied by the Contract and all matters and things necessary for the proper design, manufacture, execution, installation, completion, testing, Integrated Testing whichever is in the scope of the Contract, commissioning of the Works and remedying of the Defects.

The Contractor acknowledges responsibility for ascertaining and securing at his own cost:

- a. conditions bearing upon the proper transportation, disposal, handling and storage of materials (including but not limited to hazardous toxic substances and excavated materials);
- b. availability of electricity, water and gas;
- c. availability of skilled manpower;
- d. the character of equipment and facilities needed preliminary to and during the manufacture, installation, execution, testing, Integrated Testing, and commissioning of the Works and remedying of any defects;
- e. the protection of the environment and adjacent structures which will be necessary preliminary to and during the manufacture, installation, execution, testing, Integrated Testing, and commissioning of the Works and remedying of any defects;
- f. the location of and the authorization required for and the means of diversion of any services and facilities required for the purposes of the Works.

The Contractor shall whenever required by the Engineer, submit details of the arrangement and methods which the Contractor proposed to adopt for the execution of the Works. No alteration to these arrangements or methods shall be made without the approval of the Engineer.

Performance Security Amount 4.2

4.2.1 Within 30 days from date of issue of the Letter of Acceptance, the successful Tenderer shall furnish Performance Security, for an amount of ten per cent of the Contract value in types and proportions of currencies in which the Contract Price is payable either in the form of a Bank Draft, FDR or in the form of a Bank Guarantee from a branch in India of a scheduled foreign bank or from a scheduled commercial bank in India

GENERAL CONDITIONS OF CONTRACT

acceptable to the Employer. The Extension of time for submission of Performance Security beyond 30 (Thirty) days up to 60 days from date of issue of LOA may be given by the Authority who is competent to sign the Contract Agreement. However, a Penal Interest of 15% per annum shall be charged for the entire period i.e. from the date of issue of LOA to the date of submission of Performance Security. In case the Contractor fails to submit the requisite Performance Security within 60 days from the date of issue of LOA, the Contract shall be annulled duly forfeiting Tender Security and other dues, if any payable against the Contract. The failed Contractor shall be debarred not only from participating in re-tender for that work but also in any other tender of NMRC for a period of one year from date of issue of LOA. The approved form provided in the "Instructions to Tenderers" shall be used for Bank Guarantee.

The successful Tenderer shall have the following options for submission of Performance Security;

(i) Performance Security for an amount of 10% of Contract value, if the same is in the form of Bank Guarantee/FDR, it shall be valid up to 6 months beyond the Defect Liability Period, or

(ii) Performance Security in the form of two Bank Guarantees/FDRs, each for an amount of 5% of Contract Value with one Bank Guarantee/FDR valid up to 6 months beyond the date of completion of work and second Bank Guarantee/FDR valid up to 6 months beyond the Defect Liability Period, or

(iii) One part of Performance Security for an amount of 5% of Contract value, if the same is in the form of Bank Guarantee/FDR, it shall be valid up to 6 months beyond the Defect Liability Period. For 2nd part of Performance Security for an amount of 5% of Contract value, amount shall be deducted at the rate of 5% of the gross amount of each running on-account bill. The Performance Security so deducted from running on-account bill, shall be released on completion of entire work in terms of Clause 4.2.3(i) of GCC. After achieving every 25% of financial progress w.r.t. Original Contract Value, Contractor can ask for release of such amount deducted towards Performance Security on submission of Bank Guarantee/FDR for an equal amount with validity up to 6 months beyond the date of completion of work. The Contractor shall always have the option during the currency of Contract to submit 2nd part of Performance Security for an amount of 5% of Contract value in the form of Bank Guarantee/FDR with validity up to 6 months beyond the date of completion of work. In such a case, further deduction of Performance Security amount from running on-account bill shall be stopped and the amount deducted towards Performance Security shall be released.

In case, if Contract is terminated due to Contractor's default in terms of GCC Clause 13.2, the full 10% Performance Security amount shall be forfeited. Shortfall amount, if any, shall be recovered by the Employer from monies due to the Contractor under the Contract including, without limitation, and the Employer shall have the power to recover any balance from monies due to the Contractor under any other Contract between the Employer and the Contractor.

In case the Contract value exceeds beyond 25% of the Original Contract Value, the Contractor shall have to submit additional Performance Security as follows:

If variation amount on plus side exceeds 25% of the Original Contract Value either due to Employer's variation or due to Contractor's variation,

2013

GENERAL CONDITIONS OF CONTRACT

the Contractor shall submit additional performance security equal to an amount of 10% of the variation amount exceeding 25% of the Original Contract Value.

No additional Performance Security will be required to be submitted if the variation amount on plus side is within 25% of the Original Contract Value.

Forfeiture 4.2.2

Failure of the successful Tenderer to furnish the required Performance Security shall be a ground for the annulment of the award of Contract and forfeiture of the Tender Security.

The whole of the Performance Security amount shall be liable to be forfeited by the Employer at the discretion of the Employer, in the event of any breach of contract on the part of the Contractor. The forfeiture of the Performance Security amount by the Employer would be without prejudice to any amount(s) of money that the Employer may recover as Liquidated Damages or any other damages from the Contractor. The forfeiture of Performance Security amount by the Employer, would not operate as bar/set off/ adjustment from any amount of money which becomes recoverable or is recovered by the Employer. In case of the Performance Security Amount Bank Guarantee being invoked and forfeited by the Employer, the Contractor would immediately replenish the amount of Performance Security Bank Guarantee.

Release 4.2.3

- i. On completion of the entire Work/part Work, one half of the proportionate Performance Security shall be refunded to the Contractor, on issue of Taking Over Certificate/part Taking Over Certificate by the Engineer, in accordance with Sub-clause 9.1 and 9.2 of these conditions. The above shall not relieve the Contractor from his obligations and liabilities, to make good the defects that may be detected during the Defect Liability Period
- ii. The balance amount shall become due and shall be paid to the Contractor on signing of the Performance Certificate after the expiry of the final Defect Liability Period as per Clause 10.9 of these conditions.

Guarantees and Warranties 4.2.4

Within 30 days of the date of Letter of Acceptance of the Tender, the Contractor shall submit to the Employer:

- i. An Undertaking in the approved format from a Parent Company, the identity of which shall have been submitted in writing to the Employer prior to acceptance of the Tender and against which the Employer shall have raised no objection.
- ii. A written Guarantee in the approved format from a Parent Company, the identity of which shall have been submitted in writing to the Employer prior to acceptance of the Tender and against which the Employer shall have raised no objection.
- iii. A warrantee in the approved format from the Contractor.

In the event that the Contractor shall comprise two or more members, corporations acting in partnership, joint venture, consortium or otherwise each such member or corporation shall submit a Parent Company Undertaking and Guarantee.

Notwithstanding any other provision of the Contract:

- a. submission by the Contractor of the requisite Performance security, Parent Company Undertakings and written Guarantees shall be condition precedent to the Contractor's entitlement to any payment,

GENERAL CONDITIONS OF CONTRACT

under the Contract; and

b. failure by the Contractor to provide a Performance Security or Parent Company Undertakings or Parent Company Guarantees shall entitle the Employer either to suspend the Works or to terminate the Contract forthwith by notice in writing to that effect, notwithstanding that the Contractor may have been permitted to proceed with the Works, and the Contractor shall not be entitled to any compensation whatsoever as a consequence of such suspension or termination.

Representation on Works 4.3

Unless the Contractor's Representative is named in the Contract, the Contractor shall, within 14 days of Notice to Proceed, submit to the Engineer for consent the name and particulars of the person the Contractor proposes to appoint. The Contractor shall not revoke the appointment of the Contractor's Representative without the prior consent of the Engineer. The Contractor's Representative so nominated shall have full authority to act on behalf of the Contractor. The Contractor's Representative shall give his whole time to directing the preparation of the Construction and/or Manufacture Documents and the execution of the Works. The Contractor's Representative shall receive (on behalf of the Contractor) all notices, instructions, consents, no objection certificate, approvals, certificates, determinations and other communications under the Contract. Whenever the Contractor's Representative is to be absent from the Site, a suitable replacement person shall be appointed, with prior consent of Engineer.

Failure on part of the Contractor to comply with these provisions shall constitute a breach of Contract leading to action under Sub-clause 13.2.

The Contractor's Representative may delegate any of his powers, functions and authorities to any competent person, and may at any time revoke any such delegation. Any such delegation or revocation shall be in writing and shall not take effect until the Engineer has given prior consent thereto. The Contractor's Representative and such persons shall be fluent in the language of day to day communication and the Contractor shall be bound by and fully liable for the acts or omissions of the Contractor's Representatives or any of his employees and/or delegates, agents or nominees.

Facilities for and co-ordination with Others. 4.4

The Contractor shall not impede and shall afford all necessary facilities, access and/or services to the Employer, Engineer, Designated Contractors, utility undertakings, other relevant authorities and other Contractors (whether employed by the Employer or not) who are carrying out on, or in the vicinity of, the Site, Works not included in the Contract but forming part of the Project:

a. The Contractor shall take all reasonable steps to ensure that the Works are co-ordinated and integrated with the design, manufacture, installation execution and testing of such other Works and shall in particular (but without limitation):

i. comply with any direction which the Engineer may give for the integration of the design of the Works with the design of any other part of the Project;

ii. consult, liaise and co-operate with those responsible for carrying out such other Works, including where necessary, in the preparation of the respective designs, the preparation of co-ordinated programmes, method statements, co-ordination drawings and specifications together

[Handwritten signature]

[Handwritten signature]

[Handwritten mark]

241

GENERAL CONDITIONS OF CONTRACT

with arrangements of service priorities and zoning;

- iii. participate in Integrated Testing and Commissioning of the system with Designated Contractors and demonstrate to the satisfaction of the Engineer that the Works have been designed and constructed in a manner compatible with the Works of Designated Contractors.
- b. The Contractor shall undertake design co-ordination with other Contractors who are carrying out Works forming part of the Project as described in the Employer's Requirements. At the end of each such co-ordination period, the Contractor and the other Contractor with whose Works the interface period refers shall jointly state in writing that their design co-ordination activities are complete and that their respective designs are integrated and can be finalised without interference with each other's designs or the designs with which their designs have already been integrated. A copy of this joint written statement shall be provided to the Engineer within 7 days of the end of the said design co-ordination period. Unless and until copies of all relevant and necessary design co-ordination statements have been submitted to the Engineer, the Engineer shall be entitled to suspend any review or further review of the Contractor's or the other Contractor's design submissions. Such suspension shall not be grounds for the Contractor to claim nor shall be entitled to receive an extension of time or additional payments.
- c. The Contractor shall provide within the Site, staging, storage and unloading areas for the use of Designated Contractors, if any, who are undertaking trackwork, fare collection system, supply, testing and commissioning of Rolling Stock, escalators, lifts, signalling and telecommunications and traction power installation Works, etc. Separate locations shall be provided for each such Contractor. The exact size and location of these staging, storage and unloading areas, and the commencement date shall be co-ordinated and agreed during the design interface period with each Designated Contractor.
- d. Any other contract which depends for its execution on the Contract or upon which the Contract is dependent for its own execution shall be identified by the Engineer as a "Designated Contract". The Contractor shall provide attendance on Designated Contractors in accordance with the Employer's Requirements and as Instructed by the Engineer. The identity of the Contractor for a Designated Contract may not be known before the execution of the Contract but this shall not be a ground for the Contractor to object to the subsequent appointment of a Designated Contractor.
- e. The Contractor shall in accordance with the requirements of the Engineer co-ordinate his own Works with that of Designated Contractors through Co-ordinated Installation Programme (CIP) stated in the Employer's Requirements, or as the Engineer may require, and shall afford the Designated Contractors all reasonable opportunities for carrying out their Works.
- f. The Contractor shall afford all reasonable opportunities, for carrying out their Work, to other Contractors employed by the Employer and their workmen respectively and the workmen of the Employer who may be engaged on or near the Site of any Work, ancillary to the Works, but, not included in the Contract and shall not cause them

L

Handwritten signature

240

GENERAL CONDITIONS OF CONTRACT

inconvenience.

g. If the Contractor suffer delay by reasons of failure by any Designated Contractor to meet the specified installation interfacing and co-ordination, completion dates and if such delay has been caused otherwise than the fault of the Contractor, or, if compliance with Sub-clause (f) herein shall involve the Contractor in delay beyond that which could be reasonably foreseen by an experienced Contractor at the time of Tender, then the Engineer shall take such delay into account in determining any extension of time to which the Contractor is entitled under the Contract.

h. It shall be the responsibility of the Contractor to ensure that the full extent of the Works under the Contract and the Works to be carried out by Designated Contractors within the Works or, in, on, under, through and over the Site are co-ordinated and integrated in their design, manufacture, installation and construction. Such responsibility shall neither be mitigated nor in any other way affected by virtue of similar responsibilities being placed on other Contractors.

The Contractor shall be deemed to have made adequate allowance in the Contract Price and in the Works Programme in respect of these obligations.

If any act or omission of the Contractor whether directly or indirectly results in the delay in the execution of the Works of a Designated Contractor, the Contractor, in addition to his liability in respect of Liquidated Damages if they become due, shall pay to the Employer, or the Engineer may deduct from Interim Payment Certificates such amount as the Engineer shall have certified in respect of additional payments or costs to the Designated Contractor in respect of such delay.

Sub-contractors 4.5

4.5.1 The Contractor shall not sub-contract the whole of the Works.

4.5.2 Unless otherwise stated in the Special Conditions of Contract:

a. the Contractor shall not be required to obtain consent for purchases of Materials which are in accordance with the makes specified in the Contract or provisions of labour or for the sub-contracts for which the Sub-contractor is named in the Contract;

b. the prior consent of the Engineer shall be obtained for other proposed Sub-contractors;

c. not less than 28 days before the intended date of each Sub-contractor commencing work, the Contractor shall notify the Engineer of such intention; and the Contractor shall give fair and reasonable opportunity for Contractors in India to be appointed as Sub-contractors.

4.5.3 The Contractor shall be responsible for observance by all Sub-contractors of all the provisions of the Contract. The Contractor shall be responsible for the acts or defaults of any Sub-contractor, his representatives or employees, as fully as if they were the acts or defaults of the Contractor, his representatives or employees and nothing contained in Sub-clause (a) of clause 4.5 shall constitute a waiver of the Contractor's obligations under this Contract. The Contractor shall provide to the Engineer of all the Sub-contracts including terms, conditions and pricing. The Contractor shall endeavour to resolve all matters and payments amicably and speedily with the Sub-contractors.

239

GENERAL CONDITIONS OF CONTRACT

4.5.4 The Contractor shall ensure that their Sub-contractors, material/equipment Suppliers, Consultants and other Agencies deployed by them in connection with execution of the Contract do not make any claim or raise any dispute before NMRC. For this, necessary provision is to be made in the agreement between Contractor and their Sub-contractors/Consultants/other Agencies. Similarly the agreement should also incorporate the provision of dispute resolution. An undertaking in the following format shall be submitted by Contractor in respect of each such agency:-

"Name of Work.....

In connection with above Work, M/s....., Contractor has/is engaging M/s....., as Sub-contractor(or Consultant or material/equipment Supplier or Service provider). For this, the terms and conditions of agreement include necessary provisions for resolution of dispute if any arising between Contractor and Sub-contractor.

It is confirmed by the Sub-contractor that any claim/dispute arising out of the above Work shall be resolved in terms of agreement and shall not be raised before NMRC and also shall not make any claim against NMRC before any forum/court.

Signature of Contractor

Assignment of Contractor's and Sub-contractor's Obligations

4.6 The Contractor shall not assign a right or benefit under the Contract without first obtaining Employer's prior written consent, otherwise than by :

charge in favour of the Contractor's bankers of any money due or to become due under the Contract.

If a Sub-contractor's obligations extend beyond the expiry date of Defects Liability Period then the Contractor shall assign the benefits of such obligations to the Employer.

In the event that a Sub-contractor of any tier provides to the Contractor or any other Sub-contractor a warranty in respect of Plant, Materials or Services supplied in connection with the Works, or undertakes a continuing obligation of any nature whatsoever in relation to such Plant, Materials or Services (including without limitation an obligation to maintain stocks of spare parts) extending for a period exceeding that of the Defects Liability Period or where there is more than one Defects Liability Period exceeding that of the latest Defects Liability Period, and if the Engineer so directs in writing within 21 days of the expiry of the Defects Liability Period or the latest Defects Liability Period (as the case may be), the Contractor shall immediately assign or obtain the assignment of the benefit of such warranty or obligation to the Employer or at the direction of the Employer, to any third Party referred to in Sub-Clause 2.4.

Compensation for Breach

4.7 Any breach of Sub-clauses 4.5 to 4.6 shall entitle the Employer to rescind the Contract under Clause 13.2 of these conditions and also render the Contractor liable for loss or damage arising due to such cancellation.

Setting Out

4.8

Accurate Setting Out

4.8.1 The Contractor shall be responsible for
a. the accurate setting out of the Works in relation to the original

GENERAL CONDITIONS OF CONTRACT

- points, lines and levels of reference given by the Engineer in writing
- b. the correctness of position, levels, dimensions and alignments of all parts of the Works
- c. the provisions of all necessary instruments, equipment, apparatus and labour in connection with the foregoing responsibilities
- d. Carefully protecting and preserving all bench marks, sight-rails, pegs and other things used in setting out the Works

The checking of any setting-out or of any line or level by the Engineer shall not in any way relieve the Contractor of his responsibility for the accuracy or correctness thereof and the Contractor shall carefully protect and preserve all bench-marks, sight-rails, pegs and other things used in setting out the Works.

Errors in Setting out 4.8.2

If at any time during the execution of the Work, an error appears in the positions, levels, dimensions or alignment of any part of the Works, the Contractor on being required to do so by the Engineer shall, at Contractor's cost, rectify such error to the satisfaction of the Engineer.

Site Data 4.9

- i. The Employer shall have made available to the Contractor with the Tender documents such relevant data in Employer's possession on hydrological and sub-surface conditions. The accuracy or reliability of the data/studies/reports and of any other information supplied at any time by the Employer or Engineer is not warranted including with respect to the viability of his design and execution of Works and the Contractor shall be responsible for interpreting validity, and interpretation of all such data. The Contractor shall conduct further investigations considered necessary by him at his own cost and any error, discrepancies if found in Employer's data at any stage will not constitute ground for any claim for extra time, damages and costs.
- ii. The Contractor shall be deemed to have obtained all necessary information as to risks, contingencies and other circumstances which may influence or affect the Tender or Works.
- iii. The Contractor shall also be deemed to have inspected and examined the Site, its surroundings, the above data and other available information including with respect to the viability of his design and execution of Works and to have satisfied himself before submitting the Tender, as to all the relevant matters including without limitation:
 - a. the form and nature of the Site, including the sub-surface conditions; the hydrological and climatic conditions;
 - b. the extent and nature of the Work, Plant, and Materials necessary for the execution and completion of the Works and the remedying of any defects;
 - c. the applicable laws, procedures and labour practices
 - d. The Contractor's requirement for access, accommodation, facilities, personnel, power, transport and other services.
 - e. the risk of injury or damage to property adjacent to the Site and to the occupiers of such property or any other risk.

Sufficiency of accepted Contract Amount 4.10

The Contractor shall be deemed to have satisfied himself as to the correctness and sufficiency of the Contract Price. Unless otherwise stated in the Contract, the Contract Price shall cover all his obligations under the Contract and all things necessary for the proper design,

237

GENERAL CONDITIONS OF CONTRACT

execution and completion of the Works, testing and commissioning (including Integrated Testing and Commissioning) and remedying of any defects.

Access Route 4.11

The Contractor shall be deemed to have satisfied himself as to the suitability and availability of the access routes he chooses to use. The Contractor shall (as between the Parties) be responsible for the maintenance of access routes. The Contractor shall provide at his cost signs or directions, which he may consider necessary or as instructed by Engineer for the guidance of his staff, labour and others. The Contractor shall obtain any permission concessions and related easement right that may be required from the relevant authorities for the use of such routes, signs and directions.

The Employer will not be responsible for any claims which may arise from the use or otherwise of any access route. The Employer does not guarantee the suitability or availability of any particular access route, and will not entertain any claim for any non-suitability or non-availability for continuous use during construction of any such route.

Rights of Way and Facilities 4.12

The Employer will acquire and provide land for Permanent Works and right of way (within NMRC's land) for access thereto over routes established by the Contractor. The Contractor shall bear all cost and charges for special or temporary rights of way which he may require including those for access to the Site. The Contractor shall also obtain, at his risk and cost, any additional facility outside the Site which he may require for the purpose of the Works. The Employer reserves the right to make use of these service roads/rights of way for itself or for other Contractors working in the area, as and when necessary without any payment to the Contractor.

Programmes 4.13

The Contractor shall submit a detailed Programme to the Engineer after receipt of the Letter of Acceptance not later than 28 days from the date of receipt of Letter of Acceptance. The Contractor shall also submit a revised Programme whenever the Engineer finds that the previous Programme is inconsistent with actual progress or with the Contractor's obligations.

Each Programme shall include the following:

- a. the order in which the Contractor proposes to carry out the Works (including each stage of design, procurement, manufacture, delivery to Site, construction, erection, testing and commissioning),
- b. all major events and activities in the production of Construction or Manufacture Documents; and
- c. the sequence of all tests specified in the Contract including Integrated Testing and Commissioning.

Unless otherwise stated in the Contract, the Programmes shall be developed using precedence networking techniques, showing early start, late start, early finish and late finish dates.

No significant alteration to the Programmes, or to such arrangements and methods, shall be made without obtaining consent of the Engineer. If the progress of the Works does not conform to the Programmes, the Engineer may instruct the Contractor to revise the Programmes, showing the modifications necessary to achieve completion within the Time for Completion.

Consent by the Engineer to Programmes shall not relieve the Contractor

GENERAL CONDITIONS OF CONTRACT

of any of his responsibilities or obligations under the Contract. If the Programmes indicate that a Key Date has not, or will not be met, it shall not, by itself entitle the Contractor to an extension of time in relation to such Key Date or would entitle the Contractor for any amount of money/damages/compensation.

Progress Reports 4.14

The Contractor shall submit to the Engineer by the end of each calendar month his Monthly Progress Report which shall, amongst other things, highlight actual or potential departures from the Works Programmes and/or the Design Submission Programme and state the measures which the Contractor proposes to take in order to make good or reduce any delay. The submission of Monthly Progress Report by the Contractor would not absolve the Contractor of its obligation/right to notify any events/information to the Employer. The submission of Monthly Progress Report by Contractor would not amount to admission of its content by the Employer.

If requested by the Engineer, the Contractor shall submit to the Engineer, at weekly intervals, a written report as to the progress of off-Site manufacture of Plant, Rolling Stock and Materials.

The Contractor shall also submit to the Engineer such other reports as may reasonably be required by him or any relevant authority or public body.

The progress reports shall conform to the Employer's Requirements.

Contractor's Equipment 4.15

4.15.1 All Contractor's Equipment and Temporary Works provided by the Contractor shall, when brought on to the site, be deemed to be exclusively intended for execution of the Works and not be removed without the consent in writing of the Engineer. Such consent shall not be unreasonably withheld or delayed.

4.15.2 Upon completion of the Works, the Contractor shall remove from the Site all the said Constructional Plant and his unused materials

4.15.3 The Employer shall not, at any time, be liable for the loss or damage to any of the Constructional Plant, Temporary Works or materials save as mentioned in Clauses 14.1.

4.15.4 In respect of any Constructional Plant which the Contractor shall have imported for the purpose of the Works, the Employer may assist the Contractor, where required, in procuring any necessary Government consent for re-export of the same after the completion of the Works.

4.15.5 The Employer may assist (but is not obligated to) the Contractor, where required, in obtaining clearance through the Customs of Constructional Plant, materials and other things required for the Works.

Safety of Works 4.16

The Contractor shall throughout the execution of the Works including the carrying out of any testing, commissioning (including Integrated Testing and Commissioning), or remedying of any defect:

a. take full responsibility for the adequacy, stability, safety and security of the Works, Plant, Rolling Stock, Contractor's Equipment, Temporary Works, operations on Site and methods of manufacture, installation, construction and transportation;

b. have full regard for the safety of all persons on or in the vicinity of the Site (including without limitation persons to whom access to the

235

GENERAL CONDITIONS OF CONTRACT

Site has been allowed by the Contractor), comply with all relevant safety regulations, including provision of safety gear, and in so far as the Contractor is in occupation or otherwise is using areas of the Site, keep the Site and the Works (so far as the same are not completed and occupied by the Employer) in an orderly state appropriate to the avoidance of injury to all persons and shall keep the Employer indemnified against all injuries to such persons.

c. provide and maintain all lights, guards, fences and warning signs and watchmen when and where necessary or required by the Engineer or by laws or by any relevant authority for the protection of the Works and for the safety and convenience of the public and all persons on or in the vicinity of the Site; and

d. where any work would otherwise be carried out in darkness, ensure that all parts of the Site where Work is being carried out are so lighted as to ensure the safety of all persons on or in the vicinity of the Site and of such Work.

Contractor is required to take note of all the necessary provisions in Employer's Conditions of Contract on Safety & Health and Environment and the Contractor's price shall be inclusive of all the necessary costs to meet the prescribed safety standards. In the case, the Contractor fails in the above, the Employer may provide the necessary arrangements and recover the costs from the Contractor.

Protection of the Environment 4.17

The Contractor shall take all reasonable steps to protect the environment (both on and off the Site) and to avoid injury, damage and nuisance to people and property resulting from pollution, noise and other results of his operations. The Contractor shall ensure that air emissions, surface discharges and effluent from the Site during the Contract Period shall not exceed the values indicated in the Employer's Requirements, and shall not exceed the values prescribed by law. The Contractor shall conform to the Employer's Requirements and shall indemnify the Employer against any liability or damages or claims arising out of his operations. The Contractor shall be responsible and liable for any stoppage, closure or suspension of the works due to any contravention of statutory requirements relating to the protection of the environment and shall indemnify and keep indemnified the Employer in this regard.

The Contractor's Site Environmental Plan shall be developed from his Employer's Conditions of Contract on Safety & Health and Environment, as per the Employer's Requirements and Special Conditions of Contract. Nothing extra shall be payable to the Contractor on this account and his Tender price shall be inclusive of expenditure required to be incurred for working as per Conditions of Contract on Safety & Health and Environment.

Electricity Water and Gas 4.18

The Contractor shall be responsible for making his own arrangements at his own cost to obtain supply of water, electricity or gas for the Works. The Employer where feasible may at its discretion assist the Contractor in this respect.

Tools, Plants and Equipment Supplied by the Employer 4.19

Except for any specific item mentioned in the Special Conditions of Contract or in Employer's Requirements, the Contractor shall provide all Tools, Plants and Equipment for the Works. In respect of such exceptional Tools, Plants or Equipment committed to be provided by the Employer under terms and conditions specified in the Special Conditions of Contract, the Contractor shall take all reasonable care and shall be

GENERAL CONDITIONS OF CONTRACT

responsible for all damages or loss caused by him, his representatives, sub- contractors or his workmen or others while they are in his charge.

On completion of the Works, the Contractor shall hand over the unused balance of the Tools, Plants and Equipments to the Employer in good order and repair, fair wear and tear expected, and shall be responsible for any failure to account for the same or any damage done thereto.

The decision of the Engineer as to the amount recoverable from the Contractor on this account shall be final and binding.

Employer's Materials & Excavated Materials

4.20

(i) Except for items mentioned in the Special Conditions of Contract, the Contractor shall provide all materials for the Works. Material if any, to be provided by Employer will be done only in a phased manner as per pre-approved program, against a Bank Guarantee for the value of the Material and at terms and conditions for issue, upkeep, usage, return and recovery of such Materials as specified in Special Conditions of Contract.

(ii) Unless otherwise specified, the Contractor shall not sell or remove, except for the purpose of this Contract, sand, stone, clay, ballast, earth, rock or other materials obtained from the Work Site and these shall be the property of the Employer and will be disposed off only in the manner instructed by him.

Sheds, Stores, Yards

4.21

It shall be the responsibility of the Contractor to provide at his own expense the required sheds, store houses, and yards for both Permanent and Temporary Works and provide free access to the Engineer and the Engineer's Representative who will have right of inspection including that of instructing the Contractor to remove a particular material from the stores and not to use the same on the Works.

Temporary Works

4.22

All temporary Works necessary for the proper execution of the Works shall be provided and maintained by the Contractor at his own cost and subject to the consent of the Engineer shall be removed by Contractor at his own expense when they are no longer required and in such manner as the Engineer shall direct. In case the Contractor fails to remove the temporary Works on completion, the Engineer is authorized to get the same removed and recover the cost thereof from the Contractor.

Unforeseeable Physical Conditions

4.23

In this Clause "physical conditions" means natural physical conditions, which the Contractor encounters at Site while executing the Works excluding climatic conditions.

If, during the execution of the Works, the Contractor shall encounter physical conditions, which, in his opinion, could not have been reasonably foreseen by an experienced Contractor, the Contractor shall forthwith give written notice thereof to the Engineer and if, in the opinion of the Engineer, such conditions could not have been reasonably foreseen by an experienced Contractor, then the Engineer may certify and the Employer shall may pay reasonable additional cost to which the Contractor shall have been put by reason of such conditions in the following cases:

- a. for complying with any instruction which the Engineer may issue to the Contractor in connection therewith, and
- b. for any proper and reasonable measures approved by the Engineer which the Contractor may take in the absence of specific instructions from the Engineer, as a result of such conditions or

233

GENERAL CONDITIONS OF CONTRACT

obstructions being encountered.

The decision of the Engineer as to the additional cost shall be final and binding.

Access for Engineer 4.24

The Contractor shall allow the Engineer or the Engineer's Representative or any other person authorised by him, at all times access to the Site, and to any place where Work in connection with the Contract is being carried out or is intended to be carried out and to any place where materials or plant are being manufactured, fabricated and/or assembled for the Works. The Contractor shall ensure that sub-contracts if any shall contain provisions entitling the Engineer or any person authorised by him to have such access.

Access Road and Way Leaves 4.25

Providing access roads/ way leaves to the site will be Contractor's responsibility.

Contractor to keep Site Clear 4.26

During the execution of the Works, the Contractor shall keep the Site free from all unnecessary obstruction, and shall store or dispose of any Contractor's Equipment or surplus materials. The Contractor shall clear away and remove from the Site, any wreckage, rubbish or Temporary Works which are no longer required.

On completion of the Works, the Contractor shall clear away and remove from site all Contractor's Plant, surplus material and Temporary Works. He should leave the whole of the site and Works in a clean, tidy and workman like condition to the satisfaction of the Engineer.

On completion of Work, the Contractor shall also clear away the labour camps, hutments and other related installations and restore the land to its original condition to the satisfaction of the Engineer within 45 days of the physical completion of Work. The cost on account of delay in return of land and reinstatement to its original condition within the stipulated time as determined by Engineer, will be recovered from the Contractor's dues.

No final payment in settlement of the accounts for Works shall be made or held to be due to the Contractor, till, in addition to any other condition necessary for such final payment, site clearance and clearances of labour camps etc. shall have been effected by him. Such clearance may be made by the Engineer through any other agency at the expense of the Contractor, in the event of the Contractor's failure to comply with this provision within 7 days after receiving notice to that effect from the Engineer. All expenses on such removal/clearance shall be debitable to the Contractor as loans due from the Contractor to the Employer, and the Employer shall be competent to recover the same from Contractor's on-account or final bills, or from Performance Security amount or from any other amount payable to the Contractor in any other Contract.

Security of the Site 4.27

The Contractor shall be wholly responsible for security of Site and Works.

Unless otherwise stated in Special Conditions of Contract

a. the Contractor shall be responsible for keeping unauthorized persons off the Site; and

b. Authorized persons shall be limited to the Employees of the Contractor, Sub-contractor or persons authorized by the Engineer.

Contractor's Operations on 4.28

The Contractor shall confine his operations to the Site, and to any additional area which may be provided to the Contractor and agreed by

GENERAL CONDITIONS OF CONTRACT

Site		the Engineer as working areas. The Contractor shall take all necessary precautions to keep his personnel and equipment within the Site and such additional areas, and to keep and prohibit them from encroaching on adjacent land.
Discoveries	4.29	All fossils, coins, articles of value or antiquity, structures and other remains or things of geological or archaeological interest, in addition to oil and other minerals discovered on the Site shall be the absolute property of the Government of India. The Contractor shall take all the necessary precautions to prevent its workmen or its Sub-contractors' workmen or any other person from removing or damaging any such article or thing and shall immediately upon discovery thereof, acquaint the Engineer of such discovery and carry out the instructions of the Engineer.
Publicity	4.30	The Contractor shall not publish or otherwise circulate alone or in conjunction with any other person, any articles, photographs or other materials relating to the Contract, the Site, the Works, the Project or any part thereof, nor impart to the Press, or any radio or television network any information relating thereto, nor allow any representative of the media access to the Site, Contractor's Works Areas, or off-Site place of manufacture, or storage except with the permission, in writing, of the Employer. The Contractor shall ensure that his Sub-contractors of any tier shall be bound by similar obligation and shall, if so required by the Employer, enforce the same at his own expense. The provisions of this Sub-clause shall not exempt the Contractor from complying with any statutory provision in regard to the taking and publication of photographs.
Disclosure of Relationship	4.31	If the Contractor or any partner of the Contractor or Director of the Contractor's company is closely related to any of the Officers of the Employer or the Engineer, or alternatively, if any close relative of an officer of the Employer or the Engineer has financial interest/stake in the Contractor's firm, the same shall be disclosed by the Contractor at the time of filing his tender. Any failure to disclose the interest involved, shall entitle the Employer to rescind the Contract, without payment of any compensation to the Contractor. The Contractor shall note that he is prohibited from developing such interest during the Contract period also.
Use of Explosives	4.32	Explosives if required on the Work shall be used by Contractor only with prior Approval of the Engineer and in the manner and to the extent permitted by him. The Contractor shall be responsible for safe upkeep of such explosives in a special magazine as per the law on explosives as well as for taking all the precautions in the usage of the explosives with proper license and at Contractor's cost, sole risk and responsibility. The Contractor shall hold the Employer harmless and indemnify for the above.
Corrupt /or Fraudulent/ Collusive/ Coercive Practices	4.33	
Definition	4.33.1	The Employer requires that the Bidders/Contractors, their designated Contractors and/or their Agents observe the highest standards of ethics during Tendering and execution of this Contract. In pursuance with this Policy, the Employer:

231

GENERAL CONDITIONS OF CONTRACT

a. defines, for the purpose of these provisions, the terms set forth below as follows:

(i) "corrupt practice" means the offering, giving, receiving or soliciting of anything of value to any officer/employee of NMRC or Engineer or to any other person to influence in the procurement process or in Contract execution and/or after the execution of the Contract.

(ii) "fraudulent practice" means a concealment or misrepresentation of facts in order to influence a procurement process or during the execution of a Contract and/or after the execution of the Contract, which may or may not be to the detriment of the Employer and includes collusive practice among Bidders (prior to or after bid submission) designed to establish bid prices at artificial non-competitive levels and to deprive the Employer of the benefits of free and open competition and further includes concealment or misrepresentation of facts leading to breach of any of the Contract condition during execution of the Contract which may or may not be to the detriment of the Employer.

(iii) "collusive practice" means amongst Bidders (prior to or after bid submission) a scheme or arrangement designed to establish bid prices at artificial non-competitive levels and to deprive NMRC of the benefits of free and open competition.

(iv) "coercive practice" means impairing or harming or threatening to impair or harm directly or indirectly, any Agency or NMRC or its employees/ consultants or its property, to influence improperly the actions of an Agency or NMRC or its employees/ consultants, obstruction of any investigation or auditing of a Procurement/ Contract process.

(v) Breach of any of the contract condition during execution.

(vi) "Suspension": Business dealings with an Agency may be suspended in exceptional cases if there is gross and blatant violation of the provisions of the Suspension/ Banning Policy by the Agency and it is considered not desirable to continue the business with the Agency pending detailed enquiry for Banning of Business Dealing. Suspension shall be for a period upto six months from the date of approval of decision of Suspension.

(vii) "Banning": Shall mean officially debarring or forbidding an Agency from participating as Vendor/ Supplier/Contractor etc. with NMRC, for its requirement related to all Tenders / Contracts. Business dealings with an Agency may be banned if it violates/ infringes the provisions of the Suspension/ Banning policy of the NMRC. Banning shall be for a period ranging from one year from the date of issue of Banning Order or Suspension Order (If suspension imposed on the Agency) and upto five years.

(a) If it is found that the Bidder/Contractor has indulged in corrupt/fraudulent/ collusive/coercive practices, actions such as rejection of bid/forfeiture of Tender Security or rescission/termination of Contract/forfeiture of Performance Security etc. shall be taken as per Suspension/Banning Policy of NMRC.

(b) The successful Bidders/Contractors shall apprise the Employer through Chief Vigilance Officer, NMRC of any fraud/suspected fraud/corrupt practices as soon as it comes to their notice.

GENERAL CONDITIONS OF CONTRACT

Compensation to Contractor on rescission of Contract 4.33.2 In the event of rescission of Contract under Sub-clause 4.33.1, the Contractor shall not be entitled to any compensation whatsoever, except for the Work done up to the date of rescission, payable as per the provisions of the Contract.

5 DESIGN

The clauses under the head 'Design' are applicable only in 'Design & Build' Contracts and in case of 'Part Design & Build' Contracts, these are applicable only to part of the Contract in which the design is the responsibility of the Contractor.

General Obligations 5.1 The Contractor shall design and provide all necessary specifications for the Works in accordance with the site plans and Employer's requirements. Any design detail, plan, drawing, specifications, notes, annotations, and information required shall be provided in such sufficient format, details, extent, size and scale and within such time as may be required to ensure effective execution of Works and/or as otherwise required by the Engineer.

The Contractor holds himself, and his Designers as having the experience and capability necessary for the design. The Contractor undertakes that the Designers shall be available to attend discussions with the Engineer at all reasonable times during the Contract Period.

The Designer shall be the same entity as proposed by the Contractor at the time of pre-qualification, unless otherwise approved by the Employer. The Contractor shall furnish Designer's Warranty in the format approved by the Employer.

Contractor's warranty of design 5.2 a. The Contractor shall be fully responsible, for the suitability, adequacy, integrity, durability and practicality of the Contractor's proposal and design.

b. The Contractor warrants that the Contractor's Proposals and design meet the Employer's Requirements and is fit for the purpose thereof. Where there is any inadequacy, insufficiency, impracticality or unsuitability in or of the Employer's Requirements or any part thereof, the Contractor's Proposal shall take into account, address or rectify such inadequacy, insufficiency, impracticality or unsuitability at Contractor's OWN COST.

c. The Contractor warrants that the Works have been or will be designed, manufactured, installed and otherwise constructed and to the highest standards available using proven up-to-date good practice

d. The Contractor warrants that the Works will, when completed, comply with enactments and regulations relevant to the Works

e. The Contractor warrants that the design of the Works and the manufacture of Plant have taken or will have taken full account of the effects of the intended manufacturing and installation methods, Temporary Works and Contractor's Equipment

f. The Contractor shall also provide a Guarantee from the Designer for the design for suitability, adequacy, practicality of design for Employer's Requirements

g. The Contractor shall indemnify the Employer against any damage, expense, liability, loss or claim, which the Employer might

229

GENERAL CONDITIONS OF CONTRACT

incur, sustain or be subject to arising from any breach of the Contractor's design responsibility and/or warranty set out in this Clause.

h. The Contractor further specifies and is deemed to have checked and accepted full responsibility for the Contractor's Proposal and warrants absolutely that the same meets the Employer's Requirements:

(i) Notwithstanding that such design may be or have been prepared, developed or issued by the Employer, any of Contractor's Consultants, his Sub-contractors and/or his qualified personnel/persons or cause to be prepared, developed or issued by others.

(ii) Notwithstanding any warranties, guaranties and/or indemnities that may be or may have been submitted by any other person.

(iii) Notwithstanding that the same have been accepted by the Engineer

The Contractor shall be fully responsible for the Plants, Materials, goods, workmanship, preparing, developing and coordinating all design Works to enable that part of the Works to be constructed and/or to be fully operational in accordance with the Contract's requirements.

Apart from the Contractor, the above warranty shall also be applicable for his Designer. This warranty shall be a part of his Sub-contract with the Designer and should be made available at the time of signing of the Agreement.

No claim for additional payment or extension of time shall be entertained and/or the Contractor shall not be relieved from any obligation/liability under the Contract, for any delay, suspension, impediment to or adverse effect upon the progress of the Works due to any mistake, inaccuracy, discrepancy or omission in or between the Contractor's, the Definitive Design and the final design, or any failure by the Contractor to prepare any Design Data or submit the same to the Engineer in due time and the Contractor shall promptly make good any such defect at his own cost.

Construction and/or Manufacture Documents

5.3

The Manufacture Documents shall comprise the technical documents specified in the Employer's Requirements, documents required to satisfy all regulatory approvals, documents described in Sub Clause 5.6 (As Built Document), and Sub Clause 5.7 (Operations and Maintenance Manuals). The Contractor shall prepare all Manufacture Documents in sufficient detail and shall also prepare any other document necessary to instruct the Contractor's personnel. The Engineer shall have the right to inspect the preparation of all these documents wherever they are being prepared.

Each of the Construction and/or Manufacture Documents shall, when considered ready for use, be submitted to the Engineer for pre-construction or pre-manufacture review. Unless otherwise stated in Employer's Requirements, each review by the Engineer shall not exceed 21 Days, calculated from the date on which the Engineer receives the Manufacture Document.

The Engineer may during the review period, give notice to the Contractor that a Manufacture Document fails (to the extent stated) to comply with the Employer's Requirements, it shall be rectified, resubmitted and reviewed (and if specified, approved) in accordance with this Sub-clause, at the Contractor's cost.

For each part of the Works, and except to the extent that the prior

GENERAL CONDITIONS OF CONTRACT

consent of the Engineer shall have been obtained:

a. In the case of a Construction and/or Manufacture Document which has (as specified) been submitted for the Engineer's approval

(i) The Engineer shall give notice to the Contractor that the Construction and/or Manufacture Document is provided with no objection, with or without comments, or that it fails (to the extent stated) to comply with the Contract

(ii) Execution of such part of the Works shall not commence until the Engineer has provided with no objection for the Construction and/or Manufacture Document; and

(iii) The Engineer shall be deemed to have provided with no objection for the Construction and/or Manufacture Document upon the expiry of the review periods for all the Construction and/or Manufacture Documents which are relevant to the design and execution of such parts, unless the Engineer has previously notified otherwise in accordance with sub-paragraph (i)

b. construction and/or manufacture of such part of the Works shall not commence prior to the expiry of the review of the Construction and/or Manufacture Documents which are relevant to its design and execution;

c. construction and/or manufacture shall be in accordance with such reviewed (and if specified, approved) Construction and/or Manufacture Documents; and (d) if the Contractor wishes to modify any design or document which has previously been submitted for such pre-construction and/or pre-manufacture review, the Contractor shall immediately notify the Engineer, and based on Engineer's approval shall subsequently submit revised documents to the Engineer in accordance with the above procedure.

If the Engineer instructs that further Construction and/or Manufacture Documents are necessary for carrying out the Works, the Contractor shall promptly and at Contractor's cost prepare such documents,

Errors, omissions, ambiguities, inconsistencies, inadequacies and other defects if found at any stage in construction or any operations manufacture documents, then shall be rectified by the Contractor at his own cost and any approval or consent or review (under this sub-clause or otherwise) by the Employer/Engineer of the Manufacture and Construction Documents under this Sub-clause shall not relieve the Contractor from any obligations or responsibility under the Contract.

Technical Standards and Regulations 5.4

The design, the Construction and/or Manufacture Documents, the execution and the completed Works (including remedying of defects therein) shall comply with the specifications, technical standards, building construction, safety and environmental regulations and other standards specified in the Employer's Requirements applicable to the Works or defined by the applicable laws and regulations

Samples 5.5

The Contractor shall submit at his own cost the following samples and relevant information to the Engineer for pre-construction and/or pre-manufacture review in accordance with the procedure for Construction and/or Manufacture Documents described in Sub-clause 5.3:

227

GENERAL CONDITIONS OF CONTRACT

- a. manufacturer's standard samples of Materials,
- b. samples (if any) specified in the Employer's Requirements. Each sample shall be labelled as to origin and intended use in the Works

As-Built Drawings and Documents 5.6

This clause is applicable for 'Build' part of Contract also. The Contractor shall prepare, and keep up-to-date, a complete set of "as-built" records of the execution of the Works, showing the exact "as-built" locations, sizes and details of the Works as executed, with cross references to relevant specifications and data sheets. These records shall be kept on the Site and shall be used exclusively for the purposes of this Sub-clause. Six copies shall be submitted to the Engineer prior to the commencement of the Tests on Completion.

In addition, the Contractor shall prepare and submit to the Engineer "as-built drawings" of the Works, showing all Works as executed. The drawings shall be prepared as the Works proceed, and shall be submitted to the Engineer for his inspection. The Contractor shall obtain the consent of the Engineer as to their size, the referencing system, and other pertinent details.

Prior to the issue of any Taking Over Certificate, the Contractor shall submit to the Engineer one soft copy and four printed copies of the relevant "as-built drawings", and any further Construction and/or Manufacture Documents specified in the Employer's Requirements. The Works shall not be considered to be completed for the purposes of Taking Over under Sub-clause 9.1 until such documents have been submitted to the Engineer.

Operation and Maintenance Manuals 5.7

Prior to commencement of the Tests on Completion, the Contractor shall prepare, and submit to the Engineer, Operation and Maintenance Manuals in accordance with the Employer's Requirements and in sufficient detail for the Employer to operate, maintain, dismantle, reassemble, adjust and repair the Works. The Works shall not be considered to be completed for the purposes of Taking Over under Sub-clause 9.1 until such Operation and Maintenance Manuals have been submitted to the Engineer and received his consent.

Intellectual Property Rights and Royalties 5.8

The Contractor shall indemnify the Employer and the Engineer from and against all claims and proceedings on account of infringement (or alleged infringement) of any patent rights, registered designs, copyright, design, trademark, trade name, know-how or other Intellectual Property Rights in respect of the Works, Contractor's Equipment, machines, work method, or Plant, or Materials, or anything whatsoever required for the Works and from and against all claims, demands, proceedings, damages, costs, charges and expenses whatsoever in respect thereof or in relation thereto. The Contractor shall pay all traffic surcharges and other royalties, licenses fees, rent and other payments or compensation, if any, for getting stone, sand, gravel, clay or other materials, machine, process, systems, work methods, or Contractor's Equipment required for the Works. The Contractor shall, in the event of infringement of Intellectual Property Rights, rectify, modify or replace at his own cost the Works, Plant or materials or anything whatsoever required for the Works so that infringement no more exist or in the alternative shall procure necessary rights/license so that there is no infringement of Intellectual Property Rights.

The Contractor shall be promptly notified of any claim under this Sub-Clause made against the Employer. The Contractor shall, at his cost, conduct negotiations for the settlement of such claim, and any litigation

GENERAL CONDITIONS OF CONTRACT

or arbitration that may arise from it. The Employer or the Engineer shall not make any admission which might be prejudicial to the Contractor, unless the Contractor has failed to take over the conduct of the negotiations, litigation or arbitration within a reasonable time after having been so requested. In the event of Contractor failing to act at Engineer's notice, the Employer shall be at full liberty to deduct any such amount of pending claim from any amount due to the Contractor under this Contract or any other Contract.

Insofar as the patent, copyright or other intellectual property rights in any Plant, Design Data, plans, calculations, drawings, documents, Materials, know-how and information relating to the Works shall be vested in the Contractor, the Contractor shall grant to the Employer, his successors and assignees a royalty-free, non- exclusive and irrevocable licenses (carrying the right to grant sub-licenses) to use and reproduce any of the works, designs or inventions incorporated and referred to in such Plant, documents or Materials and any such know-how and information for all purposes relating to the Works (including without limitation the design, manufacture, installation, reconstruction, Testing, commissioning, completion, reinstatement, extension, repair and operation of the Works).

If any patent, registered design or software is developed by the Contractor specifically for the Works, the title thereto shall vest in the Employer and the Contractor shall grant to the Employer a non-exclusive irrevocable and royalty- free licenses (carrying the right to grant sub-license) to use, repair, copy, modify, enhance, adapt and translate in any form such Software for his own use.

If the Contractor uses proprietary software for the purpose of storing or utilizing records, the Contractor shall obtain at his own expense the grant of a licenses or sub-licenses to use such software in favors of the Employer and shall pay such licenses fee or other payment as the grantor of such licenses may require provided that the use of such software under the licenses may be restricted to use relating to the design, construction, reconstruction, manufacture, completion, reinstatement, extension, repair and operation of the Works or any part thereof.

The Contractor's permission referred to above shall be given, inter alia, to enable the Employer to disclose (under conditions of confidentiality satisfactory to the Contractor) programmes and documentation for a third Party to undertake the performance of services for the Employer in respect of such programmes and documentation.

If any software is developed under the Contract or used by the Contractor for the purposes of storing or utilizing records over which the Contractor or a third Party holds title or other rights, the Contractor shall permit or obtain for the Employer (as the case may require) the right to use and apply that Software free of additional charge (together with any modifications, improvements and developments thereof) for the purpose of the design, manufacture, installation, reconstruction, testing, commissioning, completion, reinstatement, extension, repair, modification or operation of the Works, or any part thereof, or for the purpose of any Dispute.

The Employer reserves the right to use other Software on or in connection with the Works.

225

GENERAL CONDITIONS OF CONTRACT

6 STAFF AND LABOUR

Engagement of Staff and Labour

6.1 The Contractor shall make his own arrangements for the engagement of staff and labour at his own cost.

Rates of Wages and Conditions of Labour

6.2 Full compliance of statutory requirements apart, the Contractor shall pay rates of wages and observe conditions of labour not less favourable than those fixed by appropriate Government for the industry.

The Contractor shall make himself aware of all labour regulations and their impact on the cost and build up the same in the Contract Price. During the Contract Period, no extra amount in this regard shall be payable to the Contractor, for whatsoever reason including any revision of rates payable to the labour due to revision of rates payable in Minimum Wages Act.

Labour provided by the Contractor, either directly or through Sub-contractors, for the exclusive use of the Employer or the Engineer, shall, for the purpose of this Sub-clause, be deemed to be employed by the Contractor.

In the event of default being made in the payment of any money in respect of wages of any person employed by the Contractor or any of its Sub-contractors of any tier in and for carrying out of this Contract and if a claim therefore is filed in the office of the Labour Authorities/Court and proof thereof is furnished to the satisfaction of the Labour Authority/Court, the Employer may, failing payment of the said money by the Contractor, make payment of such claim on behalf of the Contractor to the said Labour Authorities/Court and any sums so paid shall be recoverable by the Employer from the Contractor.

Persons in the service/ retired of Employer/ Engineer

6.3 a. The Contractor shall not recruit or attempt to recruit, staff and labour from amongst the Employer and the Engineer's personnel.

b. The Contractor either at the tendering stage or during construction stage will not employ any retired employee of Employer or Engineer of the Employer in any capacity unless such employee has completed at least two years post retirement period or has obtained the no-objection certificate from Employer for being employed with the Contractor. It will be responsibility of the Contractor to collect the Employer's no objection certification from such retired employee and submit the same back to the Employer.

In case of non-compliance of above, in addition to any or several of the courses, referred in Sub-clauses 13.2 being adopted by the Employer, the Contractor on Termination of the Contract for the aforesaid reasons will have no claim whatsoever against the Employer except for actual value of the Work executed till the time of Termination.

Labour Laws

6.4 a. In dealing with labour and employees, the Contractor and his Sub-contractors (including piece rate and petty Contractors) shall comply fully with all laws and statutory regulations pertaining to engagement, payment and upkeep of the labour in India.

b. The Contractor shall have a Labour Welfare Organisation which shall be responsible for labour welfare and compliance with prevalent labour laws, statutes and guidelines. The Labour Welfare Organization

GENERAL CONDITIONS OF CONTRACT

of Contractor shall comprise of such competent officials having requisite qualification as prescribed in Conditions of Contract on Safety & Health and Environment. In no case, an under qualified person may be appointed in Labour Welfare Organisation of Contractor. In this context the Contractor is also required to familiarize himself with NMRC's Labour Welfare Fund Rules as specified in Special Conditions of Contract or elsewhere in the Contract and comply with the same.

c. The Labour Welfare Organisation of Contractor shall prepare and submit a monthly compliance/Status Report of adherence to labour laws to the Engineer.

d. The Contractor will ensure to open bank accounts for each worker employed by him and his Sub-contractors and all the payments to workers will be released through bank accounts.

e. The violation of Labour Laws viz. Contractor Labour (Regulation & Abolition) Act, 1970 & Central Rules, 1971 made thereunder or other applicable Labour Laws under the jurisdiction shall attract following penalties in addition to the penalties imposed by Statutory Authorities in terms of applicable Act/Rules:-

- (i) Delay in payment of dues to any workmen: ₹100/-per day workman
- (ii) Non-compliance(s) of any other provision of labour laws, pointed out by Employer/Engineer or their representative: ₹5000/- for each non-compliance informed in writing, under the contract

The decision of Engineer with regard to the merits of imposition of penalty, determination of non-compliance and amount of penalty shall be final and binding on Contractor. The 'Contract' under this Sub-clause shall include any workmen employed by Contractor working within premises of Works at Employer's establishment whether directly or through Sub-contractor etc.

f. The Contractor shall ensure the registration of all his eligible workers inclusive of Sub-contractor and Petty Contractors with BOCW (Building and Other Construction Workers) Board.

Working Hours 6.5

The Contractor, if required, shall carry out work during night hours or in shifts, unless specifically provided otherwise in the Contract. No increase in rates or extra payments shall be admissible for night work.

The Contractor shall provide adequate lighting and safety arrangements. The Contractor shall also provide rest room if the work is being carried out in night shift.

Facilities for Staff and Labour 6.6

The Contractor shall provide and maintain at his own expense, all necessary accommodation and welfare facilities as per prevailing labour & welfare laws for his (and his Sub-contractor's) staff and labour. This includes good practices like provision of temporary crèche (BalMandir) where 50 or more women are employed at a time. All accommodation shall be maintained in a clean and sanitary condition, by the Contractor at his own cost. Separate rest room, toilets needs to be provided for female workers.

Health and Safety 6.7

Precaution shall be taken by the Contractor to ensure the health and safety of his staff and labour. The Contractor shall, in collaboration with

223

GENERAL CONDITIONS OF CONTRACT

and to the requirements of the local health authorities, ensure that medical staff, first aid facilities, sick bay and ambulance service are available at the accommodation and on the Site at all times, and that suitable arrangements are made for all necessary welfare and hygiene requirements and for the prevention of epidemics. The Contractor shall maintain records and make reports concerning health, safety and welfare of persons, and damage to property, as per the Engineer's requirement and will ensure complete compliance with relevant clauses of Employer's Health, Safety and Environment Manual (SHE Manual) Conditions of Contract on Safety & Health and Environment.

The Contractor's Site Safety Plan shall be developed from his Outline Safety Plan as per Employer's Requirements and Conditions of Contract on Safety & Health and Environment of the Employer.

The Contractor shall appoint a member of his staff at the Site to be responsible for maintaining the safety, and protection against accidents, of personnel on the Site. This person shall be qualified for the work and shall have the authority to issue instructions and take protective measures to prevent accidents.

**Contractor's
Superintendence** 6.8

The Contractor shall provide all necessary superintendence during the design and execution of the Works, and as long thereafter as the Engineer may consider necessary for the proper fulfilling of the Contractor's obligations under the Contract. Such superintendence shall be provided by sufficient persons having adequate knowledge of the operations to be carried out (including the methods and techniques required, the hazards likely to be encountered and methods of preventing accidents) for the satisfactory and safe execution of the Works.

**Provision of
Efficient and
Competent Staff** 6.9

The Contractor shall employ (or cause to be employed) only persons who are careful and appropriately qualified, skilled and experienced in their respective trades or occupations. The Engineer may require the Contractor to remove (or cause to be removed) any person employed on the Site or Works, including the Contractor's Representative, who in the opinion of the Engineer:

- a. persists in any misconduct,
- b. is incompetent or negligent in the performance of his duties,
- c. fails to conform with any provisions of the Contract, or persists in any conduct which is prejudicial to safety, health of workers, or the protection of the environment.

**Preservation of
Peace and
orderly conduct** 6.10

6.10.1 The Contractor shall be responsible for preservation of peace and orderly conduct at the site and its neighborhood by Contractor's employees, Representatives, petty Contractors, Sub-contractors etc. In case, deployment of a Special Police Force becomes necessary at or near Site, during the tenure of Works, the expenses for the same shall be borne by the Contractor.

6.10.2 The Contractor shall at all times take all reasonable precautions which will include that no labour or employee is permitted to work at site in an intoxicated state or under influence of drugs, to prevent any unlawful, riotous or disorderly conduct by or amongst his staff and labour, and to preserve peace and protection of persons and property in the

GENERAL CONDITIONS OF CONTRACT

neighborhood of the Works against such conduct.

Labour to be Contractor's Employee 6.11 If, the Contractor directly or through petty Contractors or Sub-contractors supplies any labour to be used wholly or partly under the direct orders and control of the Engineer or the Employer, whether in connection with any Work being executed by the Contractor or otherwise for the purposes of the Employer, such labour shall, for the purpose of this clause, be deemed to be persons employed by the Contractor.

Report of Accidents to Labour 6.12 The Contractor shall be responsible for safety of all employees, employed by him on Works, directly or through petty Contractors or Sub-contractors, and shall report accidents relating to any of them, however, and wherever occurring on Works, to the Engineer or the Engineer's Representative and shall make every arrangement to render all possible assistance and to provide prompt and proper medical attention. The compensation for affected workers or their relatives shall be paid by the Contractor in such cases with utmost expeditiously in accordance with the Workmen's Compensation Act or ESI Act as applicable.

Claim on account of violation of Labour laws 6.13 The Contractor shall be solely accountable for violation of any labour law by it, its petty Contractors or Sub-contractors and will pay any such claim/damage to the authorities forthwith on demand. If any money shall, as a result of any instructions, directions or decisions from the Authorities/Court or claim or application made under any of the labour laws or regulations, be directed to be paid by the Employer, such money shall be deemed to be money payable to the Employer by the Contractor and he will pay the same to the Employer forthwith on demand, without demur and without asking for any reasons/explanations from the Employer. On failure of the Contractor to repay the Employer any money paid or to be paid by it as aforesaid within seven days after the same shall been demanded, the Employer shall be entitled to recover the amount from any money due or accruing to the Contractor under this or any other Contract with the Employer.

Maintenance of Records 6.14 The Contractor shall maintain all records pertaining to labour as mandated by the law of the land and shall keep it preserved at least for three years after the completion of the Project.

7 **QUALITY CONTROL**

Manner of Execution 7.1 All Plant, goods, and Materials to be supplied shall be manufactured, and all Work to be done shall be executed, in the manner set out in the Contract. Where the manner of manufacture and execution is not set out in the Contract, the work shall be executed in a proper, workman like and careful manner, with properly equipped facilities and non-hazardous Materials, and in accordance with modern recognized good practice.

Source of Materials 7.2 Sources of Materials being supplied shall be intimated to the Engineer and are subject to his approval. Materials that are not specified in the Contract document shall conform to the relevant Indian Standards or in their absence, shall conform to any International Standard approved by the Engineer.

Save as otherwise expressly provided in the Contract, samples shall be supplied by the Contractor at his own cost.

Delivery to Site 7.3 The Contractor shall be responsible for procurement, transport, receiving, unloading and safe keeping of all Plant, Rolling Stock, and Construction, Materials, Contractor's Equipment and other things

22

GENERAL CONDITIONS OF CONTRACT

required for the completion of the Works.

Inspection 7.4

The Employer and the Engineer shall at all reasonable times

a. have full access to all parts of the Site and to all places from which natural materials are being obtained, and

b. during production, manufacture, fabrication and construction (at the site and elsewhere) be entitled to inspect, examine, measure and test the materials and workmanship, and to check the progress of manufacture, of all Plant, goods, construction and Materials to be supplied under the Contract.

The Contractor shall give the Engineer full opportunity to carry out these activities including providing access, facilities, permissions and safety equipments. No such activity/inspection shall relieve the Contractor from any obligation or responsibility.

Testing 7.5

This sub clause shall apply to all tests specified in the Contract, other than the Tests after Completion.

The Contractor shall provide all documents and other information necessary for all types of testing and such assistance, labour, materials, electricity, fuel, stores, apparatus and instruments as are necessary to carry out such tests efficiently.

The Contractor shall agree, with the Engineer, the time and place for the testing of any Plant, goods, Materials and other parts of the Works as specified in the Contract. The Employer/Engineer may instruct the Contractor for any additional test, at Employer's cost.

The Engineer shall give the Contractor not less than 24 hours' notice of his intention to attend the tests.

If the Engineer does not attend at the time and place agreed, or if the Contractor and the Engineer agree that the Engineer shall not attend, the Contractor may proceed with the tests, unless the Engineer instructs the Contractor otherwise. Such tests shall be deemed to have been made in the Engineer's presence.

The Contractor shall promptly forward to the Engineer duly certified reports of the tests. If the Engineer has not attended the tests, he shall accept the readings as accurate. When the specified tests have been passed, the Engineer shall endorse the Contractor's test certificate, or issue a certificate to him, to that effect.

The expense of conducting such Tests shall be borne by the Contractor. No such testing shall relieve the Contractor from any obligation or responsibility.

Rejection 7.6

i. If, as a result of inspection, examination or testing, any Plant, goods, Material, design or workmanship is found to be defective or otherwise not in accordance with the Contract, the Engineer may reject the same duly giving notice to the Contractor with reasons. The Contractor shall then promptly make good the defect and ensure that the rejected item after rectification complies with the Contract.

ii. If the Engineer requires such Plant, Goods, Material, Design or Workmanship to be retested, the tests shall be repeated under the same terms and conditions. If such rejection and retesting cause the Employer to incur additional costs, such costs shall be recoverable from the Contractor by the Employer, and may be deducted by the Employer

GENERAL CONDITIONS OF CONTRACT

from any sum due, or to become due, to the Contractor.

i. Notwithstanding any previous Test or certification, the Engineer shall have the authority to instruct the Contractor:-

a. To remove from the Site and replace any plant or Materials which is not in accordance with the Contract.

b. To remove and re-execute any other work which is not in accordance with the Contract.

i. Execute any work which is urgently required for the safety of the Works, whether because of an accident, unforeseeable event or otherwise.

i. In case of default on the part of the Contractor in carrying out such order, the Employer shall be entitled to employ and pay other Parties, to carry out the same, and all expenses consequent thereof or incidental thereto, shall be recoverable from the Contractor or may be deducted by the Employer from any sum which may be due to the Contractor.

Liability after Inspection and Testing

7.7

The Contractor shall not be released from any liability or obligation under the Contract by reason of any such inspection or testing or witnessing of testing, or by the submission of reports of inspection or testing to the Engineer.

Ownership of Plant and Materials

7.8

Each item of Plant, goods, and Material shall become the property of the Employer, when it is delivered to Site or payment thereof, either in part or full, has been made. The Contractor shall however continue to bear the risk in respect of such items which continue to remain in his custody.

Cost of Employer's Attendance Including Travel

7.9

The Employer shall bear the costs of attendance including travel by the Employer or his Representative for the purposes of Sub-clauses 7.4 and 7.5 above. The cost of attendance including travel by the Employer, Engineer or his Representative for the purpose of Sub-clause 7.6 shall be borne by the Contractor.

Covering up of Works

7.10

Examination of Work before covering up

7.10.1

No Work or part of Work shall be covered up or put out of view, without the prior approval of the Engineer or the Engineer's Representative.

Cost of uncovering the Work already covered up

7.10.2

The Contractor shall uncover any part or parts of the Works, or make openings in or through the same, as the Engineer may from time to time direct, and shall reinstate and make good such part or parts, to the satisfaction of the Engineer. If any such part or parts have been covered up, or put out of view after compliance with the requirement of Sub-clause 7.11.4 and the Works are found to be executed in accordance with the Contract, the expenses of uncovering, making openings in or through, reinstating and making good the same, shall be borne by the Employer, but if the Works are found to be defective, costs shall be borne by the Contractor.

In case after completion of a part of the Work, the part of Work is not fully consistent with the Employer's Requirements and there is no way to change the same, in that case, the same (provided it has no implication on safety and operation) shall be accepted only at a Contractor's deemed variation at lower negotiated price.

219

GENERAL CONDITIONS OF CONTRACT

The decision of the Engineer in this regard shall be final and binding on the Contractor.

Tests after Completion 7.11

Contractor's Obligations 7.11.1

The Contractor shall carry out the Tests on Completion at his own cost in accordance with the Contract after providing the documents in accordance with Sub-clauses 5.4 and 5.5. The Contractor shall give, to the Engineer, 21 days' notice of the date after which the Contractor will be ready to carry out the Tests on Completion. Unless otherwise agreed, such Tests shall be carried out within 14 days after this date, on such day or days as the Engineer shall instruct.

Unless otherwise stated in Special Conditions of Contract, the Tests on Completion shall be carried out in the following sequence

- a. pre-commissioning test, which shall include appropriate instructions and ("dry" or "cold") functional tests to demonstrate that each item of the Plant, goods and Work can safely undertake the next stage
- b. Commissioning Test shall include the specified operational tests to demonstrate that Works or Sections can be operated safely and as specified under all available operating condition
- c. trial operation which shall demonstrate that the Works or Section perform reliably and in accordance with the Contract

The Contractor at his cost shall arrange all tools, equipments, gadgets, facilities or as deemed necessary by the Engineer for such tests, In considering the results of the Tests on Completion, the Engineer shall make allowances for the effect of any use of the Works by the Employer on the performance or other characteristics of the Works. As soon as the Works, or a Section, have passed the Tests on Completion described in sub-paragraphs (a), (b) or (c), the Contractor shall provide the Engineer and the Employer with a certified report of the results of all such Tests

Delayed Tests 7.11.2

If the Engineer opines that Tests on Completion are being unduly delayed by the Contractor, the Engineer may by notice require the Contractor to carry out such Tests within 21 days after the receipt of the notice. The Contractor shall carry out such Tests on such day or days as the Contractor may fix and of which he shall give notice to the Engineer.

If the Contractor fails to carry out the Tests on Completion within 21 days, the Engineer may proceed with such Tests at the risk and cost of the Contractor. The Tests on Completion then shall be deemed to have been carried out in the presence of the Contractor and the results of such Tests shall be accepted as accurate.

Retesting 7.11.3

If the Works, or a part thereof, or a Section, fail to pass the Tests on Completion, Sub-clause 7.6 "Rejection" shall apply, and the Engineer or the Employer may require such failed Tests, and the Tests on Completion on any related work, to be repeated under the same terms and conditions.

Failure to Pass Tests on Completion 7.11.4

If the Works, or a part thereof, or a Section, fail to pass the Tests on Completion, repeated under Sub-clause 7.11.3, the Engineer shall be entitled to:

- a. order further repetition of Tests on Completion under Sub-clause

GENERAL CONDITIONS OF CONTRACT

7.11.3; or

b. reject the Works, or a part thereof, or a Section (as the case may be), in which event the Employer shall have the same remedies against the Contractor as are provided under Clause 13; or

c. issue a Taking Over Certificate, if the Employer so requires. The Contract Price shall then be reduced by such amount as determined by the Engineer and as shall be appropriate to cover the reduced value to the Employer as a result of this failure. The Contractor shall then proceed in accordance with his other obligations under the Contract.

Integrated testing and system commissioning 7.12

Integrated Testing 7.12.1 Tests on Completion shall also include Integrated Testing where applicable as per the Contract conditions. The Contractor shall, following satisfactory completion of tests on his Works, equipment, sub-systems or system, perform, at the direction of the Engineer, programme of tests to verify and confirm the compatibility and complete performance of his Works, equipment, sub-systems or system with the Works, equipment, sub-systems or system provided by others.

Compilation of Test Results 7.12.2 The results of the Integrated Testing and Commissioning shall be compiled and evaluated by the Engineer and the Contractor.

Retesting 7.12.3 If the Works, or a part thereof, or a Section, fail to pass the Integrated Testing and Commissioning, the Engineer shall require such failed Tests, to be repeated under the same terms and conditions. If such failure and retesting result from a default of the Contractor and cause the Employer to incur additional costs, the same shall be recoverable from the Contractor by the Employer, and may be deducted by the Employer from any money due, or to become due, to the Contractor.

Failure to Pass Test 7.12.4 If the Works, or a part thereof, or a Section, fail to pass Integrated Testing and Commissioning and the Contractor in consequence proposes to make any adjustment or modification to the Works or a part thereof, or a section, the Engineer may, with the approval of the Employer, instruct the Contractor to carry out such adjustment or modification, at his own cost and to satisfy the requirements of Integrated Testing and Commissioning within such time as the Employer / Engineer may deem to be reasonable.

Statutory Requirements 7.12.5 The Contractor along with others shall carry out all statutory tests and trials, under the supervision of the Engineer, necessary for obtaining sanction of the competent authority for opening the system for public carriage of passengers.

8 TIME MANAGEMENT

Commencement of Works 8.1 The Contractor shall commence the Works on the date specified in the Letter of Acceptance or if no date is specified in the Letter of Acceptance, on the date specified in an instruction in writing to that effect from the Engineer (Notice to Proceed). Thereafter the Contractor shall proceed with due diligence, without delay, and in accordance with the programme or any revised or modified programme of the Works. Time will be the essence of Contract and time for Completion shall reckon from the date the Contractor is required to commence the Works under this Clause.

217

GENERAL CONDITIONS OF CONTRACT

The Contractor shall not commence the construction, manufacture or installation of the Works or of any part of the Works unless and until the Engineer has endorsed the relevant Working Drawings in accordance with the Employer's Requirements.

Time for Completion 8.2

Time is the essence of Contract and will remain so at all times during the pendency of the Contract including the extended period of Contract. The Contractor shall ensure defect free completion and passing of tests on the completion, including integrated testing wherever provided in the scope of Work and commissioning of the whole of the Works and/or parts thereof before the same is taken over by the Employer.

Delay 8.3

In case of delay on the part of the Contractor, the Contractor shall be liable to pay Liquidated Damages and any other compensation for the damages suffered by the Employer as per clause 8.5. This is without prejudice to the right of the Employer to rescind the Contract.

Failure or delay by the Employer or the Engineer, to hand over to the Contractor the Site necessary for execution of Works, or any part of the Works, or to give necessary notice to commence the Works, or to provide necessary Drawings or instructions or clarifications or to supply any material, Plant or Machinery, which under the Contract, is the responsibility of the Employer, shall in no way affect or vitiate the Contract or alter the character thereof; or entitle the Contractor to damages or compensation thereof but in any such case, the Engineer shall extend the time period for the completion of the Contract, as in his opinion is/are reasonable.

Extension of Time for Completion 8.4

Extension of Time 8.4.1

The Contractor may apply for an extension of the Time for Completion if the Work is or will be delayed either before or after the Time for Completion by any of the following causes:

- a. "Force Majeure" referred to in Clause 16
- b. The Contractor's work held up for not being given possession of or access to the Site in accordance with the Contract
- c. Instruction of the Engineer to suspend the Works and the Contractor not being in default as to reasons of suspension.
- d. Acts or omissions of other Designated Contractors in executing Work not forming part of this Contract and on whose performance, the performance of the Contractor necessarily depends.
- e. Any act of prevention or Breach of Contract by the Employer and not mentioned in this Clause
- f. Any order of Court restraining the performance of the Contract in full or in any part thereof
- g. Any other event or occurrence which, according to the Employer is not due to the Contractor's failure or fault, and is beyond his control without Employer being responsible for the same.
- h. An Employer's Variation

However, the Contractor shall not be entitled to any extension of time where the instructions or acts of the Employer or the Engineer are necessitated by or intended to cure any default of or breach of Contract by the Contractor or where any delay is due to

GENERAL CONDITIONS OF CONTRACT

- a. the failure of Sub-contractor, to commence or to carry out Work in due time,
- b. non-availability, or shortage of Contractor's equipment, labour, utility services, Plant and Materials,
- c. inclement weather conditions, and
- d. the Contractor not fulfilling his obligations under Sub-clause 4.4.

If the Contractor considers himself to be entitled to an extension of time for Completion, he shall give notice to the Engineer of such intention as soon as possible and in any event within 28 days of the start of the event giving rise to the delay and full and final supporting details of his application within 21 days of the last day of delay, together with any notice required by the Contract and relevant to such Clause.

The Engineer shall proceed in accordance with Sub-clause 3.5 to agree or determine either prospectively or retrospectively such extension of the Time for Completion as may be due. The Engineer shall notify the Contractor accordingly. The extension of time including that of key date shall not entitle the Contractor to retain the Advances which shall be governed by Clause 11.2.

Extension of time for completion for other reasons 8.4.2

The Contractor shall not be entitled to an extension of time by reason of any delay to any activity in carrying out of the Works unless in the opinion of the Engineer such delay results in or may be expected to result in a delay to completion of the Works, or achievement of any Stage by the relevant Key Date. Whether or not the Contractor fails to achieve any Milestone by reason of any delay shall not by itself be material to the Contractor's entitlement to an extension of time.

Any extension to a Key Date shall not by itself entitle the Contractor to an extension to any other Key Date.

Extension of time for delays due to Contractor 8.4.3

If the delay in the completion of the whole Works or in achieving Key Date for stages of Work defined in Contract, for which an earlier completion period is stipulated, is due to the Contractor's failure or fault, and the Engineer is of the view that the remaining Works or subsequent linked Key Date for remaining stages of Work can be completed by the Contractor in a reasonable and acceptable short time, then, the Engineer may allow the Contractor extension or further extension of time at its discretion with or without Liquidated Damages, or with or without freezing of escalation indices in Price Variation formula, for completion, as he may decide.

Liquidated Damages for Delay 8.5

Time is the essence of the Contract. Appendix-1 to the Form of Tender shall include in respect of the Works and in respect of any Stage, a percentage of the total Contract value which will be recoverable from the Contractor as Liquidated Damages for delay in completion of the Works or in achievement of a stage by a particular Key Date. The total amount of Liquidated Damages in respect of the Works in all stages shall, however, not exceed the limit of Liquidated Damages stated in the Appendix to the Form of Tender. The aforesaid Liquidated Damages do not, however, include the sums payable by the Employer to Designated Contractors on account of delay caused by the Contractor to Designated Contractors. Such sums shall be recoverable from the Contractor in addition to any Liquidated Damages payable under this clause, the total ceiling limit of which is 15% of the Contract value including Liquidated Damages levied under the provision of Appendix 1 to the Form of

215

GENERAL CONDITIONS OF CONTRACT

Tender.

The Liquidated Damages are recovered by the Employer from the Contractor for delay and not as penalty. The Parties agree that amount of Liquidated Damages leviable under the Contract are the genuine pre-estimate of the loss suffered by the Employer because of which the Liquidated Damages have been levied on the Contractor. The Liquidated Damages may be recovered from any amount of money due from the Contractor under the Contract or any other Contract which the Contractor has with the Employer. The Liquidated Damages may also be recovered from the amount of Performance Security Bank Guarantee and in that case the Contractor would be liable to replenish the amount of Performance Security Bank Guarantee.

The Employer may, without prejudice to any other method of recovery, deduct the amount of such damages from any sum due, or to become due, to the Contractor. In the event of an extension of time being granted under Sub- Clause 8.3 and the amount due under this Sub-clause shall be recalculated accordingly, if excess recovery has been done, same will be refunded. The payment or deduction of such damages shall not relieve the Contractor from his obligations to complete the Works, or from any other of his duties, obligations or responsibilities under the Contract.

The Contractor shall use and continue to use his best endeavors to avoid or reduce further delay to the Works, or any relevant Stages.

At any time after the Employer has become entitled to Liquidated Damages, the Engineer may give notice to the Contractor under Sub-clause 13.1, requiring the Contractor to complete the Works within a specified reasonable time. Such action shall not prejudice the Employer's entitlements to recovery of Liquidated Damages, under this Sub-clause and to terminate under Sub-clause 13.2.

The decision of the Engineer as to the Liquidated Damages payable by the Contractor under this Clause shall be final and binding.

Rate of Progress 8.6

If for any reason which does not entitle the Contractor to an extension of time, the rate of progress of the Works is at any time, in the opinion of the Engineer, too slow to ensure timely completion of the Works or achievement of any Stage by the relevant Key Date, the Engineer may so notify the Contractor in writing. The Contractor shall thereupon take such steps as are necessary, or in default of taking such steps, shall take such steps as the Engineer may reasonably instruct in writing, to expedite progress so as to complete the Works or any Section in time or achieve any Stage by the relevant Key Date. The Contractor shall not be entitled to any additional payment for taking such steps.

If any steps taken by the Contractor in meeting his obligations under this Sub- Clause cause the Employer to incur additional costs, such costs shall be recoverable from the Contractor by the Employer, and shall be deducted by the Employer from any sum due, or to become due, to the Contractor.

If, in the opinion of the Engineer, the steps taken by the Contractor to expedite the progress are not adequate, the Engineer may take a recourse as per Clause 13.2.4 of this GCC.

Suspension of 8.7

The Engineer may at any time instruct the Contractor to suspend

GENERAL CONDITIONS OF CONTRACT

Work

progress of part or all of the Works. During suspension, the Contractor shall protect, store and secure such part or whole of the Works against any deterioration, loss or damage.

Consequences of Suspension 8.8

The Contractor shall not be entitled to extra cost (if any), incurred by him, during the period of suspension of Work., if such suspension is

- a. provided in the Contract, or
- b. necessary for proper execution of Woks or by reasons of weather condition or by some default on the part of the Contractor, or
- c. necessary for the safety of Works or any part thereof or
- d. necessary for the safety of adjoining public or other property or safety of the public or workmen or those who have to be at the site or
- e. to ensure safety and to avoid disruption of traffic and utilities, as also to permit fast repairs and restoration of any damaged utilities, or
- f. due to instructions of NGT/ EPCA or any other statutory authority on account of high pollution.

If suspension is ordered by the Engineer for reasons other than those mentioned in Sub-clause 8.8 then the Contractor's entitlement are in the table below:

Suspension Period	Extension of Time	Compensation for the suspension period	Remarks
Upto 14 days	No	No	Engineer may, at his sole discretion, give extension of time in exceptional circumstances.
15-30 days	Yes	No	Extension of time as considered proper by the Engineer
Above 30 days	Yes	<ul style="list-style-type: none"> • As per Daily rate of wages for idle labour/employees • 70% of the rate for hire charges/ equivalent hire charges for idle plant and machinery hired/owned (excluding cost of fuel and lubricants) • 15% above all these items to cover overhead costs. 	Compensation as assessed by the Engineer for entire suspension period on submission of documentary proof by the contractor to Engineer's satisfaction.
Above 90 days If contractor asks for fore closure	No	As per Clause 13.3.4	Contractor may ask for closure of the Contract, or deletion from the Contract of that part of Works which has been suspended.

Resumption of Work 8.9

After receipt of permission or of an instruction to proceed, the Contractor shall, after notice to the Engineer, and together with the Engineer, examine the Works, Plant, Rolling Stock and Materials affected by the

213

GENERAL CONDITIONS OF CONTRACT

suspension. The Contractor shall make good any deterioration or defect in or loss of the Works, Plant, Rolling Stock and Materials, which has occurred during the suspension.

9 EMPLOYER'S TAKING OVER

Taking Over Certificate

9.1 The Works shall be taken over by the Employer when they have been completed in accordance with the Contract, have passed the Tests on Completion, including Integrated Testing and Commissioning wherever applicable as per the Contract, and a Taking Over Certificate for the Works shall be issued. If the Works are divided into Sections, the Contractor shall be entitled to apply for a Taking Over Certificate for each Section.

The Contractor may apply by notice to the Engineer for a Taking-Over-Certificate not earlier than 14 days before the Works or Section (as the case may be) will, in the Contractor's opinion, be complete and ready for Taking Over. The Engineer shall, within 28 days after the receipt of the Contractor's application shall conduct a complete joint survey of the Works including carrying out any tests prescribed in the Contract and prepare a list of defects and outstanding Works and :

- a. issue the Taking Over Certificate to the Contractor, stating the date on which the Works or Section were completed, including the Tests on Completion and Integrated Testing and Commissioning wherever applicable as per the Contract in accordance with the Contract if defects and/or outstanding Works are minor that does not affect the use and safety of the Works or Section for their intended purposes. The list of such Works alongwith the target date of completion for each Work shall be enclosed with the Taking Over Certificate and completion of all these Works / Rectification of defects within the stipulated time shall be the responsibility of the Contractor and any failure in it may be considered a reason by the Engineer to cancel the Taking Over Certificate issued earlier; or
- b. reject the application, giving his reasons and specifying the Work required to be done by the Contractor to enable the Taking Over Certificate to be issued. The Contractor shall then complete such Work before issuing a further notice under this Sub-clause.
- c. Issue of Taking Over Certificate by the Employer would not absolve Contractor from any liability under the Law and Contract, arising from any hidden / latent defect in the Works / Section executed under the Contract by the Contractor. The Employer would be entitled to recover from the Contractor any compensation / damages / loss arising from such hidden / latent defect in the Works executed by the Contractor.

Taking over of Parts of the Works

9.2 The Engineer may, at the sole discretion of the Employer issue a Taking Over Certificate for any part of the Permanent Works by following the procedure stipulated in Clause 9.1 above if:

- a. the Employer uses thatpart of the Works for revenue service before the Taking Over Certificate is issued for the entire Work.
- b. the balance part is not completed, not due to the fault of the Contractor and contractual date of completion for the completed part is over.

10 DEFECTS LIABILITY

GENERAL CONDITIONS OF CONTRACT

Completion of Outstanding Work and Remedying Defects 10.1 "Defects Liability Period" shall mean the Defects Liability Period stated in the Special Conditions of Contract calculated from the date of taking over of the Works. Provided that, if any part of the Works or sub-systems or component of that part has been replaced, renewed or repaired except minor repair, the "Defects Liability Period" in respect of that part or sub-system or components of that part shall start from the date such replacement, renewal or repair has been completed to the satisfaction of the Engineer.

The expiry of Defect Liability Period would not absolve the Contractor from any liability under the Law and Contract arising from any hidden / latent defect in the Works / Section executed under the Contract by the Contractor. The Employer would be entitled to recover from the Contractor any compensation / damages / loss arising from such hidden / latent defect in the Works executed by the Contractor.

In order that the Construction and/or Manufacture Documents and the Works shall be in the condition required by the Contract (fair wear and tear excepted) at, or as soon as practicable after the expiry of the Contract Period, the Contractor shall execute all such Work of amendment, reconstruction, and remedying defects or damage, as may be instructed in writing by the Employer or the Engineer during the Defect Liability Period.

Cost of Remedying Defects 10.2 All Work referred to in Sub-clause 10.1 shall be executed by the Contractor at his own cost, if the necessity for such Work is due to:

- a. the design of the Works;
- b. Plant, Rolling Stock, Materials or workmanship not being in accordance with the Contract; or
- c. failure by the Contractor to comply with any of his other obligations.

If in the opinion of the Engineer, such necessity is due to any other cause, he shall determine an adjustment to the Contract Price, with the approval of the Employer, and shall notify the Contractor accordingly. In this event, Sub-clause 12.3 shall apply to such Work.

Extension of Contract Period 10.3 The Contract Period shall be extended by a period, after the Works are taken over, during which the Works or any Section or item of Plant, Rolling Stock, cannot be used, for the purposes for which they are intended, by reason of a defect or damage.

When delivery of Plant, Rolling Stock, and/or Materials, or erection of Plant, or installation of Materials, has been suspended under Sub-clause 8.7, the Contractor's obligations under this Sub-clause shall not apply to any defects or damage occurring more than three years after the Plant, Rolling Stock and/or Materials would otherwise have been delivered, erected and taken over.

Failure to Remedy Defects 10.4 If the Contractor fails to remedy any defect or damage within such time as the Employer / Engineer may deem to be reasonable, the Employer or the Engineer may fix a date on or by which to remedy the defect or damage, and give the Contractor reasonable notice of such date. If the Contractor fails to remedy the defect or damage by such date and the necessity for such Work is due to a cause stated in Sub-clause 10.2(a), (b) or (c), the Employer may (at his sole discretion):

211

GENERAL CONDITIONS OF CONTRACT

- a. carry out the Work himself or by others, in a reasonable manner and at the Contractor's risk and cost, but the Contractor shall have no responsibility for such Work: the costs incurred by the Employer in remedying the defect or damage shall be recoverable from the Contractor by the Employer;
- b. require the Engineer to determine and certify a reasonable reduction in the Contract Price; or
- c. if the defect or damage is such that the Employer has been deprived of substantially the whole of the benefit of the Works or parts of the Works, terminate the Contract in respect of such parts of the Works as cannot be put to the intended use, the Employer shall then be entitled to recover all sums paid for such parts of the Works together with the cost of dismantling the same, clearing the Site and returning Plant, Rolling Stock and Materials to the Contractor, and Sub-clause 13 shall not apply.

Notwithstanding anything contained herein the Employer would be entitled in urgent and critical situation(s)/events to remedy the defects in the Work by himself or through others, at the Contractor's risk and cost. The cost incurred by the Employer in remedying the defect or damage shall be recoverable from the Contractor by the Employer.

Removal of Defective Work 10.5 If the defect or damage is such that it cannot be remedied expeditiously on the Site and if the Employer gives consent, the Contractor may, remove from the Site for the purposes of repair any part of the Works, which is defective or damaged. This consent may require the Contractor to increase the amount of Performance Security by the full replacement cost of these items or to provide other appropriate Security acceptable to the Employer.

Further Tests 10.6 If the remedying of any defect or damage is such that it may affect the performance of the Works, the Engineer may require that Tests on Completion, including Integrated Testing, be repeated to the extent necessary. The requirement shall be made by notice within 28 days after the defect or damage is remedied. Such Tests shall be carried out in accordance with Clause 7.11

Right of Access 10.7 Until the Performance Certificate has been issued, the Contractor shall have the right of access to all parts of the Works and to records of the working and performance of the Works, except as may be inconsistent with any reasonable security restrictions by the organisation responsible for operating the Works.

Contractor to Search 10.8 The Contractor shall, if required by the Engineer, search for the cause of any defect, under the direction of the Engineer. Unless the defect is one for which the Contractor is liable, the Cost of such search shall be added to the Contract Price.

Performance Certificate 10.9 The Contract shall not be considered to be completed until the Performance Certificate has been signed by the Engineer or authorized official of the Employer and delivered to the Contractor at the end of 'Defect Liability Period, stating the date on which the Contractor completed his obligations related to completion of works and rectification of defects during Defect Liability Period to the Engineer's satisfaction. Only the Performance Certificate shall be deemed to constitute approval of the Works.

Notwithstanding anything contained herein the Contractor would continue to remain liable to the Employer for any cost, loss, damage or

GENERAL CONDITIONS OF CONTRACT

compensation which arises from hidden or latent defect in the work executed by the Contractor under the Contract, even if such hidden and latent defects arise after the expiry of Defect Liability period or grant of Performance Certificate by the Employer under the Contract to the Contractor.

Unfulfilled Obligations

10.10 After the Performance Certificate has been issued, the Contractor and the Employer shall remain liable for the fulfilment of any obligation, which remains unperformed at that time. For the purposes of determining the nature and extent of any such obligation, the Contract shall be deemed to remain in force.

Emergency defect rectification

10.11 If any defect or damage is one requiring immediate attention from safety, environmental or operational viewpoint, the Engineer has the authority to proceed with rectification in any manner suitable and deduct such sums from the Contract Price.

11 CONTRACT PRICE AND PAYMENT

The Contract Price Inclusions/ Exclusions

11.1

11.1.1 (i) Unless otherwise stated in the Special Conditions of Contract, the Contract Price, subject to any adjustment thereto in accordance with the Contract, shall be all inclusive (including all taxes, duties, royalties etc.)

(ii) Nothing extra shall be payable over the quoted rates, notwithstanding any provision to the contrary in any law for the time being in force, save and except what is specifically provided in General or Special Conditions of Contract.

(iii) The reimbursement (as per this Sub-clause) of whatsoever nature shall be provided only for Permanent Works. No reimbursement (as per this Sub-clause) shall be provided for Temporary Works and fuel.

Maintaining Records and Availing Exemptions

11.1.2

(i) In the event of exemption of custom duties, GST (CGST/IGST/SGST etc.) or any other cess/levy being granted by the Government in respect of the Works, the benefit of the same shall be passed on to Employer. The Contractor shall therefore maintain meticulous records of all the taxes and duties paid and provide the same as and when required by the Employer, so that the Employer is able to avail the reimbursement for which NMRC may issue a procedure order separately. Alternatively, the Employer may direct the Contractor to get the reimbursements based on exemption certificates / government's order and it shall be obligatory on part of the Contractor to get the reimbursements from the statutory authorities and pass on the benefit to NMRC.

(ii) In case of Contractor's failure in availing the exemptions as stipulated above, the recovery of equivalent amount will be made from Contractor's dues.

Adjust in Contract Price

11.1.3

Adjustment in Contract price shall be done if a "Price Variation Formula" is given in the Special Conditions Of Contract otherwise it will be a fixed price contract.

Change in Taxes/Duty

11.1.4

The Contract Price shall not be adjusted to take into account any increase or decrease in cost resulting from any change in taxes, duties, levies from the last date of submission of the Tender to the completion date including the date of the extended period of Contract unless a

209
GENERAL CONDITIONS OF CONTRACT

contrary provision exists in Special Conditions of Contract.

Advances 11.2

Mobilisation Advance 11.2.1

a. Mobilization Advance shall be generally limited to 5% of Original Contract Value payable in two equal installments or as mentioned in the Special Conditions of Contract. The first installment shall be paid after mobilization has started and next installment shall be paid after satisfactory utilization of earlier installment.

b. Mobilization Advance shall be paid interest free against acceptable Bank Guarantee from a scheduled commercial bank in India. The value of Bank Guarantee taken towards security of "Mobilization Advance" shall be 110% of the Advance taken by the Contractor. The Contractor, once the 50% of Mobilization Advance has been recovered, shall have a one-time option to reduce the Bank Guarantee for the Mobilization Advance by the amount recovered.

Advance against Plant and Machinery 11.2.2

Plant and Machinery Advance shall generally be limited to 5% of Original Contract Value or as specified in Special Conditions of Contract. This Advance shall be paid interest free against acceptable Bank Guarantee from a scheduled commercial bank in India. The value of Bank Guarantee taken towards Security of "Plant & Machinery Advance" shall be 110% of the Advance taken by the Contractor. The Contractor, once the 50% of Plant & Machinery Advance has been recovered, shall have a one-time option to reduce the Bank Guarantee for the Plant & Machinery Advance by the amount recovered. This Advance is payable against Plant, Equipment and Machinery, provided the same have reached the site or in the case of new items meant specifically for the work, firm purchase order has been placed and the invoices received. The Advance will be given only if the Plant / Machinery has been purchased for this Contract and not for those which are already in the books of the Contractor. The Plant and Machinery shall be valued by the Engineer as follows:

(i) New Items : 80% of purchase price

(ii) Second hand items in working order : 80% of the depreciated value as assessed by the Engineer

(iii) Items valued at less than : not to be considered
Rs 5.00 lakh per unit

Written Request for Advances 11.2.3

a. All Advances as admissible, shall be payable only on Contractor's written request to the Employer.

b. No advance shall be given after 40% of the original Contract amount has been paid.

Recovery of Advances 11.2.4

a. The recovery of Advances shall commence when 20% of the Original Contract Value of the Work has been paid and it will be completed by the time, 85% of the Original Contract Value has been paid or the original completion date whichever is earlier. As far as possible, the recovery of Advances shall be limited to 30% of on-account bill.

b. The Contractor shall always have the option to have the recoveries commenced and/or completed earlier, and/or to have recoveries affected in instalments of higher amount and also to repay part or whole of the Advance by direct payment rather than through on-account Bills.

GENERAL CONDITIONS OF CONTRACT

c. In case the Contract is terminated due to default of the Contractor or rescinded / foreclosed, due to any other reason, the Contractor shall return the unrecovered amount of all Advances within 15 days of issue of notice of termination / rescission / foreclosure of the Contract and if the Contractor fails to do so due to any reason whatsoever, then interest at rate equal to State Bank of India's Marginal Cost of fund based Lending Rate (MCLR) applicable for the tenure of 01 year prevailing on the date of issue of notice of termination / rescission / foreclosure plus 3% Penal Interest per annum shall be charged on the unrecovered amount of such Advances from 16th day onwards compounded quarterly till the same is returned by the Contractor.

Interest in Case of Delay in Repayment of Advances 11.2.5

Should there be delay in the progress and completion of Work, as a result of which it is not possible to recover the Advances and interest thereon, before the date of completion stipulated in the Contract, then the interest to be charged from the Contractor on the remaining portion of the Advances beyond the original completion date specified in the Contract, shall be equal to State Bank of India's Marginal Cost of fund based Lending Rate (MCLR) applicable for the tenure of 01 year prevailing on the original completion date specified in the Contract plus 3% Penal Interest per annum.

Advances to be Used only for this Work. 11.2.6

The Advances shall be used by the Contractor strictly for the purpose of the Contract, and for the purpose for which they are paid. Under no circumstances, shall the Advances be diverted for other purposes. Any such diversion shall be construed as a breach of the Contract and the Contractor shall be asked to return the Advances at once and pay interest at 15% per annum till the Advances are recovered back from him. The Contractor shall return the Advances and pay the interest in one go without demur.

Employer retains the right for any other remedy prescribed for breach of Contract in this regard.

The Contractor, if required by the Engineer shall provide the details of utilization of Mobilization Advance.

Provisional Payment Against Material at Site 11.3

11.3.1

A provisional payment on account of main construction materials required for the Permanent Works, shall be paid on request of the Contractor after these materials are brought to Site, against an Indemnity Bond in a form acceptable to Employer is duly executed. The payment shall be limited to 80% of the actual value or assessed value of these materials and the total of such provisional payment on account of construction materials at a time shall be limited to three percent of Original Contract Value or likely average consumption of such materials for three months, whichever is less and at any time the total outstanding provisional payment against material at site shall not exceed four percent of the Original Contract Value. The valuation of the average consumption of such main construction materials shall be approved by the Engineer, whose decision shall be final. Materials which are of perishable nature should be adequately insured.

Written Request for Advances/ Provisional Payment against 11.3.2

The provisional payments as admissible, shall be payable only on Contractor's written request to the Employer/Engineer.

208

GENERAL CONDITIONS OF CONTRACT

Material at Site

Recovery of Advances/ Provisional Payment against Material at Site **11.3.3** In case of provisional payment against Materials, the amount consumed every month shall be recovered from the next month's on-account bill and the recovery to be completed in 3 monthly installments. In case recovery could not be made due to any reason, interest will be charged at the rate equal to State Bank of India's Marginal Cost of fund based Lending Rate (MCLR) applicable for tenure of 01 year prevailing on the due date of recovery..

Application for Interim Payment Certificates **11.4**

11.4.1 In case of 'Lump Sum' Contract with cost centre and Milestone payment, the fixed Lump Sum Price shall be apportioned by the Contractor amongst the various Cost Centers. The amount thus apportioned under each Cost Centre will be further apportioned amongst various Milestones with the approval of the Employer. The Contractor shall be entitled to submit to the Engineer requests for interim payments only upon the achievement of one or more of the Milestones described in the Cost Centre.

At the beginning of each month, the Engineer shall issue to the Contractor certificate in respect of each Milestone due to be achieved in the preceding month stating:

- (i) the date on which the Milestone was achieved; or
- (ii) the non-achievement of the Milestone.

The Contractor shall submit a statement in three copies to the Engineer at the beginning of each month, in a form approved by the Engineer, showing the amounts to which the Contractor is entitled, together with supporting documents, including Milestone Certificates. The statement shall include the following items, as applicable, which shall be expressed in the various currencies in which the Contract Price is payable, in the sequence listed:

- a. the amount due in respect of Milestones is certified by the Engineer as achieved under each Cost Centre;
- b. any amounts to be added and deducted for the Advance payments and recovery thereof;
- c. any other additions or deductions is due and approved by the Engineer in accordance with the Contract; and
- d. the deduction of the amounts certified in all previous Interim Payment Certificates.

The Contractor shall not submit more than one request for interim payment per month.

If any Milestone is not achieved by the end of the month in which it is scheduled to be achieved, the Engineer shall suspend the payment relating to the Cost Centre in which the Milestone is included.

Payments suspended under this Clause shall be resumed by being included in the next application for interim payment made after the Milestone is achieved.

11.4.2 In case of 'Lump Sum' or Item rate' Contracts with payment schedule, the Contractor shall be entitled to be paid from time to time, normally once in a calendar month, by way of 'on-account' bill as per the payment

GENERAL CONDITIONS OF CONTRACT

schedule indicated in Bill of Quantity(BOQ) or as finally approved by the Engineer.

Issue of Interim Payment Certificates 11.5

No amount will be certified or paid until the Employer has received, and approved, the Performance Security and the Parent Company Undertakings and Guarantees in accordance with Sub-clause 4.2 and signing of the Contract Agreement. Thereafter, the Engineer shall, within 21 days of receiving a statement and supporting documents, deliver to the Employer, with a copy to the Contractor, an Interim Payment Certificate showing the amount which the Engineer considers to be due; if no payment is considered to be due, the Engineer shall promptly notify the Contractor accordingly.

Where only a part of the payment applied for is disputed, payment certificate shall be issued for the undisputed amount.

The Engineer shall have the power to omit from any of the Contractor's requests for payment, the value of any Work executed or Materials supplied or Services rendered, with which he may for the time being be dissatisfied and for that purpose and for any other reason which to him may seem proper, may delete, correct or modify the sum(s) previously certified by him as being due to the Contractor.

Payment- Interim and Final 11.6

Unless otherwise stated in Special Conditions of Contract,

a. After preliminary scrutiny and certification by the Engineer, payment of 80% of the certified interim amount shall be made by the Employer within 07 days. The amount certified shall account for all deductions, including statutory deductions, recoveries for Advances and any amounts due from the Contractor. The balance 20% shall be paid within 28 days, from the date of the preliminary certification of the bill by the Engineer.

b. Next 80% interim payment shall be made only after 100% payment of preceding interim payment certified has been completed.

c. Any such payment made to Contractor by Employer, shall not constitute any acceptance of the measurements or bill of quantities by the Employer and the Employer shall have the right to alter, modify, reduce or diminish the quantities or classification entered in the measurement books or bills. The Employer shall have right to recover any excess payment made in either 80% interim payment of bill or earlier bill from balance 20% bill or subsequent bill respectively. However, if such excess payment exceeds the balance 20% bill or subsequent bill respectively, the Contractor shall on demand from the Engineer or Employer immediately refund the extra amount to the Employer within 7 days, failing which the Contractor shall have to pay interest at the rate equal to State Bank of India's Marginal Cost of fund based Lending Rate (MCLR) applicable for the tenure of 01 year prevailing on date plus 3% Penal interest per annum with monthly rest till the said extra amount is paid back by the Contractor.

d. The Employer shall pay the amount certified in the final payment certificate within 56 days from the date of issue of certificate.

Payments shall be made into a bank account, nominated by the Contractor in Indian rupees in a bank in India unless otherwise permitted in Special Conditions of Contract. If payments are to be made in more than one currency, separate bank accounts may be nominated by the contractor for each currency, and payment shall be made by the

[Handwritten signatures and initials in blue ink]

205

GENERAL CONDITIONS OF CONTRACT

- Employer accordingly.
- Statement at Completion** **11.7** Not later than 60 days after the issue of the Taking Over Certificate for the whole of Works, the Contractor shall submit, to the Engineer, three copies of a statement at completion with supporting documents, showing in detail, in the form approved by the Engineer under Sub-clause 11.4.:
- a. the final value of all Work done in accordance with the Contract, up to the date stated in such Taking Over Certificate,
 - b. any further sums which the Contractor considers to be due, and
 - c. an estimate of amounts which the Contractor considers will become due to him under the Contract.
- The estimated amounts shall be shown separately in such statement at completion. The Engineer shall certify payment under Sub-clause 11.5.
- Application for Final Payment Certificate** **11.8** Not later than 56 days after the issue of the Performance Certificate, the Contractor shall submit to the Engineer three copies of a draft final statement with supporting documents showing in detail, in a form approved by the Engineer:
- a. the value of all Work done in accordance with the Contract, and
 - b. any further sums which the Contractor considers to be due to him under the Contract or otherwise.
- If the Engineer disagrees with or cannot verify any part of the draft final statement, the Contractor shall submit such further information as the Engineer may reasonably require and shall make changes in the draft as may be agreed between them. The Contractor shall then prepare and submit to the Engineer the Final Statement as agreed.
- If, following discussions between the Engineer and the Contractor and any changes to the draft final statement which may be agreed between them, it becomes evident that a dispute exists, the Employer shall pay those parts of the draft final statement as certified by the Engineer as not being in dispute. The remainder of the dispute may then be resolved under Clause 17, in which case the Contractor shall then prepare and submit to the Engineer a Final Statement in accordance with the outcome of the dispute.
- Discharge** **11.9** When submitting the final statement, the Contractor shall submit a written discharge which confirms that the total of the Final Statement represents full and final settlement of all monies due to the Contractor under the Contract. Such discharge may state that it shall become effective only after payment due under the Final Payment Certificate has been made and the Performance Security referred to in Sub-clause 4.2 has been returned to the Contractor.
- Issue of Final Payment Certificate** **11.10** The Engineer shall issue to the Employer, with a copy to the Contractor, the Final Payment Certificate within 28 days after receiving the Final Statement and written discharge in accordance with Sub-clause 11.8 and 11.9 respectively, stating:
- a. the amount which is finally due, and
 - b. after giving credit to the Employer for all amounts previously paid by the Employer and for all sums to which the Employer is entitled, the balance, if any, due from the Employer to the Contractor or from the

GENERAL CONDITIONS OF CONTRACT

Contractor to the Employer, as the case may be.

If the Contractor has not applied for a Final Payment Certificate in accordance with Sub-clauses 11.8 and 11.9, the Engineer shall request the Contractor to do so. If the Contractor fails to make such an application within a period of 28 days, the Engineer shall issue the Final Payment Certificate for such amount as he considers to be due.

Notwithstanding anything contained herein the issue of Final Payment Certificate would not restrict/hinder the right of the Employer in Law/under the Contract to recover from the Contractor in loss, damage, compensation arising out of fraudulent practice/corrupt practices indulged into by the Contractor prior to the execution of the Contract, during the execution of the Contract and after the completion of the Contract.

Notwithstanding anything contained herein, the issue of Final Payment Certificate would not absolve the Contractor from any liability/loss/damage/ compensation towards the Employer in Law and/or under the Contract arising out of latent and hidden defects in the Works executed by the Contractor under the Contract.

Cessation of Employer's Liability	11.11	In respect of any matter or thing arising out of (or in connection with) the Contract or execution of the Works before the issue of the Taking Over Certificate for the whole of the Works, the Employer shall not be liable to the Contractor unless the Contractor shall have included a claim for it in his Statement at Completion described in Sub-clause 11.7. For any such matter or thing arising after the issue of the Taking Over Certificate for the whole of the Works, the Employer shall not be liable to the Contractor unless the Contractor shall have included a claim for it in his Final Statement.
Calculation of Payments in Foreign Currency	11.12	All payments made by the Employer pursuant to the terms of the Contract shall be in the currency or currencies specified in the Contract. Wherever any sum in a foreign currency has to be converted into Indian Rupees for any purpose, the exchange rate to be employed for such conversion shall be the selling rate of exchange at the close of business of the State Bank of India, 28 days before the latest date of submission of Tenders.
Round off	11.13	In every payment to the Contractor, sums of less than fifty paise shall be omitted and sums of fifty paise and more up to one rupee shall be reckoned as one rupee.
Payment By Cheque and E-Payment	11.14	All payments to the Contractor will be made by cheque or "E-Payment" as desired by the Employer.
Tax Deduction at Source	11.15	Tax deductions will be made at source as per statutory requirement from every payment made to the Contractor at rates notified from time to time.
Production of Vouchers	11.16	i. The Contractor shall, whenever required by the Engineer, produce or cause to be produced for examination by the Engineer, any quotation, invoice, cost or other account books, vouchers, receipts, letters, memoranda or any copy of or extract from any such documents and also furnish information and returns, as may be required, relating to the execution of this Contract or relevant for verifying or ascertaining the cost of execution of this Contract or ascertaining the Materials supplied by the Contractor are in accordance with the Specifications laid down in the Contract. The Engineer's decision on the question of relevancy of

203

GENERAL CONDITIONS OF CONTRACT

any documents, information or returns shall be final and binding on the Parties.

i. If any part or item of the Work is allowed to be carried out by a Sub- contractor, assignee or any subsidiary or allied Firm, the Engineer shall have power to secure the books of such Sub-contractor, assignee or any subsidiary or allied Firm through the Contractor, and shall have power to examine and inspect the same. The above obligations are without prejudice to the obligations of the Contractor under any statute, rules or orders.

Withholding and Lien for Sums Claimed 11.17

i. The Employer shall have lien over all or any moneys that may become due and payable to the Contractor under the Contract, and/or over the deposit of Performance Security or other amount or amounts made under the Contract and which may become payable to the Contractor.

i. And further, unless the Contractor pays and clears immediately on demand any claim of the Employer, the Employer shall at all times be entitled to deduct the amount of the said claim from the moneys, securities and / or deposits which may have become or will become payable to the Contractor under the presents, or under any other Contract or transaction whatsoever between the Employer and the Contractor even if the matter stands referred to Arbitration. The Contractor shall have no claim for any interest or damage whatsoever in respect of any amounts withheld or treated as withheld under the lien referred to above and duly notified as such to the Contractor.

Signature on Receipts for Payments 11.18

Every receipt of payment to Contractor including refund of the Performance Security shall be signed by the person authorized to do so on his behalf. In the event of death of any of the Contractor's partners in case the Contractor is a partnership firm, during the currency of the Contract, it is hereby expressly agreed that every receipt by any one of surviving Contractor's partners, shall, if so signed as aforesaid, be a good and sufficient discharge as aforesaid, provided that nothing in this Clause shall be deemed to prejudice or affect any claim, which the Employer may hereafter have against the legal representatives of any Contractor's partner so dying, for or in respect of breach of any of the conditions of the Contract. Provided also that nothing contained in this clause shall be deemed to prejudice or affect the respective rights and obligations of the Contractor's partners, or of the legal heirs / representatives of any deceased Contractor / partner interest.

Post Payment Audit 11.19

It is an agreed term of the Contract, that the Employer reserves to himself the right to carry out a post payment audit and / or technical examination of the Works, and the Final bill including all supporting vouchers, abstracts, etc., and to make a claim on the Contractor for the refund of any excess amount paid to him, If as a result of such examination, any over-payment to him is discovered to have been made in respect of any Work done or alleged to have been done by the Contractor, under the Contract. If any under-payment is discovered, the same shall be paid by the Employer to the Contractor. Such payments or recoveries, however, shall not carry any interest.

Recovery of money due to the Employer 11.20

All damages (including, without limitation, Liquidated Damages), costs, charges, expenses, debts, or sums for which the Contractor is liable to the Employer under any provision of the Contract may be deducted by the Employer from monies due to the Contractor under the Contract

GENERAL CONDITIONS OF CONTRACT

(including, without limitation, Liquidated Damages) and the Employer shall have the power to recover any balance not so deducted from monies due to the Contractor under any other Contract between the Employer and the Contractor.

When the Contractor has as per the provision of the Contract assigned to a third Party the right to receive monies due, or, to become due, under the Contract to the Contractor or charged such monies in favour of a third Party, the Employer's right to deduct damages (including without limitation Liquidated Damages), costs, charges, expenses, debts or sums for which the Contractor is liable to the Employer from monies due to the Contractor under the Contract shall be limited to the right expressed above.

12 VARIATIONS

Right to Vary 12.1

All Variations shall be recorded in a written instruction from the Engineer either as a Contractor's Variation or as an Employer's Variation, and shall not be implemented by the Contractor without such an instruction in writing from the Engineer. No Variation shall in any way vitiate or invalidate the Contract. The Contractor shall not make any alteration and/or modification of the Works, unless and until the Engineer instructs or gives consent to a Variation. If the Construction and/or Manufacture Documents or Works are not in accordance with the Contract, the rectification shall not constitute a Variation.

Contractor's Variations 12.2

Variation Proposals 12.2.1

The Contractor may submit to the Employer, in writing at its own cost, any engineering proposal as Contractor's Variation for modifying the Employer's Requirements, provision of additional land, access or feasibility over and above that is provided in the Contract for the purpose of saving in time, construction or manufacture costs. Such Variation proposal shall not impair the essential character, functions or characteristics or the Work, including Service life, economy of operation, ease of maintenance, desired appearance, or design and safety standards.

The Contractor shall provide his Variation proposal in a time limit prescribed by the Engineer. The Engineer's decision in this regard shall be communicated to the Contractor within a reasonable period of time. If by any reason, the time limit specified by the Engineer is exceeded, the proposal may not be considered.

The decision of the Engineer in this regard shall be final and binding.

Contents of Variation 12.2.2

If the Employer requires or accepts it, and if the Contractor wants to proceed with the proposal, the Contractor must provide (at no cost to the Employer) a detailed report prepared by a Consultant acceptable to the Employer and which shall include:

- a. a general description of the original Contract requirements for the Works and the proposed changes
- b. a detail of all the proposed modifications to the drawings and specifications
- c. a detail of all Work and goods affected by the value engineering proposal
- d. a detailed estimate of the construction cost based on the original

201

GENERAL CONDITIONS OF CONTRACT

Contract requirements and based on the proposed changes

e. any resultant time extensions or reductions for the Contract

f. statement to the extent of minimum saving expected. The Contractor's cost of preparing the Variation proposal shall be excluded in determining the estimated net savings in construction costs.

Employer Review 12.2.3

The Employer may in his sole discretion, accept or reject the Contractor's Variation or any part thereof and determine the estimated net saving in the construction cost. The Employer shall not be liable for delays or damages to the Contractor due to any failure of the Employer to accept or act upon any such Variation proposal submitted pursuant to this Clause.

Once, the Employer or the Engineer rejects the Contractor's Variation during proposition due to any reason, it shall not be pursued by Contractor in any other form.

Amendments- Employer Issuance 12.2.4

If the Variation proposal is acceptable to the Employer/Engineer in whole or in parts, it will be accepted by execution of an amendment or by communication in writing. Such amendment/communication in writing shall identify all the changes in the specifications, Contract Period etc. and shall specify net savings on construction costs which shall be adjusted in the Contract value by the Employer.

Contractor's Acceptance and Payment 12.2.5

The Contractor shall either accept or reject any proposed amendment/communication in writing executed by the Engineer pursuant to this section within 5 working days of its receipt date from the Employer. If the Contractor does not reject the same in the period stipulated above, the amendments /communication in writing shall be deemed to be accepted by the Contractor and shall become a Variation to the Contract. The Contractor's acceptance shall be unconditional and the Contract value / price shall be adjusted by the amount of saving due to the Variation.

Employer's Variations 12.3

If the Engineer requests a proposal, prior to instructing a Variation which may be for additional work or alteration in the work on deletion / reduction in the scope of work, the Contractor shall submit at his own cost within 14 days or such period as the Engineer may allow of the receipt of such request of the Engineer

a. a description of the proposed design and/or work to be performed and a programme for its execution,

b. the Contractor's proposal for any necessary modifications to the programme according to Sub-clause 4.13, and

c. the Contractor's proposal for adjustment to the Contract Price, Time for Completion and/or modifications to the Contract.

Variation Procedure 12.1

The Engineer shall, as soon as practicable after receipt of proposals under sub- clauses 12.2 and / or 12.3, respond with approval, rejection or comments.

If the Engineer instructs or approves a Variation, he shall proceed in accordance with Sub-clause 3.5 to agree or determine adjustments to the Contract Price, Time for Completion and Schedule of Payments.

After receipt of proposal, it will be the prerogative of the Employer, whether to Instruct and proceed ahead with the Variation or drop the proposal in part or full. In that case, no cost of preparing and submitting the proposal will be payable to Contractor. In case, the design part of

GENERAL CONDITIONS OF CONTRACT

Variation in the Bill of Quantities 12.5

Variation has been completed on submission of same to the Engineer, the Employer decides to abandon the Variation, only cost for design to the extent of work done will be paid to the Contractor.

Clause 12.5 - Variation in the Bill of Quantities

This sub clause shall be applicable to Schedules of measurement Contracts. This clause shall also be applicable to item rates / Provisional Sum Schedules of Lump-Sum Contracts

The quantities of items and /or Provisional Sum, shown in different Schedules of BOQ are approximate, and liable to vary during the actual execution of the work. Some items may have to be added or deleted. The Contractor shall be bound to carry out and complete the stipulated Work as instructed by the Engineer, irrespective of the magnitude of variations including additions or deletion in the Bill of Quantities. Variations shall be paid as follows:

- i. Schedules having items rates with quantities :
 - a. At the accepted rates of the Contract for Positive variation in quantities of items to the extent of 25%. In case of variation in quantities on minus side, Contract rates will be payable at the accepted rates of the Contract for the executed quantities.
 - b. In case the Variation in individual items (except for items under Para c), d) & e) below) as stipulated above: is more than 25% on plus side, the rate for the varied quantity beyond 25% shall benegotiated between the Engineer and the Contractor and mutually agreed rates arrived at before execution of the extra quantity.
 - c. In case of earth work, the aforesaid Variation limit of 25% shall apply to the gross quantity of earth work and Variation in the quantity of individual classifications of soil will not be subject to this limit where any Variation can take place.
 - d. In case of foundation work, no Variation limit applies and Contractor shall carry out the Work, at the accepted rates of the Contract irrespective of any Variation.
 - e. Variation in the quantity of items individually costing upto 1% of total Original Contract Value or `50 lakh, whichever is less, shall be payable at the accepted rates of the Contract, till the value of such individual item on account of Variation reaches upto 2% of the total Original Contract Value or `1 crore, whichever is less. Negotiation of rates for such items shall be conducted only for the exceeded quantity beyond 2% of the Original Contract Value or `1 crore, whichever is less.
- i. Schedules having Provisional Sum (containing only rates of items but without quantities) / Items having Provisional Sum (e.g. referring to Standard Schedules of Rates etc.):
 - a. At the accepted rates of the Contract for Positive Variation in Provisional Sum to the extent of 25%. In case of Variation in Provisional Sum on minus side, Contract rates will be payable at the accepted rates of the Contract for the executed quantities.
 - b. In case the Variation in Provisional Sum as stipulated above: is more than 25% on plus side, the rate for works under item A.(ii) beyond 25% Variation in Provisional Sum shall be negotiated between the Engineer and the Contractor and mutually agreed rates arrived at, before

199

GENERAL CONDITIONS OF CONTRACT

its execution.

B. Deriving Rates For New Items / Negotiation

C. This Sub-clause shall be applicable to all Schedules of BOQ including Lump-Sum Schedule.

i. In case Engineer introduces an item for which the Contract does not contain any rates or prices applicable to the varied Works, the rate of such items shall be derived, wherever possible, from rate for similar items available in the Bill of Quantities of the accepted Tender. In case this is not possible, the rate may be decided on the following basis:

a. Cost of Materials at current market price, as actually utilised in the final finished Permanent Works, including a reasonable percentage for wastage and transportation.

b. Cost of enabling works if any (unless provided for separately) worked out on the above basis but with less stringent quality. Specifications minus salvage value of serviceable material released after completion of Work and cost of material released as scrap.

c. Cost of labour actually used at the site of Work at rates under Payment of Minimum Wages Act for the area of Work for each category of worker, further enhanced by a percentage of 10% of the aforesaid rates to account for labour not directly utilised at Site and other ancillary and incidental expenses on labour.

d. Hire charges for Plant & Machinery, scaffolding, shuttering, forms, etc., required to be used at the site of the work. The tools used by the various trades shall not be counted as Plant & Machinery for this purpose.

e. An amount of 20% of items B.(i) a), b), c) and d) above to allow for Contractor's overheads including water/electricity charges and labour cess etc., profits and corporate taxes etc. No such percentage shall be applicable to the estimated cost of Materials supplied free of cost to the Contractor.

f. In all cases where extra items of Work are involved, for which there are no rates in the accepted Bill of Quantities, the Contractor shall give a notice to the Engineer, of at least 7 days before the need for its execution arises.

In the event of disagreement in respect of items A (i) b), A (i) e), A (ii) b) and B (i) above, the Engineer shall fix such rates of price as are, in his opinion appropriate and shall notify the Contractor accordingly, with a copy to the Employer. Until such time as rates or prices are agreed or fixed, the Engineer shall determine provisional rates or prices to enable on-account payments to the Contractor. Alternatively, in the event of disagreement, the Contractor shall have no claim to execute extra quantities/new items and the Engineer shall be free to get such additional quantities beyond 25%/new items executed through any other Agency. However, if the Engineer or the Employer so directs the Contractor shall be bound to carry out any such additional quantities beyond the limits stated above original quantities and/or new items and the disagreement or the difference regarding rates to be paid for the same shall be settled in the manner laid down under the conditions for the settlement of dispute.

Payment in

12.6

If the Contract provides for payment of the Contract Price in more than

GENERAL CONDITIONS OF CONTRACT

Applicable Currencies one currency, and an adjustment is agreed or fixed as stated above, the amount payable in each of the applicable currencies shall be specified when the adjustment is agreed or fixed. In specifying the amount in each currency, the Contractor and the Engineer (or, failing agreement, the Engineer) shall take account of the actual or expected currency proportions of the Cost of the varied Work, without being bound by the proportions of various currencies specified for payment of the Contract Price.

13 TERMINATION OF THE CONTRACT

Notice to Contractor 13.1 If the Contractor fails to carry out any of his obligations, or if the Contractor is not executing the Works in accordance with the Contract, the Engineer may give notice to the Contractor requiring him to make good such failure and remedy the same within such time as the Employer / Engineer may deem to be reasonable.

Termination of Contract Due to Contractor's Default 13.2

Conditions Leading to termination of Contract 13.2.1 The Employer shall be entitled to terminate the Contract if the Contractor or any one of its constituents,

- a. fails to comply with a notice under Sub-clause 13.1
- b. abandons or repudiates the Contract
- c. without reasonable excuse acceptable to the Engineer, fails to commence the Works in accordance with the Contract
- d. Sub-contracts the whole of the Works or assigns the Contract without approval of the Employer
- e. becomes bankrupt or insolvent or goes into liquidation except voluntary liquidation for the purpose of amalgamation or reconstruction
- f. persistently disregards instructions of the Engineer or contravenes any provisions of the Contract, or
- g. fails to adhere to the agreed programme of work by margin of 10% of the stipulated period or 21 days, whichever is earlier, or fails to complete the Works or parts of the Works within the stipulated or extended period of completion, or is unlikely to complete the whole Work or part thereof within time because of poor record of progress; or
- h. fails to remove materials from the Site, or pull down and replace Work, after receiving notice from the Engineer to the effect that the said materials or Works have been condemned or rejected, or
- i. fails to take steps to employ competent and/or additional staff and labour, or
- j. fails to afford the Engineer or his Representative proper facilities for inspecting the Works or any part thereof, or
- k. indulges in corrupt or fraudulent practices as explained in Clause 4.33

13.2.2 In any one of these events or circumstances, the Employer may upon giving 14 days notice to the Contractor, terminate the Contract and expel the Contractor from the Site. However, in case of sub-paragraph (e) or (k), the Employer may by notice of 7 days to the Contractor, terminate the Contract immediately.

197

GENERAL CONDITIONS OF CONTRACT

13.2.3 For the purpose of sub-para (c) above, of this clause, reasonable excuse shall be the one, which in the opinion of the Engineer has resulted from, any circumstance which

- is beyond the Employer's or Contractor's control and
- made the failure unavoidable and it is evidenced by the Contractor to the satisfaction of the Engineer that the failure was remedied without unreasonable delay once that obstacle was out of the way.

13.2.4 In case of Sub-para(g), the Engineer at its sole discretion may terminate only part of the Contract also by taking out some part of the total scope of Work and may get it completed or arranged from any other entity through the process of Open/Limited/Single Tender or by calling quotations, to do so at the risk and cost of the Contractor.

13.2.5 The Employer's decision to terminate the Contract shall not prejudice any other rights of the Employer under the Contract.

13.2.6 On termination of Contract due to Contractor's default, the Performance Security shall be forfeited by encashing the Bank Guarantee and the balance Work shall be got done independently without risk and cost of the failed Contractor. The failed Contractor shall be debarred from participating in the Tender for executing the balance Work. If the failed Contractor is a JV/Consortium or a partnership Firm, then every member/partner of such JV/Consortium or partnership Firm shall be debarred from participating in the Tender for the balance Work either in his/her individual capacity or as a partner of any other JV/Consortium or partnership Firm.

13.2.7 The Engineer shall not make a claim under the Performance Security except for amounts to which the NMRC is entitled under the Contract (Not withstanding and/or without prejudice to any other provisions in the Contract Agreement) in the event of:

- i. Failure by the Contractor to extend the validity of the Performance Security as described herein above, in which event the Engineer may claim the full amount of the Performance Security.
- i. Failure by the Contractor to pay NMRC any amount due, either as agreed by the Contractor or determined under any or the Clauses/Conditions of the Agreement, within 30 days of the service of notice to this effect by Engineer.
- i. The Contractor being determined or rescinded under provision of the GCC in which event, the Performance Security shall be forfeited in full and shall be absolutely at the disposal of the NMRC.

Valuation at the date of Termination

13.2.8 The Engineer shall, as soon as possible after termination under Sub-clause 13.2.1, determine and advise the Contractor of the value of the Construction and/or Manufacture Documents, Plant, Rolling Stock, Materials, Contractor's Equipment and Works and all sums then due to the Contractor as at the date of termination.

Payment after Termination

13.2.9 After termination under Sub-clause 13.2.1, the Employer shall not be liable to make any further payments to the Contractor until the costs of design, manufacture, execution, completion and remedying of any defects, damages for delay in completion (if any), and all other costs incurred by the Employer, have been established and recovered..

The Employer shall be entitled to recover from the Contractor the extra costs, if any, of completing the Works after allowing for any sum due to the Contractor under Sub-clause 13.2.8. If there are no such extra costs,

GENERAL CONDITIONS OF CONTRACT

the Employer shall pay any balance to the Contractor.

Non-exercise of power not to constitute waiver 13.2.10 Provided always that in case any of the powers conferred upon the Employer by Sub-clause 13.1 and Sub-clause 13.2.1 above, shall have become exercisable, and the same may not have been exercised, the non-exercise thereof shall not constitute waiver of any of the conditions thereof.

Default of Employer 13.3

Notice by Contractor 13.3.1 In the event of the Employer:

- a. failing to pay the Contractor, without reasonable cause, the certified amount due under any certificate of the Engineer within 56 days after the expiry of the time stated in Sub-clause 11.56 within which payment has to be made, subject to any deduction that the Employer is entitled to make under the Contract, or
- b. becoming bankrupt or, being a Company, going into liquidation, other than for the purpose of a scheme of reconstruction or amalgamation,

then, the Contractor may give notice requiring the Employer to remedy the default within 28 days after receipt of the notice. If the Employer fails to remedy the default or fails to propose steps reasonably acceptable to the Contractor to do so and in that case, the Contractor may terminate the Contract after issue of 14 days notice to the Employer with a copy to the Engineer. In this case, the Contractor shall be compensated as per Sub clause 13.3.4

The Engineer's decision on the certified amount payable on this account shall be final and binding.

Contractor's Entitlement to Suspend the Work 13.3.2 The Contractor may, if the Employer fails to pay the Contractor the certified amount due under any certificate of the Engineer within 56 days after the expiry of the time stated in Sub-clause 11.6, within which payment is to be made, subject to any deduction that the Employer is entitled to make under the Contract, after giving 28 days' prior notice to the Employer, with a copy to the Engineer, suspend Work or reduce the rate of progress of Work.

If the Contractor suspends Work or reduces the rate of progress of Work in accordance with the provisions of this Sub-clause and thereby suffers delay or incurs costs the Engineer shall, after due consultation with the Employer and the Contractor, determine:

- a. any extension of time to which the Contractor is entitled under Sub-clause 8.4, and
- b. the amount of such costs, which shall be added to the Contract Price, and shall notify the Contractor accordingly, with a copy to the Employer.

Cessation of Work by Contractor 13.3.3 After termination under Sub-clause 13.3.1, the Contractor shall:

- a. cease all further Work, except for such Work as may be necessary and instructed by the Engineer for the purpose of making safe or protecting those parts of the Works already executed, and any Work required to leave the Site in a clean and safe condition,
- b. hand over all Construction and/or Manufacture Documents, Plant, Rolling stock, and Materials for which the Contractor has received

195

GENERAL CONDITIONS OF CONTRACT

payment,

c. hand over those parts of other Works executed by the Contractor up to the date of termination, and

d. remove all Contractor's Equipment if not required by the Employer which is on the Site and repatriate all his staff and labour from the Site.

Any such termination shall be without prejudice to any other right of the Contractor under the Contract.

Payment on Termination

13.3.4

After termination under Sub-clause 13.3.1, the Employer shall return the Performance Security, if not invoked and shall pay the Contractor an amount calculated and certified in accordance with the following conditions:.

a. The value of approved materials actually brought to the site and reasonably required to execute the Works during next three months, as per approved Programme, and

b. Value of Work completed up to date by the Contractor at rates specified in the Contract, after taking into account any deductions, retentions, setoff, Damages, compensation, loss payable to Employer etc.

c. In addition, a sum not exceeding 2% (two percent) of the value of the work remaining incomplete on the date of Termination notice taking effect.

The payment as above shall be the full compensation for termination under this Clause and the Contractor shall have no claim for damages or other entitlements whether under the Contract or otherwise.

13.3.5

In case termination/foreclosure of the Contract under whatsoever circumstances, any remaining Tools, Plants, Equipments and surplus materials of Employer with Contractor will be returned to the Employer in good condition at Employer's depot at Contractor's cost. In case of the failure of the Contractor to do so, the Employer will be entitled to recover their cost from the Contractor from the amount becoming due to the Contractor or from any other money due in any other Contracts. The decision of the Engineer of the amount to be recovered will be final and full credit at rates initially charged to the Contractor shall be allowed for such materials. Similarly the Employer shall be entitled to recover the cost of the unreturned material, Plant, Equipment and Tools from the Contractor where such material have been supplied free of cost or on lease basis to the Contractor as stipulated in the Conditions of Contract.

14

RISK AND RESPONSIBILITY

Indemnity

14.1

The Contractor shall indemnify and hold harmless the Employer, the Engineer, the Designated Contractors, Representatives and employees from and against all actions, suits, proceedings, claims, damages, losses, expenses and demands of every nature and description, by reasons of any act or omissions of the Contractor, his Representative or his employees in the execution of the Works, including professional services provided by the Contractor or in the guarding the same.

These indemnification obligations shall include but not be limited to claims, damages, losses, damage proceedings, charges and expenses which are attributable to:

GENERAL CONDITIONS OF CONTRACT

- a. sickness, or disease, or death of, or injury to any person; and
- b. loss of, or damage to, or destruction of any property (other than the Works) including consequential loss of use; and
- c. loss, damage or costs arising from the carriage of Plant, Rolling Stock and Materials and/or ownership or chartering of marine vessels by the Contractor, or any Sub-contractor of any tier.

The Contractor shall also indemnify and save harmless the Employer from and against all claims and proceedings on account of infringements of patents rights, design, trademark name etc as detailed out in clause 5.8.

All sums payable by way of compensation under these conditions shall be considered reasonable compensation payable to the Employer, without reference to the actual loss or damage sustained, and whether or not any damage shall have been sustained. The decision of the Engineer as to compensation claimed shall be final and binding.

Contractor's Care of the Works

14.2

The Contractor shall take full responsibility for the care of the Works, or any part thereof, including full responsibility for the care of any Work being manufactured, or stored off-Site for inclusion in the Works, or in the course of transportation to the Site, and for the care of Contractor's Equipment, Temporary Works, Plant, Rolling Stock, and any other Material, whatsoever, on the Site or delivered to or placed on the Site in connection with, or for the purpose of the Works.

The Contractor shall take this responsibility from the Commencement Date until the date of issue of the Taking Over Certificate, when responsibility shall pass to the Employer. If the Engineer issues a Taking Over Certificate for any Section or part of the Works, the Contractor shall cease to be responsible for the care of that Section or part from the date of issue of such Taking Over Certificate when responsibility shall pass to the Employer.

The Contractor shall take responsibility for the care of any outstanding Work which is required to be completed prior to the expiry of the Contract Period, until the Engineer confirms in writing that such outstanding Work has been completed.

If any loss or damage happens to the Works, any other property or person, arising from any cause other than the Employer's risks listed in Sub-clause 14.3, during the period for which the Contractor is responsible, the Contractor shall rectify such loss or damage, at his cost, so that the Works conform with the Contract or at the option of the Employer, will pay or allow to the Employer the cost of rectifying such loss or damage. Notwithstanding such loss or damage, the Contractor shall proceed with the execution of Works in all respects in accordance with the Contract and the Engineer's instructions. The Contractor shall also be liable for any loss or damage to the Works caused by any operations carried out by the Contractor after the date of issue of the Taking Over Certificate.

Employer's Risks

14.3

The Employer's risks of loss or damage to physical property in India and of death and personal injury occurring in India in consequence of the performance of obligations under the Contract are:

- a. war, hostilities (whether war be declared or not), invasion, act of foreign enemies,

193

GENERAL CONDITIONS OF CONTRACT

- b. rebellion, revolution, insurrection, or military or usurped power, or civil war, within India,
- c. riot, commotion or disorder by persons unless solely restricted to or caused by employees of Contractor or of Sub-contractors currently or formerly engaged in the Works,
- d. Ionising radiations, or contamination by radio-activity from any nuclear fuel, or from any nuclear waste from the combustion of nuclear fuel, radio-active toxic explosive, or other hazardous properties of any explosive nuclear assembly or nuclear component of such an assembly, except to the extent to which the Contractor may be responsible for the use of any radio-active material,
- e. pressure waves caused by aircraft or other aerial devices travelling at sonic or supersonic speeds, and
- f. use or occupation by the Employer of any part of the Works, except as may be specified in the Contract.

Consequences of Employer's Risks 14.4

If an Employer's risk results in loss or damage, the Contractor shall promptly notify the Engineer and shall rectify this loss or damage to the extent required by the Engineer.

If the Contractor suffers delay and/or incurs cost from rectifying this loss or damage, the Contractor shall give notice to the Engineer and shall be entitled to claim:

- a. extension of time for any such delay, if completion is or will be delayed, under Sub-clause 8.4, and
- b. amount of such cost, amount of such cost, which shall be included in the Contract Price.

Contractor's Risks 14.5

The Contractor's risks are all risks other than the Employer's risks given in Sub-clause 14.3.

Limitation of Liability 14.6

Except as provided otherwise in these Conditions, neither Party shall be liable to the other Party for loss of use of any Works, loss of profit, loss of any Contract or any other indirect or consequential loss or damage which may be suffered by the other Party in connection with the Contract. The total liability of the Contractor to the Employer under the Contract shall not exceed the Contract Price. Except that this Sub-clause shall not limit the liability of the Contractor:

- a. under Sub-clauses 4.18, 4.19, 5.7, 8.6, and Clauses 7.10 and 7.11
- b. under any other provisions of the Contract which expressly impose a greater liability,
- c. in cases of fraud, wilful misconduct or illegal or unlawful acts, or
- d. in cases of acts or omissions of the Contractor which are contrary to the most elementary rules of diligence which a conscientious Contractor would have followed in similar circumstances.

15 INSURANCE

Professional Indemnity Insurance 15.1

The Contractor shall effect and maintain Professional Indemnity Insurance, preferably in the name of NMRC, for the amount in Indian Rupees stipulated in Appendix to the Form of Tender in respect of any design of the Works to be carried out by, or on behalf of the Contractor. This insurance, which shall ensure the Contractor's liability by reason of

GENERAL CONDITIONS OF CONTRACT

professional negligence and errors in the design of the Works, shall be valid from the date of commencement of Works, until 5 years after the date of issue of Performance Certificate. Alternatively the Contractor shall renew the insurance before the expiry of the Yearly Insurance in such a way that the entire validity period is covered.

The Engineer will not issue Final Payment Certificate until the Contractor has produced evidence that coverage of the Professional Indemnity Insurance has been provided for the aforesaid period.

Insurance for Works and Contractor's Equipment

15.2

The Contractor shall insure the Plant, Rolling stock, Materials and Works in the joint names of the Employer, the Contractor and Sub-contractors (wherever applicable) against all loss or damage. This insurance shall cover loss or damage from any cause other than the Employer's risks listed in Sub-clause 14.3 sub paragraphs (a), (b), (d) and (e). Such insurance shall be for a limit of not less than the full replacement cost (including profit) and shall also cover the costs of demolition and removal of debris. Such insurance shall be in such a manner that the Employer and the Contractor are covered from the commencement date until the date of issue of the Taking Over Certificate for the whole of Works. However for the Works having multiple Sections / Parts in one Contract, such insurance shall be in such a manner that the Employer and the Contractor are covered from the commencement date until the date of issue of the Taking over Certificate for respective Part of Works. The Contractor shall extend such insurance to provide cover until the date of issue of the Performance Certificate, for loss or damage for which the Contractor is liable arising from a cause occurring prior to the issue of the Taking Over Certificate, and for loss or damage occasioned by the Contractor or Sub-contractors in the course of any other operations (including Clauses 7.10, 7.11 and 10).

The Contractor shall insure the Contractor's Equipment against all risks in the joint names of the Employer, the Contractor and Sub-contractors, (wherever applicable) against all loss or damage. This insurance shall cover loss or damage from any cause other than the Employer's risks listed in Sub-clause 14.3 sub- paragraphs (a), (b), (d) and (e). Such insurance shall be for a limit of not less than the full replacement value (including delivery to Site). Such insurance shall be in such a manner that each item of equipment is insured while it is being transported to the Site and throughout the period it is on or near the Site.

Insurance against injury to Persons and Damage to Property

15.3

The Contractor shall insure against liability to third Parties in the joint names of the Employer, the Contractor and Sub-contractors, (wherever applicable) for any loss, damage, death or bodily injury which may occur to any physical property (except things insured under Sub-clause 15.2) or to any person (except persons insured under Sub-clause 15.4), which may arise out of the performance of the Contract and occurring before the issue of the Performance Certificate. Such insurance shall be at least for the amount specified in the Appendix to Form of Tender.

Insurance for Workers

15.4

The Contractor shall effect and maintain insurance against losses and claims arising from the death or injury to any person employed by the Contractor or any Sub-contractor (wherever applicable) in such a manner that the Employer and the Engineer are indemnified under the policy of insurance. For Sub-contractor's employees (wherever applicable), such insurance may be effected by the Sub-contractor, but

191

GENERAL CONDITIONS OF CONTRACT

General Requirements for Insurances

15.5

the Contractor shall be responsible for compliance with this Clause.

The Contractor shall, within the respective periods stated in the Appendix to Form of Tender (calculated from the Commencement Date), submit to the Employer:

- a. evidence that the insurances described in this Clause have been effected, with an Indian Insurance Company and
- b. copies of the policies for the insurances described in Sub-clause 15.2, 15.3 and 15.4.

When each premium has been paid, the Contractor shall submit copy of receipts to the Employer. The Contractor shall also, when providing such evidence, policies and receipts to the Employer, notify the Engineer of so doing.

The Contractor shall effect all insurances for which he is responsible with insurers and in terms approved by the Employer. The Contractor would obtain waiver of right of subrogation from the insurer on the aforesaid policies of insurance. Each Policy insuring against loss or damage shall provide for payments to be made in the currencies required to rectify such loss or damage. Payments received from insurers shall be used for the rectification of such loss or damage.

The Contractor (and, if appropriate, the Employer) shall comply with the conditions stipulated in each of the Insurance Policies. The Contractor shall make no material alteration to the terms of any insurance without the prior approval of the Employer. If an insurer makes (or purports to make) any such alteration, the Contractor shall notify the Employer immediately.

If the Contractor fails to effect and keep in force any of the insurances required under the Contract, or fails to provide satisfactory evidence, policies and receipts in accordance with this Sub-clause, the Employer may, without prejudice to any other right or remedy, effect insurance for the coverage relevant to such default, and pay the premiums due. In such cases the premium paid by the Employer plus overheads (equal to 50% of the premium paid) shall be recoverable from the Contractor by the Employer, and may be deducted by the Employer from any monies due, or to become due, to the Contractor or recover the same as debt due from the Contractor. The Contractor shall not dispute the amount of premium paid by the Employer or the overhead charges thereon.

Nothing in this clause limits the obligations, liabilities or responsibilities of the Contractor or the Employer, under the other terms of the Contract or otherwise. Any amount not insured or not recovered from the insurers shall be borne by the Contractor.

The Contractor shall submit to the Engineer, the details of all claims made with the insurer and claims accepted by the insurer or any other details as required by the Engineer on monthly basis.

The Employer would be entitled to deduct from the Contract price, the premium of Insurance Policies which have not been paid or the premium of the Insurance Policies which have not been taken by the Contractor, in breach of the Contract conditions.

GENERAL CONDITIONS OF CONTRACT

16 FORCE MAJEURE

Definition of Force Majeure

16.1 In this Clause, "Force Majeure" " means an event beyond the control of the Employer and the Contractor, which makes it impossible or illegal for a Party to perform, including but not limited to:

- a. Act of God
- b. war, hostilities (whether war be declared or not), invasion, act of foreign enemies, mobilization, requisition, or embargo;
- c. rebellion, revolution, insurrection, or military or usurped power, or civil war;
- d. contamination by radio-activity from any nuclear fuel, or from any nuclear waste from the combustion of nuclear fuel, radio-active toxic explosive, or other hazardous properties of any explosive nuclear assembly or nuclear component of such an assembly;
- e. riot, commotion or disorder, unless solely restricted to employees of the Contractor or of his Sub-contractors currently or formerly engaged on the Works.

If a Party considers that it may be affected by Force Majeure, the party shall promptly notify the other Party and Engineer of such Force Majeure within 21 days of such occurrence. If neither Party issues any notice regarding the event within 21 days of its occurrence, the said event shall be deemed not to have occurred and the Contract shall continue to have no effect as such.

Effect of Force Majeure Event

16.2 Neither the Employer nor the Contractor shall be considered in default or in Contractual breach to the extent that performance of obligations is prevented by a Force Majeure event which arises after the date of Notice to Proceed. Upon the occurrence of such Force Majeure, the affected Party shall endeavour to continue to perform its obligations as far as reasonably practicable.

Contractor's Responsibility

16.3 If affected by such Force Majeure, the Contractor shall promptly notify the Engineer of any proposals for overcoming the consequences of the Force Majeure, including any reasonable alternative means for performance, but shall not carry out these proposals without the consent of the Engineer.

Employer's Responsibility

16.4 If affected by such Force Majeure, the Employer shall promptly notify the Engineer and the Contractor of any proposals for overcoming the consequences of the Force Majeure.

Payment to Contractor

16.5 If the Works shall suffer loss or damage due to such Force Majeure, the Contractor shall be entitled to have included, in an Interim Payment Certificate, the Cost of Work executed in accordance with the Contract.

Resumption of Work

16.6 The obligations under the Contract shall be resumed as soon as practicable after the event has come to an end or ceased to exist.

In case of doubt or dispute, whether a particular occurrence should be considered an "event" as defined under this Clause, the decision of the Engineer shall be final and binding.

Works that have already been measured shall be paid for by the Employer even if the same is subsequently destroyed or damaged as a result of the event. The cost of rebuilding or replacing any Work that has been measured shall be borne by the Employer.

180

GENERAL CONDITIONS OF CONTRACT

Optional Termination, Payment and Release

16.7

Irrespective of any extension of time, if a Force Majeure occurs and it's effect continues for a period of 6 months, after notice has been given under Sub- clause 16.1, either Party may give to the other party a notice of termination of the Contract which shall take effect in 28 days after the notice is given. Unless at the end of 28 days period the effect of the Force Majeure has ceased, the Contract shall terminate upon that date. Otherwise, the Contract shall remain in effect.

The Contractor shall be paid fully for the Work done under the Contract, but not for any defective Work or Work done which has been destroyed or damaged before its measurement. The Employer shall have the option to take over any Plant, Rolling Stock and Materials lying at site, at rates provided for in the Contract, failing that, as per rates, which are determined to be fair and reasonable by the Engineer.

Release from Performance Under the Law

16.8

If under the law of the Contract, the Employer and the Contractor are released from further performance, the sum payable by the Employer to the Contractor shall be the same as would have been payable under Sub-clause 16.7, if the Contract had been terminated under that Sub-clause.

17

CLAIMS, DISPUTES, CONCILIATION AND ARBITRATION

Procedure for Claims

17.1

Procedure for Claims

If the Contractor intends to claim any additional payment under any Clause of these Conditions or otherwise, the Contractor shall give notice to the Engineer as soon as possible and in any event within 28 days of the start of the event giving rise to the claim. The Contractor shall also submit any other notices which are required by the Contract, and supporting particulars for the claim, all as relevant to such event or circumstance.

The Contractor shall keep such contemporary records as may be necessary to substantiate any claim, either on the Site or at any other location acceptable to the Engineer. Without admitting the Employer's liability, the Engineer shall on receipt of such notice, inspect such records, monitor the record-keeping and/or may instruct the Contractor to keep further contemporary records. The Contractor shall permit the Engineer to inspect all such records, and shall (if instructed) submit copies to the Engineer.

Within 28 days of such notice, or such other time as may be agreed by the Engineer, the Contractor shall send to the Engineer a fully detailed claim which includes full supporting particulars of the basis of the claim and additional payment claimed. If the event or circumstance giving rise to the claim has a continuing effect:

- a. this fully detailed claim shall be considered as Interim;
- b. the Contractor shall send further interim claims at monthly intervals, giving the accumulated amount claimed, and such further particulars as the Engineer may reasonably require; and
- c. the Contractor shall send a final claim within 28 days after the end of the effects resulting from the event or circumstance, or within such other period as may be proposed by the Contractor and approved by the Engineer.

If the Contractor fails to comply with this Sub-clause, he shall not be entitled to claim any additional payment.

Payment for

17.2

The Contractor shall be entitled to have included in any Interim Payment

GENERAL CONDITIONS OF CONTRACT

		entitled to claim any additional payment.
Payment for Claims	17.2	The Contractor shall be entitled to have included in any Interim Payment Certificate such amount for any claim as the Engineer considers due, after taking approval from the Employer. If the particulars supplied are insufficient to substantiate the whole of the claim, the Contractor shall be entitled to payment for such part of the claim as has been substantiated.
No legal action Till Dispute Settlement Procedure is Exhausted	17.3	Any and all Disputes shall be settled in accordance with the provisions of Clause 17. No action at law concerning or arising out of any Dispute shall be commenced unless and until all applicable Dispute resolution procedures set out in Clause 17 shall have been finally exhausted in relation to that Dispute or any Dispute out of which that Dispute shall have arisen with which it may be or may have been connected.
Notice of Dispute	17.4	For the purpose of Sub-clause 17.5, a Dispute shall be deemed to arise when one Party serves on the other Party a notice in writing (hereinafter called a "Notice of Dispute") stating the nature of the Dispute provided that no such notice shall be served later than 28 days after the date of issue of Performance Certificate by the Engineer.
Two Stages for Dispute Resolution	17.5	Disputes shall be settled through two stages: <ul style="list-style-type: none"> a. Conciliation procedures as established by "The Arbitration and Conciliation Act-1996" & amended by the Arbitration & Conciliation (Amendment) Act, 2019 and any statutory modification or re-enactment thereof and in accordance with this Clause. In the event, this procedure fails to resolve the Dispute then; b. Arbitration procedures undertaken as provided by "The Arbitration and Conciliation Act -1996" & amended by the Arbitration & Conciliation (Amendment) Act, 2019 and any statutory modification or re-enactment thereof and in accordance with this Clause.
Conciliation	17.6	Within 60 days of receipt of Notice of Dispute, either party shall refer the matter in dispute to Conciliation. Conciliation proceedings shall be initiated within 30 days of one Party inviting the other in writing to Conciliation. Conciliation shall commence when the other Party accepts in writing this invitation. If the invitation is not accepted then Conciliation shall not take place. If the Party initiating Conciliation does not receive a reply within 30 days from the date on which he sends the invitation, he may elect to treat this as a rejection of the invitation to conciliate and inform the other Party accordingly. The Conciliation shall be undertaken by one Conciliator selected from a panel of Conciliators maintained by the Employer. The Conciliator shall assist the Parties to reach an amicable settlement in an independent and impartial manner.
Conciliation Procedure	17.7	The Employer shall maintain a panel of Conciliators, who shall be from serving or retired Engineers of Government Departments, or of Public Sector Undertakings. Out of this panel, a list of three Conciliators shall be sent to the Contractor who shall choose one of them to act as Conciliator and conduct Conciliation proceedings in accordance with "The Arbitration and Conciliation Act, 1996" of India & amended by the Arbitration & Conciliation (Amendment) Act, 2019 and any statutory modification or re-enactment thereof. There will be no objection if Conciliator so nominated is a serving employee of NMRC who would be Deputy HOD level officer and above. The Employer and the Contractor shall in good faith co-operate with the

187

GENERAL CONDITIONS OF CONTRACT

Conciliator and, in particular, shall endeavour to comply with requests by the Conciliator to submit written materials, provide evidence and attend meetings.

Each Party may, on his own initiative or at the invitation of the Conciliator, submit to the Conciliator suggestions for the settlement of the dispute.

When it appears to the Conciliator that there exist elements of a settlement which may be acceptable to the Parties, he shall formulate the terms of a possible settlement and submit them to the Parties for their observations. After receiving the observations of the Parties, the Conciliator may reformulate the terms of a possible settlement in the light of such observations.

If the Parties reach agreement on a settlement of the dispute, they may draw up and sign a written settlement agreement. If requested by the Parties, the Conciliator may draw up, or assist the Parties in drawing up, the settlement agreement. When the Parties sign the Settlement Agreement, it shall be final and binding on the Parties and persons claiming under them respectively.

The Conciliator shall authenticate the Settlement Agreement and furnish a copy thereof to each of the Parties. As far as possible, the Conciliation proceedings should be completed within 60 days of the receipt of notice by the Conciliator.

The Parties shall not initiate, during the Conciliation proceedings, any arbitral or judicial proceedings in respect of a dispute that is the subject matter of the Conciliation proceedings.

Termination of Conciliation Proceedings

17.8

The Conciliation proceedings shall be terminated:

- a. by the signing of the Settlement Agreement by the Parties on the date of agreement; or
- b. by written declaration of the Conciliator, after consultation with the Parties, to the effect further efforts at Conciliation are no longer justified, on the date of declaration; or
- c. by a written declaration of the Parties to the Conciliator to the effect that the Conciliation proceedings are terminated, on the date of declaration; or
- d. by a written declaration of a Party to the other Party and the Conciliator, if appointed, to the effect that the Conciliation proceedings are terminated, on the date of declaration.
- e. Upon termination of the Conciliation proceedings, the Conciliator shall fix the costs of the Conciliation and give written notice thereof to the Parties. The costs shall be borne equally by the Parties unless Settlement Agreement provides for a different apportionment. All other expenses incurred by a Party shall be borne by that Party.

Arbitration

17.9

If the efforts to resolve all or any of the disputes through Conciliation fails, then such disputes or differences, whatsoever arising between the Parties, arising out of touching or relating to construction/ manufacture, measuring operation or effect of the Contract or the breach thereof shall be referred to Arbitration in accordance with the following provisions:

- a. Only such dispute(s) or difference(s) in respect of which notice has been made under Clause 17.1 but could not be settled through Conciliation, together with counter claims or set off, given by the Employer, shall be referred to Arbitration. Other matters shall not be included in the reference.
- b. The Arbitration proceedings shall be assumed to have

GENERAL CONDITIONS OF CONTRACT

NOIDA(MD/NMRC).

c. The disputes so referred to Arbitration shall be settled in accordance with the Indian Arbitration & Conciliation Act, 1996 & amended by the Arbitration & Conciliation (Amendment) Act, 2019 and any statutory modification or re-enactment thereof.

Further, it is agreed between the Parties as under:

17.9.1 Number of Arbitrators: The Arbitral Tribunal shall consist of:

- i. Sole Arbitrator in cases where the total value of all claims in question added together does not exceed `2.00 crores;
- ii. 3 (Three) Arbitrators in all other cases.

17.9.2 Procedure for Appointment of Arbitrators: The Arbitrators shall be appointed as per following procedure:

i. In case of Sole Arbitrator: Within 60 days from the day when a written and valid demand for Arbitration is received by MD/NMRC, the Employer will forward a panel of 03 names to the Contractor. The Contractor shall have to choose one Arbitrator from the panel of three, to be appointed as Sole Arbitrator within 30 days of dispatch of the request by the Employer. In case the Contractor fails to choose one Arbitrator within 30 days of dispatch of the request of the Employer then MD/NMRC shall appoint any one Arbitrator from the panel of 03 Arbitrators, as sole Arbitrator.

ii. In case of 3 Arbitrators:

a. Within 60 days from the day when a written and valid demand for Arbitration is received by MD/NMRC, the Employer will forward a panel of 5 names to the Contractor. The Contractor will then give his consent for any one name out of the panel to be appointed as one of the Arbitrators within 30 days of dispatch of the request by the Employer.

b. Employer will decide the second Arbitrator. MD/NMRC shall appoint the two Arbitrators, including the name of one Arbitrator for whom consent was given by the Contractor, within 30 days from the receipt of the consent for one name of the Arbitrator from the Contractor. In case the Contractor fails to give his consent within 30 days of dispatch of the request of the Employer then MD/NMRC shall nominate both the Arbitrators from the panel.

c. The third Arbitrator shall be chosen by the two Arbitrators so appointed by the Parties out of the panel of 05 Arbitrators provided to Contractor or from the larger panel of Arbitrators to be provided to them by Employer at the request of two appointed Arbitrators (if so desired by them) and who shall act as Presiding Arbitrator. In case of failure of the two appointed Arbitrators to reach upon consensus within a period of 30 days from their appointment date, then, upon the request of either or both Parties, the Presiding Arbitrator shall be appointed by the Managing Director / NMRC, Noida.

d. If one or more of the Arbitrators appointed as above refuses to act as Arbitrator, withdraws from his office as Arbitrator, or vacates his/their office/offices or is/are unable or unwilling to perform his functions as Arbitrator for any reason whatsoever or dies or in the opinion of the MD/NMRC fails to act without undue delay, the MD/NMRC shall appoint new Arbitrator /Arbitrators to act in his/their place except in case of new Presiding Arbitrator who shall be chosen following the same procedure as mentioned in para (ii)(c) above. Such re-constituted Tribunal may, at its

GENERAL CONDITIONS OF CONTRACT

discretion, proceed with the reference from the stage at which it was left by the previous Arbitrator(s).

e. The Employer at the time of offering the panel of Arbitrator(s) to be appointed as Arbitrator shall also supply the information with regard to the qualifications of the said Arbitrators nominated in the panel along with their professional experience, phone nos. and addresses to the Contractor.

- 17.9.3 Qualification and Experience of Arbitrators (to be appointed as per Sub-clause 17.9.2 above): The Arbitrators to be appointed shall have minimum qualification and experience as under:
Arbitrator shall be;
a Working / Retired Officer (not below E-8 grade in a PSU with which NMRC has no business relationship) of any discipline of Engineering or Accounts / Finance department, having experience in Contract Management of Construction Contracts; or a Retired Officer (retired not below the SAG level in Railways) of any Engineering Services of Indian Railways or Indian Railway Accounts Service, having experience in Contract Management of Construction Contracts; or a Retired Officer who should have retired more than 3 years previously from the date of appointment as Arbitrator (retired not below E-8 grade in NMRC or a PSU with which NMRC has a business relationship) of any Engineering discipline or Accounts / Finance department, having experience in Contract Management of Construction Contracts or retired judge of any High Court or Supreme Court of India or reputed Chartered Accountant & should be member of ICAI, New Delhi. No person other than the persons appointed as per above procedure and having above qualification and experience shall act as Arbitrator.
- 17.9.4 No new claim shall be added during proceedings by either Party. However, a Party may amend or supplement the original claim or defence thereof during the course of Arbitration proceedings subject to acceptance by Tribunal including having due regard to the delay in making it.
- 17.9.5 Neither Party shall be limited in the proceedings before such Arbitrator(s) to the evidence nor did arguments put before the Engineer for the purpose of obtaining his decision. No decision given by the Engineer in accordance with the foregoing provisions shall disqualify him from being called as a witness and giving evidence before the Arbitrator(s) on any matter, whatsoever, relevant to dispute or difference referred to Arbitrator/s. Neither Party shall be limited in the proceedings before such Arbitrators to the evidence nor did arguments previously put before during settlement through Conciliation proceedings.
- 17.9.6 It is agreed by both the Parties that in the cases where Arbitral Tribunal is consist of Sole Arbitrator, their disputes shall be resolved by fast track procedure specified in sub-section (3) of 29B of the Arbitration and Conciliation (Amendment) Act , 2019 or as amended up to date.
- 17.9.7 If the Contractor(s) does/do not prefer his/their specific and final claims in writing, within a period of 90 days of receiving the intimation from the Employer/Engineer that the final bill is ready for signature of the Contractor(s), he/they will be deemed to have waived his/their claim(s) and the Employer shall be discharged and released of all liabilities under the Contract in respect of these claims.
- 17.9.8 Arbitration proceedings shall be held at District GautamBudhNagar, Uttar Pradesh, India and the language of the Arbitration proceedings and that

GENERAL CONDITIONS OF CONTRACT

of all documents and communications between the Parties shall be in English.

17.9.9 The Arbitral Tribunal should record day to day proceedings. The proceedings shall normally be conducted on the basis of documents and written statements. All Arbitration awards shall be in writing and shall state item wise, the sum and detailed reasons upon which it is based. A model Time Schedule for conduct of Arbitration proceedings in a period of 180 days / 365 days will be made available to Arbitral Tribunal for their guidance. Both the Parties should endeavor to adhere to time schedule for early finalization of Award.

17.9.10 The award of the Sole Arbitrator or the award by majority of three Arbitrators as the case may be shall be binding on all Parties. Any ruling on award shall be made by a majority of members of Tribunal. In the absence of such a majority, the views of the Presiding Arbitrator shall prevail.

17.9.11 A Party may apply for correction of any computational errors, any typographical or clerical errors or any other error of similar nature occurring in the award of a Tribunal and interpretation of specific point of award to Tribunal within 60 days/30 days of the receipt of award.

17.9.12 A Party may apply to Tribunal within 60 days/30 days of receipt of award to make an additional award as to claims presented in the Arbitral proceedings but omitted from the Arbitral award.

Interest on Arbitration Award

17.10 Where the Arbitral award is for the payment of money, no interest shall be payable on whole or any part of the money for any period, till the date on which the award is made.

Cost of Conciliation/ Arbitration

17.11 The fees and other charges of the Conciliator / Arbitrators shall be as per the scales fixed by the Employer from time to time irrespective of the fact whether the Arbitrator(s) is / are appointed by the Employer or by the Court of law unless specifically directed by Hon'ble Court otherwise on the matter, and shall be shared equally by the Employer and the Contractor. However, the expenses incurred by each Party in connection with the preparation, presentation will be borne by itself.

Jurisdiction of Courts

17.12 Where recourse to a Court is to be made in respect of any matter, dispute, issue arising out of or under the Contract or connected with the Contract the Appropriate court at District Gautam Budh Nagar, Uttar Pradesh shall have the exclusive jurisdiction to try all disputes issues, dispute arising out of or under the Contract or connected with the Contract between the Parties.

Suspension of Work on Account of Arbitration

17.13 The reference to Conciliation / Arbitration shall proceed notwithstanding that the Works shall not then be or be alleged to be complete, provided always that the obligations of the Employer, Engineer and the Contractor shall not be altered by reasons of Arbitration being conducted during the progress of the Works. Neither Party shall be entitled to suspend the Work or part of the Work to which the dispute relates on account of Arbitration and payments to the Contractor shall continue to be made in terms of the Contract.

18 SERVICE OF NOTICES

Notice to Contractor

18.1 a. All notices to the Contractor shall be served by post or telex or telefax or e-mail or by hand to the Contractor or his authorized Representatives. In case of notices delivered by post, they will be deemed to have been delivered after 7 days of dispatch.

b. The Contractor shall, on award of the Contract, furnish to the

183

GENERAL CONDITIONS OF CONTRACT

Engineer, the name, designation, address and telephone, telex and telefax numbers and e-mail address of his representative referred to in Clause 4.3.

Notice to Employer and Engineer

18.2

All notices to the Employer or Engineer shall be served by post or telex or telefax, or by e-mail or by delivering by hand to the address nominated for the purpose.

Change of Address

18.3

Parties to the Contract may change the nominated their address by Employer with a notice to all concerned.

[Handwritten signatures in blue ink]