

Design, engineering, manufacture, supply, Installation, testing and commissioning of, 630KVA, 33KV/415V Compact Substation, Cabling and other accessories to be installed, its Integration with Existing NMRC SCADA at NMRC stations KP-II, Pari Chowk.

NOIDA METRO RAIL CORPORATION (NMRC) LIMITED

REQUEST FOR PROPOSAL (RFP)

E-tender No. NMRC/PD/CSS/309R/321/2024

Design, engineering, manufacture, supply, Installation, testing and commissioning of, 630KVA, 33KV/415V Compact Substation, Cabling and other accessories to be installed, its Integration with Existing NMRC SCADA at NMRC stations KP-II, Pari Chowk.

Jun 2024

Issued by:

**Noida Metro Rail Corporation (NMRC) Limited
Block-III, 3rd Floor,
Ganga Shopping Complex, Sector-29, Noida -201301,
District Gautam Budh Nagar, Uttar Pradesh, India**

Design, engineering, manufacture, supply, Installation, testing and commissioning of, 630KVA, 33KV/415V Compact Substation, Cabling and other accessories to be installed, its Integration with Existing NMRC SCADA at NMRC stations KP-II, Pari Chowk.

Disclaimer

This Request for Proposal (RFP) Document (or “E-Tender” or “E-Bid”) for **“Design, engineering, manufacture, supply, Installation, testing and commissioning of, 630KVA, 33KV/415V Compact Substation, Cabling and other accessories to be installed, its Integration with Existing NMRC SCADA at NMRC stations KP-II, Pari Chowk.”** contains brief information about the scope of work and selection process for the Bidder (“the Contractor” or “the Bidder”). The purpose of the Document is to provide the Bidders with information to assist the formulation of their Bidding Documents.

While all efforts have been made to ensure the accuracy of information contained in this RFP Document, this Document does not purport to contain all the information required by the Bidders. The Bidders should conduct their own independent assessment, investigations and analysis and should check the reliability, accuracy and completeness of the information at their end and obtain independent advice from relevant sources as required before submission of their Bid/s. Noida Metro Rail Corporation Ltd. (“NMRC” or “the Corporation” or “the Employer”) or any of its employees or advisors shall incur no liability under any law, statute, rules or regulations as to the accuracy or completeness of the RFP Document.

NMRC reserves the right to change any or all conditions/information set in this RFP Document by way of revision, deletion, updating or annulment through issuance of appropriate addendum as NMRC may deem fit without assigning any reason thereof.

NMRC reserves the right to accept or reject any or all Bids without giving any reasons thereof. NMRC will not entertain or be liable for any claim for costs and expenses in relation to the preparation of the Bid/s to be submitted in terms of this RFP Document.

Design, engineering, manufacture, supply, Installation, testing and commissioning of, 630KVA, 33KV/415V Compact Substation, Cabling and other accessories to be installed, its Integration with Existing NMRC SCADA at NMRC stations KP-II, Pari Chowk.

Glossary

- a) **“Addendum / Amendment”** means any written amendment / addendum /corrigendum to this RFP, from time to time issued by NMRC to the prospective bidders
- b) **“Agreement”** means the Contract Agreement to be executed between NMRC and the Selected Bidder
- c) **“Applicable Laws”** means all the laws including local, state, national or other laws, brought into force and effect by Govt. of India, State Governments, local bodies, statutory agencies and any other, and rules / regulations / notifications issued by them from time to time. It also includes judgments, decrees, injunctions, writs and orders of any court or judicial authority as may be in force and effected from time to time
- d) **“Bidder”** or **“Bidder”** means any entity which is a sole proprietorship firm, a partnership firm or a company, in title and assigns which is submitting its bid pursuant to RFP Documents
- e) **“Bid Due Date”** means Bid Submission end date and time given in the E-tender
- f) **“Earnest Money Deposit (EMD)”** means the refundable amount to be submitted by the Bidder along with RFP documents to NMRC
- g) **“NMRC”** means Noida Metro Rail Corporation Limited (or “Corporation” or “Employer”)
- h) **“Party”** means Contractor or Corporation (together they are called **“Parties”**)
- i) **“Performance Bank Guarantee/ Security Deposit”** means interest free amount to be deposited by the Contractor with NMRC as per terms and conditions of Contract Agreement as a security against the performance of the Contract agreement
- j) **“Permits”** shall mean and include all applicable statutory, environmental or regulatory Contracts, authorization, permits, consents, approvals, registrations and franchises from concerned authorities
- k) **“Re. or Rs. or INR”** means Indian Rupee
- l) **“Revenue Operations Date (ROD)”** means the date of operation of Metro
- m) **“Selected Bidder”** means the bidder who has been selected by NMRC, pursuant to the bidding process for award of Contract

The words and expressions beginning with capital letters and defined in this document shall, unless repugnant to the context, have the meaning ascribed thereto hereinabove.

Design, engineering, manufacture, supply, Installation, testing and commissioning of, 630KVA, 33KV/415V Compact Substation, Cabling and other accessories to be installed, its Integration with Existing NMRC SCADA at NMRC stations KP-II, Pari Chowk.

Data Sheet

1	Name of the Bid	Design, engineering, manufacture, supply, Installation, testing and commissioning of, 630KVA, 33KV/415V Compact Substation, Cabling and other accessories to be installed, its Integration with Existing NMRC SCADA at NMRC stations KP-II, Pari Chowk.
2	Approximate Cost of Work	INR 7,10,23,213.85 (including GST)
3	Time-period of contract	Eight Months
4	Method of selection	Cost Based Selection (Lowest -L1)
5	Bid Processing Fee	INR 23,600 (including GST) (Rupees Twenty Three Thousand Six Hundred only) through RTGS/NEFT only payable in favour of Noida Metro Rail Corporation Limited
6	Ernest Money Deposit (EMD)	INR 7,10,232 /- (Rupees Seven Lakh Ten Thousand Two Hundred Thirty Two only)
7	Financial Bid to be submitted together with Technical Bid	Yes
8	Name of the Corporation's official for addressing queries and clarifications	ED. Noida Metro Rail Corporation Limited, Block-III, 3rd Floor, Ganga Shopping Complex, Sector-29, Noida 201301 Email: avikdmrc@gmail.com , nmrcrsandel@gmail.com Website: www.nmrcnoida.com , http://etender.up.nic.in
9	Bid Validity Period	180 days
10	Bid Language	English
11	Bid Currency	INR
12	JV	Not allowed
12	Schedule of Bidding Process	
	Head	Key Dates
	Uploading of Bid	05.06.2024
	Pre-bid Meeting	10.06.2024, 12:00 hrs (IST)
	Last date of submission of Queries , If any	14.06.2024
	Last date of issuing amendment, if any	01.07.2024
	Last Date of Bid Submission	03.07.2024, 11:00 hrs (IST)
	Date of Technical Bid Opening	05.07.2024, 16:00 hrs (IST)
13	Consortium to be allowed	Not allowed
14	Account details	For Bid Processing Fee & EMD ICICI Bank Ltd. (04077) – Sector 18, Noida Branch K-1 Senior Mall, Sec. 18, Noida, Uttar Pradesh -201301 IFSC Code: ICIC0000031 A/c No.: 003101230061 Noida Metro Rail Corporation Ltd.

Design, engineering, manufacture, supply, Installation, testing and commissioning of, 630KVA, 33KV/415V Compact Substation, Cabling and other accessories to be installed, its Integration with Existing NMRC SCADA at NMRC stations KP-II, Pari Chowk.

Content

Disclaimer..... 2

Glossary 3

Data Sheet 4

1. Section 1: General Information 7

1.1 Background..... 7

1.2 About Metro Locations..... 7

1.3 Communication 7

2. Section 2: Terms of Reference 8

2.1 Scope of Work..... 8

3. Section 3: Instructions to Bidders..... 9

3.1 General instructions 9

3.2 Preparation and submission of Bids..... 11

3.3 Earnest Money Deposit 16

3.4 Opening and Evaluation of Bids..... 16

3.5 Award of Contract 18

4. Section 4: Qualification, Evaluation and Selection Process 20

4.1 Eligibility Criteria..... 20

4.2 Bid Capacity Criteria 21

4.3 Personnel..... 22

4.4 Compliance with Technical Specifications..... 23

4.5 Information of the Technical and Financial Proposal 23

4.6 Selection of Bidder 23

4.7 Notice of Award and Execution of Contract Agreement..... 24

4.8 Performance Bank Guarantee / Security Deposit 24

4.9 Contract during Proposal Evaluation..... 25

4.10 Other Instruction..... 26

4.11 Project Financial Terms..... 26

4.12 Contractor’s Labour Camp 26

5. Section 5: Special Conditions of Contract (SCC) 29

6. Section 6: Codes & standards 36

6.1 Section 6: Package substation part details..... 37

6.1.1 Design Criteria of CSS 39

6.1.2 Service Conditions 39

6.1.3 Design requirement of 33kV CSS & 33kV RMU 39

6.1.4 Outdoor enclosure..... 39

6.1.5 Internal Fault..... 40

6.1.6 Covers & Doors..... 40

6.1.7 Earthing 40

6.1.8 Labels 40

6.1.9 Cleaning & Painting..... 40

6.1.10 General Finish..... 40

6.1.11 Ratings..... 41

6.1.12 Breaking & Making Capacity:..... 41

6.1.13 Busbars..... 41

6.1.14 Earth Switch..... 41

6.1.15 The Mechanism..... 41

6.1.16 Front covers 41

6.1.17 Position Indicator..... 41

6.1.18 Voltage indicator:..... 41

6.1.19 Cable Compartment 41

6.1.20 Power Connection 41

6.1.21 Fault passage Indicator: 41

6.1.22 Switchgear: 42

Design, engineering, manufacture, supply, Installation, testing and commissioning of, 630KVA, 33KV/415V Compact Substation, Cabling and other accessories to be installed, its Integration with Existing NMRC SCADA at NMRC stations KP-II, Pari Chowk.

6.1.23	Vacuum Circuit Breaker.....	42
6.1.24	Protection Relay.....	42
6.2	Performances required.....	42
6.3	Protection descriptions.....	43
6.4	Staging of protections.....	44
6.5	CSS equipment protection.....	45
6.6	Low voltage switchgear.....	45
6.7	Control switch for air circuit breakers.....	46
6.8	ACB controlled & monitored and interlocks.....	47
7.	Cables Standards, Laying and Other guidelines.....	48
8.	Transformer and specifications.....	55
8.1	Fire protection scheme & integration with SCADA/FACP.....	57
8.2	Distribution transformer data sheet.....	57
9.	SCADA and signal list.....	61
9.1	Signal List.....	62
10.	Plan submission and Schedule of work.....	64
10.1	Scope of Work for DLP cum CAMC.....	64
10.2	Duties of Engineer.....	65
10.3	Duties of Skilled Technician.....	65
11.	Statutory approval, inspection & tests.....	66
11.1	Inspection & tests certificates.....	66
11.2	Test certificates.....	67
12.	Drawings, manuals and General requirements.....	67
13.	Tentative Make of components.....	69
14.	Tentative Drawings of the CSS work, Existing 33 KV line SLD, GTP of Cable.....	71
14.1	Tentative Drawings of the CSS work.....	71
14.2	Existing 33 KV line SLD.....	72
14.3	GTP of 33 KV Cable.....	73
15.	Section 7: Draft Contract Agreement.....	76
16.	Section 8: Appendix and Forms of Tender.....	79
16.1	Appendix 1: Metro Alignment.....	79
16.2	Appendix 2: Quality Assurance.....	80
16.3	Quality Assurance Management Plan.....	80
16.4	Plan Implementation and Verification.....	81
17.	Form 1: Letter of Proposal Submission.....	82
17.1	Form 2: Firm Details.....	83
17.2	Form 3: Capability Statement.....	84
17.3	Form 4: Work Experience.....	86
17.4	Form 5: Financial Capability Details.....	87
17.5	Form 6: Memorandum.....	89
17.6	Form 7: Undertaking.....	90
17.7	Form 8: Power of Attorney.....	91
17.8	Form 9: Saleable Form for Tender Document.....	93
17.9	Form 10: Declaration of Refund of Earnest Money.....	94
17.10	Form 11: Undertaking pertaining to Personnel.....	95
17.11	Form 12: Resources proposed for the O&M - Plant & Equipment.....	96
17.12	Form 13: Bid Capacity Information.....	97
17.13	Form 14: Proposed Personnel.....	99
17.14	Form 15: Obligation/ Compliance to be ensured by Contractor.....	100
17.15	Form 16: Performa for Clarifications / Amendments on the RFP.....	101
17.16	Form 17: Bid Offer/ BOQ (Format).....	102
17.17	Form 18: Bid Details.....	109

Design, engineering, manufacture, supply, Installation, testing and commissioning of, 630KVA, 33KV/415V Compact Substation, Cabling and other accessories to be installed, its Integration with Existing NMRC SCADA at NMRC stations KP-II, Pari Chowk.

1. Section 1: General Information

1.1 Background

- a. Noida and Greater Noida are being developed as the satellite towns to New Delhi and an increasing number of people from Delhi and other areas are shifting to these towns in search of fresh air, greenery and better infrastructure. There is a need of providing an efficient, reliable and comfortable transportation system for the population intending to settle in these towns and to the public coming to these areas for education, service and business.
- b. Noida Metro Rail Corporation is a Special Purpose Vehicle (SPV) formed by Noida and Greater Noida Authorities for planning and executing urban transport projects in Noida and Greater Noida regions. The Corporation desires to provide a world-class Public Transportation System with state-of-the-art technology. As such, the overarching criterion for setting up of the Corporation is to help create an efficient, safe, reliable, economical and affordable public transport system.
- c. NMRC invites E-Bids **Design, engineering, manufacture, supply, Installation, testing and commissioning of, 630KVA, 33KV/415V Compact Substation, Cabling and other accessories to be installed, its Integration with Existing NMRC SCADA at NMRC station KP-II, Pari Chowk.**
- d. In this regard, the Corporation now invites the interested Bidder/s to submit their proposals as per provisions of this RFP Document.
- e. NMRC will shortlist the Bidders based on evaluation criteria mentioned in this RFP Document. Based on the minimum evaluation criteria, qualified Bidders will be shortlisted, and financial proposal of only qualified Bidders will be opened.

1.2 About Metro Locations

The metro corridor is 29.7 km long and is known as Noida Greater Noida Metro Rail Corridor. It comprises 21 metro stations starting from Sector 51 in Noida and ends up at Depot Station in Greater Noida. The map is in Appendix 1: Metro Alignment.

1.3 Communication

All communications should be addressed to -

ED.

**Noida Metro Rail Corporation (NMRC) Limited
Block-III, 3rd Floor, Ganga Shopping Complex, Sector-29,
Noida -201301
District Gautam Budh Nagar, Uttar Pradesh
Email: nmrcnoida@CGMail.com, nmrcrsandel@gmail.com**

Design, engineering, manufacture, supply, Installation, testing and commissioning of, 630KVA, 33KV/415V Compact Substation, Cabling and other accessories to be installed, its Integration with Existing NMRC SCADA at NMRC stations KP-II, Pari Chowk.

2. Section 2: Terms of Reference

2.1 Scope of Work

- a. The work covered in the tender is as per BOQ placed in section of this RFP.
- b. The technical specifications are set forth in technical specifications- Section 6 of this RFP.
- c. The bidder should inspect the work site after receiving NOA and obtain for himself at his own responsibility all the information which may be necessary for the purpose of the successful execution of the contract.
- d. The bidder shall also make himself conversant with all the local conditions, means of access to the site of work, nature, extent of transport facilities and character of the work and supply of materials, conditions affecting labour and other matters that may affect his tender.
- e. All the work in the BOQ must be done as per instructions of Engineer In charge and also take approval of Make of BOQ items before any purchase.
- f. The commissioning work of CSS shall be carried out with existing NMRC 33 KV Ring Network.
- g. The bidder has to obtain necessary scheme approval after the receipt of NOA.
- h. The bidder shall complete necessary Electrical/Civil works associated with the installation, testing and commissioning of Compact substation and other associated work like cable and laying on cable tray or underground etc. as per BOQ as required, foundation as required and mending good the damages and giving final finishing and to match with the existing surface.
- i. The platform for installing the CSS has to be made by the bidder.
- j. The final approval shall be obtained from E/I. NOC must be submitted to this office from the office of the CHIEF ELECTRICAL INSPECTOR TO THE GOVERNMENT OF INDIA for the metro work and NO extra payment will be released from NMRC for this and compliance pertains to safety observation from electrical inspectorate/electrical safety department.**
- k. All statutory approval including, electrical inspectorate and regularization from concerned authorities should be carried out by the bidder and all applicable charges to be borne by the successful bidder. If the schematic drawings are requested by the electrical inspectorate or any statutory authority the bidder has to prepare the drawing and to take the approval from EI. The soft and hard copy of the said drawing is to be handed over to the tender inviting authority before releasing the final payment.
- l. The equipment including the accessories shall be covered under comprehensive warranty period/defect liability period. During this period the successful bidder shall replace all defective parts and attend to all repairs / breakdowns. The cost of spare parts for all replacements has to be borne by the successful bidder during the period of comprehensive warranty/DLP.

3. Section 3: Instructions to Bidders

3.1 General instructions

- a. A Bidder shall submit only one bid in the same tendering process, either individually as a Bidder. A Bidder who submits or participates in more than one bid will cause all the proposals in which the Bidder has participated to be disqualified. No Bidder can be a sub-contractor while submitting a bid individually or as a partner of a Consortium in the same bidding process. A Bidder, if acting in the capacity of subcontractor in any bid, may participate in more than one bid, but only in that capacity.
- b. The Bidder shall initiate, and actively pursue and involve itself in all investigations and enquiries, Corporation feedbacks, information, convening of and attendance at meetings, and in any other activities as are or may be necessary for producing high quality work as per the requirements.
- c. The Bidder shall carry out the services in compliance with the provisions of this Agreement. All changes necessary to ensure that the Bidder's documents conform to the intent and purpose set out in the Agreement, shall be made at the Bidder's own expense. The Bidder represents that it is a professional and experienced company, and hereby agrees to bear full responsibility for the correctness and technical merit of the services performed.
- d. Bidders shall be evaluated based on the Evaluation Criteria specified in this document. Bidders shall be deemed to have understood and agreed that no explanation or justification for any aspect of the Selection Process will be given and that NMRC's decisions are without any right of appeal whatsoever.
- e. Any entity which has been barred by the Central/State Government in India or by any entity controlled by them, from participating in any project, and the bar subsists as on the date of Bid, would not be eligible to submit an e - Bid.
- f. Bidders are encouraged to inform themselves fully about the assignment and the local conditions before submitting the e-Bid by paying a visit to the Corporation and/or by sending written queries to NMRC before the last date for receiving queries/clarifications.
- g. NMRC shall not be liable for any omission, mistake or error on the part of the Bidder in respect of any of the above or because of any matter or thing arising out of or concerning or relating to e-Bid or the Selection Process, including any error or mistake therein or in any information or data given by NMRC.
- h. The currency for the Proposal shall be the Indian Rupee (INR).
- i. Bidders shall not have a conflict of interest. All Bidders found to have a conflict of interest shall be disqualified. Bidders shall be considered to have a conflict of interest with one or more parties in this bidding process, if:
 - i. A Bidder has been engaged by the Employer to provide consulting services for the preparation related to procurement or implementation of the project;
 - ii. A Bidder is any associates/affiliates (inclusive of parent firms) mentioned in subparagraph above; or
 - iii. A Bidder lends, or temporarily seconds its personnel to firms or organizations which are engaged in consulting services for the preparation related to procurement for an implementation of the project, if the personnel would be involved in any capacity on the same project.

Design, engineering, manufacture, supply, Installation, testing and commissioning of, 630KVA, 33KV/415V Compact Substation, Cabling and other accessories to be installed, its Integration with Existing NMRC SCADA at NMRC station KP-II, Pari Chowk.

3.1.1 Cost of Bid Document / e-Tender processing Fee

- a. The Bidder shall bear all costs associated with the preparation and submission of its e-Bid and Noida Metro Rail Corporation Ltd. ("NMRC" or "the Corporation"), will in no case be responsible or liable for these costs, regardless of the conduct or outcome of the e-Bid process.
- a. This tender document is available on the web site <http://etender.up.nic.in> or on NMRC website (www.nmrcnoida.com) to enable the Bidders to view, download the e-Bid document and submit e-Bids online up to the last date and time mentioned in e-Tender notice/e-tender document against this e-Tender. The Bidders shall have to pay cost of bid document/e-Tender processing fee of as mentioned in **Data Sheet** through RTGS/NEFT only payable in favour of **Noida Metro Rail Corporation Limited** in the A/c No. mentioned in **Data Sheet**. The scanned copy of RTGS/NEFT receipt with transaction Id certified by the same bank must be enclosed along with the e-Bid. This cost of bid document/e-Tender processing fee as mentioned in **Data Sheet** will be non-refundable. Tender without cost of bid document/e-Tender processing fee in the prescribed form, will not be accepted.

3.1.2 Acknowledgement by Bidder

It shall be deemed that by submitting the e-Bid, the Bidder has:

- a. made a complete and careful examination of the e-Bid;
- b. received all relevant information requested from NMRC;
- c. acknowledged and accepted the risk of inadequacy, error or mistake in the information provided in the e-Bid or furnished by or on behalf of NMRC;
- d. satisfied itself about all matters, things and information, necessary and required for submitting an informed Application and performance of all its obligations there under;
- e. acknowledged that it does not have a Conflict of Interest; and
- f. Agreed to be bound by the undertaking provided by it under and in terms hereof.

3.1.3 Availability of Bid Document

This Bid document is available on the web site <http://etender.up.nic.in> or on Noida Metro website www.nmrcnoida.com to enable the Bidders to view, download the e-Bid document and submit e-Bids online up to the last date and time mentioned in e-Bidder notice/e-Bid document. The Bidders shall have to pay e-Bid document fee and EMD as mentioned in Data sheet through RTGS/NEFT on addresses given in data sheet. The scanned copy of RTGS/NEFT with transaction ID certified by the same bank must be enclosed along with the e-Bid. This e-Bid document fee will be non-refundable. Bid without Bid fee in the prescribe form will not be accepted.

3.1.4 Clarifications of e-Bid

- a. During evaluation of e-Bid, NMRC may, at its discretion, ask the Bidder for a clarification of his/her e-Bid. The request for clarification shall be in writing.

Any queries or request for additional information concerning this RFP shall be submitted in writing or by fax and e-mail to the CGM/Technical, NMRC **only before or during Pre-Bid Meeting** held at NMRC. The envelopes/ communication shall clearly bear the following identification/ title: **"Queries / Request Design, engineering, manufacture, supply, Installation, testing and commissioning of, 630KVA, 33KV/415V Compact Substation, Cabling and other accessories to be installed, its Integration with Existing NMRC SCADA at NMRC station KP-II, Pari Chowk.**

Design, engineering, manufacture, supply, Installation, testing and commissioning of, 630KVA, 33KV/415V Compact Substation, Cabling and other accessories to be installed, its Integration with Existing NMRC SCADA at NMRC station KP-II, Pari Chowk.

- b. .” The responses will be posted to all such queries on the official website www.nmrcnoida.com. NMRC reserves the right not to respond to any questions or provide any clarifications, in its sole discretion, and nothing in this Clause shall be taken or read as compelling or requiring NMRC to respond to any question or to provide any clarification.
- c. A pre-submission meeting shall be called on the date mentioned in **Data Sheet** at NMRC Office. Any change corresponding to date, if any, shall be communicated to the Bidder vide NMRC/ e-Tendering website.
- d. In case the Bidder seeks for any queries, he shall send letter or e-mail to the correspondence address given in Data Sheet.
- e. However, NMRC shall not entertain any correspondence from the Bidders during the period of e-Bid opening to selection of the successful Bidder. Any wrong practice shall be dealt under Fraud and Corrupt Practices.
- f. The Bidder is advised to visit and examine the Site of Works and its surroundings and obtain for himself on his own responsibility all information that may be necessary for preparing the Tender and entering into a contract for the proposed work. The costs of visiting the Site shall be borne by the Bidder. It shall be deemed that the Contractor has undertaken a visit to the Site of Works and is aware of the site conditions prior to the submission of the tender documents.
- g. The Bidder and any of his personnel will be granted permission by the Employer to enter upon his premises and lands for the purpose of such inspection, but only upon the express condition that the Bidder, and his personnel, will release and indemnify the Employer and his personnel from and against all liability in respect thereof and will be responsible for death or personal injury, loss of or damage to property and any other loss, damage, costs and expenses incurred as a result of the inspection.

3.1.5 Amendment of e-Bid Document

- a. At any time prior to the deadline for submission of e-Bid, NMRC may, for any reason, whether at its on in iterative or in response to a clarification requested by a prospective Bidder, modify the e-Bid document by amendments. Such amendments shall be uploaded on the e-procurement website <http://etender.up.nic.in> or NMRC's website www.nmrcnoida.com. The relevant clauses of the e-Bid document shall be treated as amended accordingly.
- b. It shall be the sole responsibility of the prospective Bidder to check the web site <http://etender.up.nic.in> or NMRC's website www.nmrcnoida.com from time to time for any amendment in the e-Bid documents. In case of failure to get the amendments, if any, NMRC shall not be responsible for it.
- c. In order to allow prospective e-Bids a reasonable time to take the amendment into account in preparing their e-Bids, NMRC, at the discretion, may extend the deadline for the submission of e-Bids. Such extensions shall be uploaded on the e-procurement website <http://etender.up.nic.in> or NMRC's website www.nmrcnoida.com.

3.2 Preparation and submission of Bids

3.2.1 Language of e-Bid

The e-Bid prepared by the Bidder, as well as all correspondence and documents relating to the e-Bid exchanged by the Bidder and NMRC shall be written in English language. Only English numerals shall be

Design, engineering, manufacture, supply, Installation, testing and commissioning of, 630KVA, 33KV/415V Compact Substation, Cabling and other accessories to be installed, its Integration with Existing NMRC SCADA at NMRC station KP-II, Pari Chowk.

used in the e-Bid. The correspondence and documents in any other language must be accompanied by transcripts verified by the Embassy of Home Country or equivalent.

3.2.2 Documents constituting the e-Bid

The e-Bid prepared by the Bidder shall comprise the following components:

a. Technical e-Bid- Technical e-Bid will comprise of -

- i. **Fee details** - Details of Bid processing fee and prescribed EMD
- ii. **Eligibility details** - Includes copies of required documents in PDF format justifying that the Bidder is qualified to perform the contract if his/her bid is accepted and the Bidder has financial & technical capability necessary to perform the contract and meets the criteria outlined in the Qualification requirement and technical specification and fulfil all the conditions of the contract.
- iii. **Technical evaluation** - Details of all documents needed for Technical evaluation as mentioned in this RFP

b. Financial e-Bid -

- i. **Price bid** – Bill of Quantities in XLS format to be filled in after downloading from the e-Procurement website for this e-tender. There shall be a single quote.

3.2.3 Documents establishing Bidder's Qualification

- a. The Bidder shall furnish, as part of its technical e-Bid, documents establishing the Bidder's qualification to perform the contract if its e-Bid is accepted. The documentary evidence should be submitted by the Bidder electronically in the PDF format.
- b. The documentary evidence of Bidder's qualification to perform the contract if its e-Bid is accepted shall be as per qualification requirements specified in e-Bid document.

3.2.4 E-Bid form

The Bidder shall complete the e-Bid form and the appropriate price schedule/BOQ furnished in the e-Bid document.

3.2.5 E-Bid Currency

Prices shall be quoted in Indian Rupees only.

3.2.6 Formats and Signing of e-Bid

- a. The Bidder shall prepare one electronic copy of the technical e-Bid and financial e-Bid separately.
- b. The e-Bid document shall be digitally signed, at the time of uploading, by the Bidder or a person or persons duly authorized to bind the Bidder to the contract. The later authorization shall be indicated by a scanned copy of written power-of attorney accompanying the e-Bid. All the pages/documents of the e-Bid that are to be uploaded shall be digitally signed by the person authorized to sign the e-Bid.
- c. Bidders should provide all the information as per the RFP and in the specified formats. NMRC reserves the rights to reject any proposal that is not in the specified formats.

Design, engineering, manufacture, supply, Installation, testing and commissioning of, 630KVA, 33KV/415V Compact Substation, Cabling and other accessories to be installed, its Integration with Existing NMRC SCADA at NMRC station KP-II, Pari Chowk.

- d. In case the Bidders intends to provide additional information for which specified space in the given format is not sufficient, it can be furnished in duly stamped and signed PDFs.

3.2.7 Deadline for submission of e-Bid

E-Bid (Technical and financial) must be submitted by the Bidder at e-procurement website <http://etender.up.nic.in> not later than the time specified on the prescribed date (as the server time displayed in the e-procurement website). NMRC may, at its discretion, extend this deadline for submission of e-Bid by amending the e-Bid document, in which case all rights and obligations of NMRC and Bidders previously subject to the deadline will thereafter be subject to the deadline as extended.

3.2.8 Submission of e-Bid

- a. The bid submission module of e-procurement website <http://etender.up.nic.in> enables the Bidders to submit the e-Bid online in response to this e-Bid published by NMRC.
- b. Bid submission can be done only from the bid submission start date and time till the bid submission end date and time given in the e-Bid. Bidders should start the bid submission process well in advance so that they can submit their e-Bid in time.
- c. The Bidder should submit their e-Bid considering the server time displayed in the e-procurement website. This server time is the time by which the e-Bid submission activity will be allowed till the permissible time on the last/end date of submission indicated in the e-Bid schedule.
- d. Once the e-Bid submission date and time is over, the Bidders cannot submit their e-Bid. For delay in submission of e-Bid due to any reasons, the Bidders shall only be held responsible.

The Bidders have to follow the following instructions for submission of their e-Bid:

- a. For participating in e-Bid through the e-Bidding system it is necessary for the Bidders to be the registered users of the e-procurement website <http://etender.up.nic.in>. The Bidders must obtain a user login Id and password by registering themselves with U.P. Electronics Corporation Ltd., Lucknow if they have not done so previously for registration.
- b. In addition to the normal registration, the Bidder has to register with his/her digital signature certificate (DSC) in the e-Bidding system and subsequently he/she will be allowed to carry out his/her e-Bid submission activities. Registering the digital signature certificate (DSC) is a one-time activity. Before proceeding to register his/her DSC, the Bidder should first log on to the e-Bidding system using the user login option on the home page with the login Id and password with which he/she has registered.

For successful registration of DSC on e-procurement website <http://etender.up.nic.in> the Bidder must ensure that he/she should possess class-2/class-3 DSC issued by any certifying authorities approved by controller of certifying authorities, Government of India, as the e-procurement website <http://etender.up.nic.in> is presently accepting DSC issued by these authorities only. The Bidder can obtain user login Id and perform DSC registration exercise given above even before the e-Bid submission date starts. NMRC shall not be held responsible if the Bidder tries to submit his/her e-Bid at the moment before end date of submission but could not submit due to DSC registration problem.

- c. The Bidder can search for active Bids through "search active tenders" link, select a Bid in which he/she is interested in and then move it to 'My Tenders' folder using the options available in the e-Bid submission menu. After selecting and the Bid, for which the Bidder intends to e-Bid, from

Design, engineering, manufacture, supply, Installation, testing and commissioning of, 630KVA, 33KV/415V Compact Substation, Cabling and other accessories to be installed, its Integration with Existing NMRC SCADA at NMRC station KP-II, Pari Chowk.

"My tenders" folder, the Bidder can place his/her e-Bid by clicking "pay offline" option available at the end of the view Bid details form. Before this, the Bidder should download the e-Bid document and price schedule/bill of quantity (BOQ) and study them carefully. The Bidder should keep all the documents ready as per the requirements of e-Bid document in the PDF format except the price schedule /bill of quantity (BOQ) which should be in the XLS format (excel sheet).

- d. After clicking the 'pay offline' option, the Bidder will be redirected to terms and conditions page. The Bidder should read the terms & conditions before proceeding to fill in the Bid fee and EMD offline payment details. After entering and saving the Bid fee and EMD details form so that "bid document preparation and submission" window appears to upload the documents as per technical (fee details, qualification details, e-Bid form and technical specification details) and financial (e-Bid form and price schedule/BOQ) schedules/packets given in the Bid details. The details of the RTGS/NEFT should tally with the details available in the scanned copy and the date entered during e-Bid submission time otherwise the e-Bid submitted will not be accepted.
- e. Next the Bidder should upload the technical e-Bid documents for fee details (e-Bid fee and EMD), Qualification details. Before uploading, the Bidder has to select the relevant digital signature certificate. He may be prompted to enter the digital signature certificate password, if necessary. For uploading, the Bidder should click "browse" button against each document label in technical and financial schedules/packets and then upload the relevant PDF/XLS files already prepared and stored in the Bidder's computer. The required documents for each document label of technical (fee details, qualification details, e-Bid form and technical specification details) and financial (e- Bid form and price schedule/BOQ) schedules/packets can be clubbed together to make single different files for each label.
- f. The Bidder should click "Encrypt" next for successfully encrypting and uploading of required documents. during the above process, the e-Bid documents are digitally signed using the DSC of the Bidder and then the documents are encrypted/locked electronically with the DSC's of the bid openers to ensure that the e-Bid documents are protected, stored and opened by concerned bid openers only.
- g. After successful submission of e-Bid document, a page giving the summary of e-Bid submission will be displayed confirming end of e-Bid submission process. The Bidder can take a printout of the bid summary using the "print" option available in the window as an acknowledgement for future reference.
- h. NMRC reserves the right to cancel any or all e-Bids without assigning any reason.

3.2.9 Late e-Bid

- a. Bids received by NMRC after the specified time on the Bid Due Date shall not be eligible for consideration and shall be summarily rejected.
- b. The server time indicated in the bid management window on the e-procurement website <http://etender.up.nic.in> will be the time by which the e-Bid submission activity will be allowed till the permissible date and time scheduled in the e-Bid.
- c. Once the e-Bid submission date and time is over, the Bidder cannot submit his/her e-Bid. Bidder has to start the bid submission well in advance so that the submission process passes off smoothly. The Bidder will only be held responsible if his/her e-Bid is not submitted in time due to any of his/her problems/faults, for whatsoever reason, during e-Bid submission process.

Design, engineering, manufacture, supply, Installation, testing and commissioning of, 630KVA, 33KV/415V Compact Substation, Cabling and other accessories to be installed, its Integration with Existing NMRC SCADA at NMRC station KP-II, Pari Chowk.

3.2.10 Withdrawal and resubmission of e-Bid

- a. At any point of time, a Bidder can withdraw his/her e-Bid submitted online before the bid submission end date and time. For withdrawing the Bidder should first log in using his/her login id and password and subsequently by his/her digital signature certificate on the e-procurement website <http://etender.up.nic.in>. The Bidder should then select "My bids" option in the bid submission menu. The page listing all the bids submitted by the Bidder will be displayed. Click "View" to see the details of the bid to be withdrawn. After selecting the "bid withdrawal" option the Bidder has to click "Yes" to the message "Do you want to withdraw this bid?" displayed in the bid information window for the selected bid. The Bidder also has to enter the bid withdrawing reasons and up- load the letter giving the reasons for withdrawing before clicking the "Submit" button. The Bidder has to confirm again by pressing "OK" button before finally withdrawing his/her selected e-Bid.
- b. No e-Bid may be withdrawn in the interval between the deadline for submission of e-Bids and the expiration of period of e- bid validity. Withdrawal of an e-Bid during this interval may result in the forfeiting of Bidder's e-Bid security.
- c. The Bidder can re-submit his/her e-Bid as when required till the e-Bid submission end date and time. The e-Bid submitted earlier will be replaced by the new one. The payment made by the Bidder earlier will be used for revised e-Bid and the new e-Bid submission summary generated after the successful submission of the revised e-Bid will considered for evaluation purposes. For resubmission, the Bidder should first log in using his/her login Id and password and subsequently by his/her digital signature certificate on the e-procurement website <http://etender.up.nic.in>. The Bidder should then select "My bids" option in the bid submission menu. The page listing all the bids submitted by the Bidder will be displayed. Click "View" to see the detail of the e-Bid to be re-submitted. After selecting the "bid resubmission" option, click "Encrypt & upload" to upload the revised e-Bids documents.
- d. The Bidder can submit their revised e-Bids as many times as possible by uploading their e-Bid documents within the scheduled date & time for submission of e-Bids.
- e. No e-Bid can be resubmitted subsequently after the deadline for submission of e-Bids.

3.2.11 NMRC's right to accept any e-Bid and to reject any or all e-Bids.

- a. Notwithstanding anything contained in this e-Bid, NMRC reserves the right to accept or reject any Bid and to annul the Selection Process and reject all Bids, at any time without any liability or any obligation for such acceptance, rejection or annulment, and without assigning any reasons thereof.
- b. NMRC reserves the right to reject any Bid if:
 - At any time, a material misrepresentation is made or uncovered, or
 - The Bidder does not provide, within the time specified by NMRC, the supplemental information sought by NMRC for evaluation of the e-Bid.
- c. Such misrepresentation/ improper response may lead to the disqualification of the Bidder. If such disqualification /rejection occurs after the e-Bid have been opened and the highest-ranking Bidder gets disqualified / rejected, then the NMRC reserves the right to consider the next best Bidder, or take any other measure as may be deemed fit in the sole discretion of NMRC, including annulment of the Selection Process.

Design, engineering, manufacture, supply, Installation, testing and commissioning of, 630KVA, 33KV/415V Compact Substation, Cabling and other accessories to be installed, its Integration with Existing NMRC SCADA at NMRC station KP-II, Pari Chowk.

3.2.12 Period of validity of e-Bid

- a. e-Bid shall remain valid for 180 days after the date of e-Bid opening prescribed by NMRC. An e-Bid valid for a shorter period shall be rejected by NMRC as non-responsive.
- b. In exceptional circumstances, NMRC may solicit the Bidder's consent to an extension of the period of e-Bid validity. The request and the response thereto shall be made in writing.

3.2.13 Correspondence with the Bidder

- a. Save and except as provided in this e-Bid, NMRC shall not entertain any correspondence with any Bidder or its Technical Partners in relation to acceptance or rejection of any e-Bid.
- b. Subject to Clause 3.4.5 no Bidders or its Technical Partners shall contact NMRC on any matter relating to his e-Bid from the time of Bid opening to the time contract is awarded.
- c. Any effort by the Bidder or by its Technical Partners to influence NMRC in the Bid evaluation, Bid comparison or contract award decisions, may result in the rejection of his Bid.

3.3 Earnest Money Deposit

3.3.1 Earnest money deposit (EMD)

- a. The Bidder shall furnish, as part of its e-Bid, an e-Bid security/ EMD as stated in Data Sheet in form of RTGS/NEFT only in favour Noida Metro Rail Corporation Limited in the A/c No. mentioned in **Data Sheet**. The scanned copy of RTGS/NEFT receipt of Security/ EMD with transaction Id certified by the same bank must be enclosed along with the e-Bid. Tender without Earnest Money in the prescribed form, will not be accepted.
- b. Any e-Bid not secured in accordance with above shall be treated as non-responsive and rejected by NMRC.
- c. Unsuccessful Bidder's EMD will be returned within 45 days of opening of the Price Bid in case of Conclusion or discharge of the tender.
- d. No interest will be paid by the Employer on the Earnest Money Deposit.
- e. The successful Bidder's e-Bid EMD will be adjusted with Performance Bank Guarantee, if applicable, to be submitted by the Bidder upon signing the contract.
- f. The EMD may be forfeited:
 - i. If Bidder (a) withdraws its e-Bid during the period of e-Bid validity specified by the Bidder on the e- bid form: or (b) does not accept the correction of errors or (c) modifies its e-Bid price during the period of e-Bid validity specified by the Bidder on the form.
 - ii. In case of a successful Bidder, if the Bidder fails to sign the contract with the Corporation.

3.4 Opening and Evaluation of Bids

3.4.1 Opening of technical e-Bid by NMRC

- a. NMRC will open all technical e-Bids, in the presence of Bidder's representatives who choose to attend on the prescribed date of opening at NMRC Office. The Bidder's representatives who are present shall submit the letter to NMRC on the letter head of the company stating that the representative (name) is authorized to attend the meeting (Please note – The representative is required to carry a copy during pre-bid and other related meetings as well). He / She shall sign a register evidencing their attendance at NMRC. In the event of the specified date e-Bid opening

Design, engineering, manufacture, supply, Installation, testing and commissioning of, 630KVA, 33KV/415V Compact Substation, Cabling and other accessories to be installed, its Integration with Existing NMRC SCADA at NMRC station KP-II, Pari Chowk.

being declared a holiday for the Corporation, the e -bids shall be opened at the appointed time and place on the next working day.

- b. The Bidder who is participating in e-Bid should ensure that the RTGS/NEFT of Bid Processing Fee and EMD must be submitted in the prescribed account of NMRC within the duration (strictly within opening & closing date and time of individual e-Bid) of the work as mentioned in Bid notice, otherwise, in any case, e-Bid shall be rejected.
- c. The Bidders names and the presence or absence of requisite e-Bid security and such other details as NMRC at its discretion may consider appropriate, will be announced at the opening.

3.4.2 Opening of financial e-Bid

- a. After evaluation of technical e-Bid, through the evaluation committee NMRC shall notify those Bidders whose technical e-Bids were considered non-responsive to the conditions of the contract and not meeting the technical specifications and qualification requirements indicating that their financial e-Bids will not be opened.
- b. NMRC will simultaneously notify the Bidders, whose technical e-Bids were considered acceptable to the Corporation. The notification may be sent by e-mail as provided by Bidder.
- c. The financial e-Bids of technically qualified Bidders shall be opened in the presence of technically qualified bidders who choose to attend. The date and time for opening of financial bids will be communicated to the technically qualified Bidders subsequently after completion of technical bids evaluation through e-mail provided by the Bidder.

3.4.3 Correction of Errors

- a. Financial Bids determined to be responsive will be checked by NMRC for any arithmetic errors. Where there is a discrepancy between the rate quoted in the Financial Bid, in figures and in words, the amount in words will prevail over the amounts in figures, to the extent of such discrepancy.
- b. The amount stated in the Financial Bid will be adjusted by NMRC in accordance with the above procedure for the correction of errors and shall be considered as binding upon the Bidder. If the Bidder does not accept the corrected quoted rate of e-Bid, his e-Bid will be rejected, and his Bid Security shall be liable for forfeiture in accordance with Clause 3.3.1f

3.4.4 Examination of e-Bid document

- a. The NMRC will examine the e-Bid to determine if:
 - i. They are complete;
 - ii. They meet all the conditions of the contract;
 - iii. The required e-Bid Processing fee, EMD and other required documents have been furnished;
 - iv. The documents have been properly digitally signed; and
 - v. The e-Bids are in order.
- b. Any e-Bid or e-Bids not fulfilling these requirements shall be rejected.

Design, engineering, manufacture, supply, Installation, testing and commissioning of, 630KVA, 33KV/415V Compact Substation, Cabling and other accessories to be installed, its Integration with Existing NMRC SCADA at NMRC station KP-II, Pari Chowk.

3.4.5 Contacting NMRC

- a. No Bidder shall contact NMRC on any matter relating to his/her e-Bid, from the time of the e-Bid opening to the time the contract is awarded. If the Bidder wishes to bring additional information to the notice of NMRC, he/she can do so in writing.
- b. Any effort by a Bidder to influence NMRC in its decisions on e-Bid evaluation, e- bid comparison or contract award may result in rejection of the Bidder's e-Bid.
- c. In the event of any information furnished by the Bidder is found false or fabricated, the minimum punishment shall be debarring /blacklisting from Noida Metro works and legal proceeding can also be initiated. EMD of such bidders will be forfeited.

3.4.6 Confidentiality

- a. Information relating to the examination, clarification, evaluation, and recommendation for the Bidders shall not be disclosed to any person who is not officially concerned with the process or is not a retained professional advisor advising NMRC in relation to or matters arising out of or concerning the Bidding Process. Any effort by a Bidder to exert undue or unfair influence in the process of examination, clarification, evaluation and comparison of Proposal shall result in outright rejection of the offer, made by the said Bidder.
- b. NMRC shall treat all information, submitted as part of Bid, in confidence and shall require all those who have access to such material to treat the same in confidence. NMRC may not divulge any such information unless it is directed to do so by any statutory entity that has the power under law to require its disclosure or is to enforce or assert any right or privilege of the statutory entity and/ or NMRC or as may be required by law or in connection with any legal process.

3.5 Award of Contract

3.5.1 Award Criteria

- a. NMRC will award the contract as per evaluation criteria stated in the RFP Document.
- b. NMRC will award the contract to the successful Bidder whose bid has been determined to be responsive to all the conditions of the contract and meeting the eligibility requirement of the bidding document.

3.5.2 Notice of Award (NOA)

- a. Prior to the expiration of the period of e-Bid validity, NMRC will notify the successful Bidder in writing, by letter/e-mail/fax, that its e-Bid has been accepted.
- b. The acceptance of NOA will constitute the formation of the contract.

3.5.3 Signing of contract

At the same time as NMRC notifies the successful Bidder that its e-Bid has been accepted, the successful Bidder shall have to sign the contract agreement with relevant document as mentioned in the RFP. The agreement draft along with other related terms and conditions will be same as furnished in this e-Bid. Any refusal will not be allowed. The Bidder need not download and submit in hard copies of these documents.

3.5.4 NMRC's right to accept any e-Bid and to reject any or all e-Bids

Design, engineering, manufacture, supply, Installation, testing and commissioning of, 630KVA, 33KV/415V Compact Substation, Cabling and other accessories to be installed, its Integration with Existing NMRC SCADA at NMRC station KP-II, Pari Chowk.

NMRC reserves the right to accept or reject any e-Bid, and to annul the e-Bid process and reject all e-Bids at any time prior to contract award, without thereby incurring any liability to the affected Bidder or Bidders.

Design, engineering, manufacture, supply, Installation, testing and commissioning of, 630KVA, 33KV/415V Compact Substation, Cabling and other accessories to be installed, its Integration with Existing NMRC SCADA at NMRC station KP-II, Pari Chowk.

4. Section 4: Qualification, Evaluation and Selection Process

4.1 Eligibility Criteria

The Bidder's competence and capability is proposed to be established by the following parameters. The Bidder should meet all the criteria given in this section.

- a. Sole proprietorship, registered partnership firm, public limited company, private limited company of any of the above can submit the Bidder. The firms and the companies should be registered in India.
- b. The Bidder should have a minimum experience of having satisfactorily completed similar works during last 7 (Seven) years period ending last day of month before the one in which the bids are invited should be either of the following:
 - i. One similar completed work costing not less than the amount equal to **Rs. 5.69 Crore** (Rupees Five Crore Sixty Nine Lacs only) or
 - ii. Two similar completed works each costing not less than the amount equal to **Rs. 3.56 Crore** (Rupees Three Crore Fifty Six Lacs only) or
 - iii. Three similar completed works each costing not less than the amount equal to **Rs. 2.85 Crore** (Rupees Two crore and Eighty-Five Lacs only)

Similar work" for this contract shall be "Supply/ installation testing and commission of 33 KV and above Auxiliary Sub-station" in NMRC/ any other Metro Organization/ Central govt./ State govt./PSU's/ Private sector companies of repute.

- c. T1 - Liquidity
Working capital/Net cash flow (Current Asset minus Current Liabilities) should be $\geq X/7$ in the last audited financial year.
- d. T2 - Profitability:
Profit before Tax should be positive in 2 years out of last 5 years.
- e. T3 - Net Worth:
Net worth should be $\geq X/5$ in the last audited financial year.
- f. The Bidder should have minimum average annual turnover in the last 5 (five) Financial Years (2018-19, 2019-20, 2020-21, 2021-22, 2022-23) preceding the Bid Due Date as follows:-

Average Annual Turnover from works should be $\geq 0.8X$

Note: Value of X would be calculated as under:

- a) For all tenders having completion period of 12 months or less, Value of 'X' = Approx. cost of work as given in NIT.
- b) For all Tenders having completion period of more than 12 months.

$$X = \frac{\text{Approx. cost of work as given in NIT}}{\text{Time of Completion in years}}$$

Design, engineering, manufacture, supply, Installation, testing and commissioning of, 630KVA, 33KV/415V Compact Substation, Cabling and other accessories to be installed, its Integration with Existing NMRC SCADA at NMRC station KP-II, Pari Chowk.

- g. The Bidder should not have been blacklisted/ banned/ declared ineligible for corrupt and fraudulent practices by the Government of India/ any State Government/ Government Agency and Supreme court and contracts have been terminated/ foreclosed by any company / department dueto non- fulfilment of Contractual obligation in last 5 (five) financial years.

The Bidder shall also furnish the following documentary proof (for all members in case of Consortium, as per eligibility criteria):

- a. For above criteria 4.1a
- i. Statutory proof of existence as the legal entity.
 - ii. PAN certificate as per legal entity
 - iii. Valid Electrical Contractor License
 - iv. GST RC
- b. For above criteria 4.1b
- i. Form 4: Work Experience with documentary evidence as mentioned in the Form
- c. For above criteria 4.1, c, d, e, f
- i. Form 5: Financial Capability Details
 - ii. A copy of the Audited balance sheets and Profit and Loss Statements for the last 5 (Five) financial years
In case the Financial Statements for the latest financial year are not audited and therefore the Bidder cannot make it available, the Bidder shall give an undertaking to this effect and the statutory auditor/chartered accountant shall certify the same. In such a case, the Bidder shall provide the Audited Financial Statements for 4 (Four) years preceding the year for which the Audited Financial Statement is not being provided. Also, pertaining to latest financial year, the bidder shall submit an affidavit certifying that "The Annual Accounts have not been audited so far we are submitting the audited provisional accounts which shall be substantiated by the audited accounts, when prepared."
 - iii. Self-attested copy of ITR of last five audited financial years.
- d. For above criteria 4.1g
- i. Form 7: Undertaking

4.2 Bid Capacity Criteria:

Bid Capacity: The Bidders will be qualified only if their available bid capacity is more than the approximate cost of work as per NIT. Available bid capacity will be calculated based on the following formula:

Bid capacity will be calculated based on the following formula:

$$\text{Available Bid Capacity} = 2 * A * N - B$$

Where,

A = Maximum of the value of work executed in any one year during the last five financial years (updated to the last day of the previous month of tender submission price level assuming 5% inflation for Indian Rupees every year and 2% for foreign currency portions per year).

N = No. of years prescribed for completion of the work

B = Value of existing commitments (as on the last day of the previous month of tender submission) for on-going works during period of 8 months w.e.f. from the first day of the month of tender submission.

Design, engineering, manufacture, supply, Installation, testing and commissioning of, 630KVA, 33KV/415V Compact Substation, Cabling and other accessories to be installed, its Integration with Existing NMRC SCADA at NMRC station KP-II, Pari Chowk.

Financial data for latest last five financial years has to be uploaded by the Bidder in Form-5 of Tender along with audited financial statements. The financial data in the prescribed format shall be certified by the Chartered Accountant with his **stamp and signature in original along with UDIN.**

Value of existing commitments for on-going works during period of 8 months w.e.f. from the first day of the month of tender submission has to be uploaded by the Bidder in **Form-13 of Tender.** These data shall be certified by the Chartered Accountant with his stamp and signature in original with UDIN.

4.3 Personnel

The Bidder shall submit - Form 11: Undertaking pertaining to Personnel a staffing schedule containing the names, qualifications, professional experience and corporate affiliation of all proposed management personnel (above the level of shift supervisor) and specialists for this work. The sub- mission shall include a provisional management structure and organisation chart showing areas of responsibility, relative seniorities and lines of reporting.

RESOURCES PROPOSED FOR THE PROJECT – PERSONNEL

The figures indicated below are the minimum number of Project-Personnel required which are to be deployed as per the minimum level of supervision and qualification/experience of site staff is given as follows:

S. No.	Designation of Project Personnel	Minimum Requirement
1	Civil Engineer/Site Engineer	1
2	Electrical Engineer/Site Engineer having Degree in relevant field and at least 07 years of experience in power substation project or maintenance also worked on SCADA system.	1
3.	Engineer/Site Engineer having at least 5 years of experience in SCADA system.	1
4	Bill Engineer	1
5.	Project Supervisor at least three years experience in similar work	2 (one from each department)

It is to be noted that:

Design, engineering, manufacture, supply, Installation, testing and commissioning of, 630KVA, 33KV/415V Compact Substation, Cabling and other accessories to be installed, its Integration with Existing NMRC SCADA at NMRC station KP-II, Pari Chowk.

- i. The contractor shall deploy resources as per the above-mentioned minimum requirement and also confirm to deploy manpower over and above the minimum numbers indicated above, if the work requires so and submit their valid experience and qualification documents for approval.
- ii. These minimum resources are as per the requirements of the various activities at different stages of works. All resources need not to be mobilized simultaneously, resources as per the requirement of various stages of works shall be mobilized in accordance with the instructions of the Engineer. The decision of the Engineer shall be final and bonding.
- iii. The performance of project personal deployed will be evaluated periodically by Employer during the contract period. In case the performance of any of the personnel is not satisfactory, the contractor shall replace them with good personnel immediately as per the directions of the Engineer.
- iv. **If staff is absent or found missing from his period of duty during ongoing work, recovery @ ₹5000/- for supervisor and @ ₹10000/- for engineer per day shall be imposed on the contractor and to be recovered from the running bill of the contractor.**

4.4 Compliance with Technical Specifications

The Bidders must comply with the stipulated technical specifications as mentioned in the tender documents

4.5 Information of the Technical and Financial Proposal

- a. The Bidder satisfying technical and financial eligibility criteria under Clause 4.1 shall be considered as technically and financially qualified.
- b. The financial proposal of only technically qualified Bidders shall be opened for evaluation.
- c. The Bidder with the lowest quoted price for the RFP for Design, engineering, manufacture, supply, Installation, testing and commissioning of, 1000KVA, 33KV/415V Compact Substation, Cabling and other accessories to be installed at NMRC station sector-51, Noida in the financial quote (**L1 bidder**) shall be selected for the award of contract.

4.6 Selection of Bidder

After the above evaluation process, the Technically Qualified Bidder, who is declared as **L1 (lowest quoted price)** may be declared as the selected Bidder ("Selected Bidder") for the Project.

- a. In case, two or more technically qualified bidders quote the same rate in the Commercial Bid, and become Lowest (i.e. L-1), then the tender would be awarded to the bidder who has the highest / higher Average Annual Turnover from 'Similar Works' (as per Minimum Eligibility Criteria defined in Section 4 under "Definition of Similar Work") during the last 3 years ending on the last day of the month preceding the month in which the tender has been floated. Experience certificate / work completion certificate on client's letter head is mandatory to ascertain the nature, period and value of work which shall be required to be uploaded by the bidder by the last date of tender submission. Prior to the expiry of the period of bid validity, NMRC will notify the successful bidder in writing, either through Notice of Award (NOA), that his bid has been accepted.
- b. Prior to the expiry of the period of bid validity, NMRC will notify the successful bidder in writing, either through Notice of Award (NOA), that his bid has been accepted.

Design, engineering, manufacture, supply, Installation, testing and commissioning of, 630KVA, 33KV/415V Compact Substation, Cabling and other accessories to be installed, its Integration with Existing NMRC SCADA at NMRC station KP-II, Pari Chowk.

- c. The NOA would be sent in duplicate to the successful bidder, who will return one copy to NMRC duly acknowledged, signed and stamped by the authorized signatory of the bidder, as an unconditional acceptance of the NOA, within 10 (ten) days from the date of issue of NOA.
- d. No correspondence will be entertained by NMRC from the unsuccessful bidders.

4.7 Notice of Award and Execution of Contract Agreement

- a. NMRC will notify the Successful Bidder by a Notice of Award (NOA) that its bid has been accepted.
- b. The Selected Bidder shall, within 10 (ten) days of the receipt of the NOA, sign and return the duplicate copy of the NOA in acknowledgement thereof along with letter of acceptance of NOA. In the event, the duplicate copy of the NOA duly signed by the Selected Bidder and letter of acceptance of NOA is not received by the stipulated date, NMRC may, unless it consents to extension of time for submission thereof, appropriate the Bid Security of such Bidder as mutually agreed genuine pre-estimated loss and damage suffered by NMRC because of failure of the Selected Bidder to acknowledge the NOA
- c. The Successful Bidder shall execute the Contract Agreement within **30 (Thirty) days** of the letter of acceptance of NOA or such extended period as may be decided by the Corporation.
- d. Failure of the Successful Bidder to comply with the requirement of acknowledgement of NOA shall constitute sufficient grounds for the annulment of the NOA, and forfeiture of the bid security.
- e. The Purchaser reserves the right to increase or decrease the quantity up to 25% of the quantity offered by the successful Bidder. The bidder is bound to accept the increase or decrease in the tendered quantity up to 25% under this clause without any change in unit price.

In case the variation in individual items or the group of items as stipulated above, is more than 25% on plus side, the rate for the varied quantity beyond 25% shall be negotiated between NMRC and the Contractor and mutually agreed rates arrived at before actual execution of the extra quantity. In case the contractor executes the extra quantity without written approval of the NMRC with specific instructions to execute pending the finalization of rates, the payment shall be made at contract rate only. In the event of disagreement, the Engineer shall fix such rates of price as are, in his opinion appropriate and shall notify the Contractor accordingly, with a copy to the Employer. Until such time as rates or prices are agreed or fixed, the Engineer shall determine provisional rates or prices to enable on account payments to the Contractor. Alternatively, in the event of disagreement, the Contractor shall have no claim to execute extra quantities/new items and the Engineer shall be free to get such additional quantities beyond 25% new items executed through any other agency. However, if the Engineer or the Employer so directs the Contractor shall be bound to carry out any such additional quantities beyond the limits stated above original quantities and or new items and the disagreement or the difference regarding rates to be paid for the same shall be settled in the manner laid down under the conditions for the settlement of dispute.

4.8 Performance Bank Guarantee / Security Deposit

- a. To fulfil the requirement of performance bank guarantee during the implementation period, the Successful Bidder (herein referred to as the "Contractor") shall deposit **10% of the Contract Price** in form of FDR/ DD/ RTGS/ NEFT or unconditional and irrevocable Bank Guarantee bond issued by a scheduled bank in favour of Noida Metro Rail Corporation Limited, within 30 days from Notice of Award. EMD amount of successful bidder shall be adjusted in the performance bank guarantee, if applicable. For unsuccessful bidder, EMD shall be refunded without any interest. The Performance Guarantee should be valid for a period of three (3) months beyond the

Design, engineering, manufacture, supply, Installation, testing and commissioning of, 630KVA, 33KV/415V Compact Substation, Cabling and other accessories to be installed, its Integration with Existing NMRC SCADA at NMRC station KP-II, Pari Chowk.

Defect Liability Period and will be released after successful completion of Defect Liability Period.

- b. It is to note that if contract value increases by more than 25% of the original contract value, the performance bank guarantee shall be increased accordingly.
- c. A Contract agreement will have to be signed by the Contractor at his cost on proper stamp paper. Without performance guarantee by Contractor, Contract agreement shall not be signed.
- d. NMRC reserves the right for deduction of NMRC dues from Contractor's Performance Bank Guarantee/ Security Deposit (interest free) for –
 - I. Any penalty imposed by NMRC for violation of any terms and conditions of agreement committed by the Contractor.
 - II. Any amount which NMRC becomes liable to the Government/Third party due to any default of the Contractor or any of his director/ employees/ representatives/ servant/ agent, etc.
 - III. Any payment/ fine made under the order/judgment of any court/consumer forum or law enforcing Contractor or any person duly empowered in his behalf.
 - IV. Any outstanding payment/ claims of NMRC remained due after completion of relevant actions as per agreement.
- e. Once the amount under above Clause is debited, the Contractor shall replenish the Security Deposit/ Performance Bank Guarantee to the extent the amount is debited within 15 days period, failing which, it shall be treated as Contractor Event of Default and will entitle NMRC to deal with the matter as per the provisions of RFP and Contract Agreement.
- f. **The Bank Guarantee must be issued by a bank branch located in Delhi/NCR, Noida and Greater Noida region only. The Bank guarantee shall be extended and renewed in advance before expiry of existing bank guarantee.**

4.9 Contract during Proposal Evaluation

- a. Proposals shall be deemed to be under consideration immediately after they are opened and until such time NMRC makes official intimation of award/ rejection to the Bidders. While the Proposals are under consideration, Bidders and/ or their representatives or other interested parties are advised to refrain from contacting by any means, NMRC and/ or their employees/ representatives on matters related to the Proposals under consideration till the time Contract is awarded.
- b. Any effort by a Bidder to influence NMRC in its decisions on e-Bid evaluation, e-Bid comparison or contract award may result in rejection of the Bidder's e-Bid.
- c. In the event of any information furnished by the Contractor is found false or fabricated the minimum punishment shall be debarred/ blacklisting and the legal proceeding may also be initiated.
- d. If the Bidder wishes to bring additional information to the notice of NMRC, he/she can do so in writing. All correspondence/ enquiry should be submitted to the following in writing by fax/ post/courier:

ED

Noida Metro Rail Corporation (NMRC) Limited
Block-III, 3rd Floor, Ganga Shopping Complex, Sector-29,

Design, engineering, manufacture, supply, Installation, testing and commissioning of, 630KVA, 33KV/415V Compact Substation, Cabling and other accessories to be installed, its Integration with Existing NMRC SCADA at NMRC station KP-II, Pari Chowk.

Noida -201301
District Gautam Budh Nagar, Uttar Pradesh
Email: nmrcnoida@CGMail.com, nmrcrsandel@gmail.com

- e. No interpretation, revision, or other communication from NMRC regarding this solicitation is valid unless in writing and signed by the competent authority from NMRC.

4.10 Other Instruction

- a. Canvassing in connection with the tenders is strictly prohibited and the tenders, submitted by Bidder, who resort to canvassing, are liable to be rejected. EMD will be forfeited of those tenders who will be found non-serious and if it is felt by the tender committee that the Bidders submitted their tender only to influence the tendering process.
- b. On acceptance of the tender, the name of the accredited representative of the Contractor, who would be responsible for taking instructions from NMRC or the official deputed by NMRC, shall be communicated to NMRC or the official deputed by NMRC in writing.

4.11 Project Financial Terms

4.11.1 Payment Terms

- a. The payment for items given in Bill of Quantity/Pricing Document shall be made based as per SCC clause S. No-23, **Sub-Clause 11.6.**
- b. The work executed against the BOQ items in would be paid on measurement basis.
- c. The Contractor may raise their 'On Account'' payments on monthly basis as per the status of work on the last day of the respective month.

4.12 Contractor's Labour Camp

4.12.1 Employer not to provide Quarters for Contractor's Labour

The Employer will not provide living accommodation for the use of the Contractor or any of his staff or labour employed on the Works. Living accommodation shall not be established on any land provided to the contractor by the Employer.

4.12.2 Provision of Labour Camp

The Contractor, shall, at his own expense, make adequate arrangements for the housing, supply of drinking water and provision of bathrooms, latrines and urinals, with adequate water supply, for his staff and workmen directly or through sub-contractors employed on the Works at the location authorised by Engineer. No labour camp shall be allowed at work site or any unauthorised place. The Contractor at his own cost shall maintain all campsites in a clean and sanitary condition. The Contractor shall obey all health and sanitary rules and regulations and carry out at his cost all health and sanitary measures that may, from time to time, be prescribed by the Local/Medical Authorities and permit inspection of all health and sanitary arrangements at all times by the Employer, Engineer and the staff of the local municipality or other authorities concerned. Should the Contractor fail to provide adequate health and sanitary arrangements these shall be provided by the Employer and the cost recovered from the Contractor. The Contractor shall at his own cost, provide First Aid and Medical facilities at the Labour Camp and at work sites on the advice of the Medical Authority in relation to the strength of the Contractor's staff and workmen, employed directly or through sub-contractors. The Contractor shall at his own cost, provide the following minimum requirements for fire precautions:

- Portable Fire Extinguishers

Design, engineering, manufacture, supply, Installation, testing and commissioning of, 630KVA, 33KV/415V Compact Substation, Cabling and other accessories to be installed, its Integration with Existing NMRC SCADA at NMRC station KP-II, Pari Chowk.

- Manual Fire Alarms
- Water Supply for use by the Fire Service.

The Contractor at his own cost shall provide necessary arrangements for keeping the camp area sufficiently lighted to avoid accidents to the workers. He should also ensure that electrical installations are done by Trained Electricians. These installations shall be maintained, and daily maintenance records must be made available for inspection of the Engineer.

4.12.3 Camp Discipline

The Contractor shall take requisite precautions and use his best endeavours to prevent any riotous or unlawful behavior by or amongst his workmen, and others, employed directly or through sub-contractors. These precautions shall be for the preservation of the peace and protection of the inhabitants and security property in the neighbourhood of the Works. In the event of the Employer requiring the maintenance of a Special Police Force at or near the site, during the tenure of the work, the expenses thereof shall be borne by the Contractor and if paid by the Employer, shall be recoverable from the Contractor. The sale of alcoholic drinks or other intoxicating drugs or beverages upon the work, in any labour camp, or in any of the buildings, encampments or tenements owned or occupied by, or within the control of, the Contractor or any of his employees directly or through subcontractors employed on the work, shall be forbidden, and the Contractor shall exercise his influence and authority to secure strict compliance with this condition. The Contractor shall also ensure that no labour or employees are permitted to work at the site in an intoxicated state or under the influence of drugs. The Contractor shall remove from his camp such labour and their families, as refuse protective inoculation and vaccination when called upon to do so by the Engineer on the advice of the Medical Authority. Should Cholera, Plague or any other infectious disease break out, the Contractor shall at his own cost burn the huts, bedding, clothes and other belongings of or used by the infected parties. The Contractor shall promptly erect new huts on healthy sites as required by the Employer, within the time specified by the Employer, failing which the work may be done by the Employer and the cost recovered from the Contractor.

4.12.4 Labour Accommodation

The Contractor shall provide living accommodation that is equal to or exceeds the minimum criteria established in the following sub-sections, needed to house his staff, workers employed directly or through sub-contractors. The buildings shall be constructed to have a minimum life of not less than the length of the Contract.

- a. The roofs shall be watertight and laid with suitable non-flammable materials permissible for residential use under local regulations and for which the consent of the Engineer has been obtained.
- b. Each hut shall have suitable ventilation. All doors, windows, and ventilators shall be provided with security leaves and fasteners. Back-to-back units may be avoided.
- c. The minimum height of each unit shall be 2.10m and shall have separate cooking place.
- d. Suitable no. of common toilet/bath shall be provided.

4.12.5 Water Supply

The Contractor shall provide an adequate supply of water for the use of labourers in the Camp. The provision shall not be less than two gallons of pure and wholesome water per head per day for drinking purposes and three gallons of clean water per head per day for bathing and washing purposes. Where piped water supply is available, supply shall be at stand posts and where the supply is from wells or river, tanks which be of metal or masonry shall be provided. The Contractor shall also at his expense plan for the

Design, engineering, manufacture, supply, Installation, testing and commissioning of, 630KVA, 33KV/415V Compact Substation, Cabling and other accessories to be installed, its Integration with Existing NMRC SCADA at NMRC station KP-II, Pari Chowk.

provision and laying of water pipe lines from the existing mains wherever available and shall pay for all the fees and charges thereof.

4.12.6 Drainage

The Contractor shall provide efficient arrangements for draining away sewage water to keep the camp neat and tidy. Surface water shall be drained away from paths and roads and shall not be allowed to accumulate into ditches or ponds where mosquitoes can breed.

4.12.7 Sanitation

The Contractor shall arrange for conservancy and sanitation in the labour camps according to the rules and regulations of the Local Public Health and Medical Authorities. The Contractor shall provide a sewage system that is adequate for the number of residents in the camp, and which meets the requirements of the Municipality Authorities.

Design, engineering, manufacture, supply, Installation, testing and commissioning of, 630KVA, 33KV/415V Compact Substation, Cabling and other accessories to be installed, its Integration with Existing NMRC SCADA at NMRC stations KP-II, Pari Chowk.

5. Section 5: Special Conditions of Contract (SCC)

SCC Clause	Reference to GCC Sub-Clause No.	Description
1	Sub-Clause 3.2	<p>Functions of Engineer</p> <p>In addition to the duties mentioned in Clause 3.2 of General Conditions of Contract:</p> <p>(i) Shall watch and inspect the Works, monitor and examine any material to be used and workmanship employed by the Contractor in connection with the Works;</p> <p>(ii) Shall carry out such duties and exercise such powers vested in the Engineer in accordance with the provisions of the Contract;</p> <p>(iii) Shall issue instructions which in his opinion are necessary for the execution of the Works; and</p> <p>(iv) May issue any other instruction which in his opinion is desirable in connection with the Works.</p> <p>In case The Engineer is employee of any agency hired by the Employer, the Engineer shall take the approval of the Employer for all technical and financial matters otherwise he shall be deemed to have taken the approval of the Employer.</p>
2	Sub Clause 4.2.1	<p>PERFORMANCE SECURITY</p> <p>This Clause is deleted in SCC & GCC Clause is applicable.</p>
3	Sub-Clause 4.4	<p>Coordination with other Contractors</p> <p>The contractor shall plan and execute work in coordination and in co-operation with other contractors working for adjacent.</p>
4	Sub-clause 4.5	<p>Sub-contractors</p> <p>The work should not be sublet.</p>
5	Sub-Clause 4.10	<p>Sufficiency of Tender</p> <p>The Bidder shall be entirely responsible for sufficiency of rates quoted by him in his tender.</p> <p>The Contractor (Successful Bidder) shall be paid for only at quoted/accepted rates for the items of works executed as per BOQ.</p>
6	Sub-Clause 4.11	<p>Access Route</p> <p>All operations for the execution of the Works shall be carried out so as not to interfere unnecessarily with the convenience of the public or the access to public or private roads or footpaths or properties owned by the Employer or by any other person.</p> <p>The Contractor shall select routes, choose and use vehicles so that movement of Contractor's Equipment, Plant and Materials from and to the Site is limited so that traffic is not delayed and damage to highways and bridges is prevented. If there is any delay or damage or injury, the cost of rectification or reconstruction of highways or bridges shall be borne by the Contractor. The Contractor shall indemnify the Employer in respect of all claims, demands, proceedings, damages, costs, charges and expenses whatsoever arising out of or in relation to any such matters</p>
8	Sub-Clauses 4.16 and 6.7	<p>Safety Precautions</p> <p>The Contractor is required to make himself aware of all the requirements of the Employer's Safety, Health and Environmental Manual in this regard and comply with them. The Site Safety Plan shall include detailed policies, procedures and regulations which, when implemented, will ensure compliance with Sub-</p>

Design, engineering, manufacture, supply, Installation, testing and commissioning of, 630KVA, 33KV/415V Compact Substation, Cabling and other accessories to be installed, its Integration with Existing NMRC SCADA at NMRC station KP-II, Pari Chowk.

SCC Clause	Reference to GCC Sub-Clause No.	Description
		<p>Clauses 4.16 and 6.7 of General Conditions of Contract.</p> <p>The Contractor shall, from time to time and as necessary or required by the Engineer, produce supplements to the Site Safety Plan such that it is at all times a detailed, comprehensive and contemporaneous statement by the Contractor of his site safety and industrial health obligations, responsibilities, policies and procedures (under the laws of India) or as stated in the Contract or elsewhere relating to work on Site If at any time the Site Safety Plan is, in the opinion of the Engineer, insufficient or requires revision or modification to ensure the security of the Works and the safety of all workmen upon, and visitors to the Site, the Engineer may instruct the Contractor to revise the Site Safety Plan. The Contractor shall, within 14 days, submit the revised plan to the Engineer for review.</p>
9	Sub-Clause 4.17	<p>Protection of the Environment</p> <p>The Contractor shall maintain ecological balance by preventing deforestation, water pollution and defacing of natural landscape. The Contractor shall, so conduct his cleaning operations, as to prevent any avoidable destruction, scarring or defacing of natural surroundings in the vicinity of work. In respect of ecological balance, the Contractor shall observe the following instructions</p> <p>(a) Where destruction, scarring, damage or defacing may occur as a result of operations relating to construction and maintenance activities, the same shall be repaired, replanted or otherwise corrected at Contractor's expense. All work areas shall be smoothed and graded in a manner to confirm to natural appearance of the landscape as directed by the Engineer.</p> <p>(b) All trees and shrubbery, which are not specifically required to be cleared or removed for cleaning purposes, shall be preserved and shall be protected from any damage that may be caused by Contractor's cleaning operations and equipment. The removal of trees or shrubs will be permitted only after prior approval by the Engineer. Trees shall not be used for anchorage. The Contractor shall be responsible for injuries to trees and shrubs caused by his operations. The term "injury" shall include, without limitation, bruising, scarring, tearing and breaking of roots, trunks or branches. All injured trees and shrubs shall be restored as nearly as practicable, without delay, to their original condition at Contractor's expenses.</p> <p>(c) The Contractor shall provide all necessary access, assistance and facilities to enable the Engineer and the Employer to monitor and conduct tests to verify that the Site Environmental Plan is being properly and fully implemented</p>
10	Sub-Clause 4.18	<p>Electricity and Water</p> <p>Electricity and water shall be arranged by the contractor on his own and at his cost.</p> <p>If available, the Employer may provide Water supply and Electricity on chargeable basis. The contractor shall make his own arrangements to tap the Electricity from the nominated and existing sockets/ points. The contractor shall tap</p>

Design, engineering, manufacture, supply, Installation, testing and commissioning of, 630KVA, 33KV/415V Compact Substation, Cabling and other accessories to be installed, its Integration with Existing NMRC SCADA at NMRC station KP-II, Pari Chowk.

SCC Clause	Reference to GCC Sub-Clause No.	Description
		<p>the Electricity as per IE Rules & IE Act (Latest) duly complying all safety precautions and under following conditions:</p> <p>(a) The contractor shall submit full scheme for the requirement of Electricity & water. If scheme mentions Electricity requirement which is beyond the capacity of the Employer, in that case the contractor shall make his own arrangements/ alternative arrangements.</p> <p>(b) The Contractor should make his own arrangements to draw the water from the available water point to the working place without affecting the premises</p>
11	Sub-Clause 4.19	<p>Employer Supplied Machinery and Materials The Employer will not provide any machinery or materials under the Contract.</p>
12	Sub Clause 4.27	<p>Security of the Site The Contractor shall take all measures necessary to ensure such security, including exercising control over all persons and vehicles which are employed or engaged on the Site or in connection with the Works or the other works comprising the Project and with the security arrangements applicable to any other site within the Project.</p> <p>The Contractor shall arrange the issue of passes for the admission of all persons and vehicles to the Site or to any part thereof and may refuse admission to or remove from the Site any person or vehicle failing to show an appropriate pass on demand to any duly authorised person.</p> <p>If required by the Engineer, the Contractor shall submit a list identifying all persons to whom passes have been issued together with two photographs of each person and all entities to which a pass has been issued in respect of any vehicle and shall satisfy the Engineer of the bonafides of any such person or entity.</p> <p>The Contractor shall not, without the written permission of the Engineer or otherwise in accordance with the Contract, allow access to the Site to any person unless the presence on Site of such person is necessary in connection with the execution of the Works or with the discharge of the duties of any relevant authority.</p> <p>For the purposes of this Clause only, "Site" shall include off-Site places of manufacture or storage and the Contractor's Work Areas and shall include, areas provided to the Contractor by others.</p>
13	Sub-Clause 5.3	<p>Submission of Documents The Contractor shall submit scheme of work, drawings and documents, as required by the Contract, to the Engineer in accordance with any submittal schedule agreed with the Engineer. This submittal shall be made sufficiently before the Works are to be carried out to give the Engineer and the Employer reasonable time to examine the drawings or other documents, to prepare comments and for any changes to be accommodated by the Contractor.</p> <p>Where the consent of the Engineer is required, the Engineer shall notify the</p>

Design, engineering, manufacture, supply, Installation, testing and commissioning of, 630KVA, 33KV/415V Compact Substation, Cabling and other accessories to be installed, its Integration with Existing NMRC SCADA at NMRC station KP-II, Pari Chowk.

SCC Clause	Reference to GCC Sub-Clause No.	Description
		<p>Contractor in writing of his decision either within such period as may expressly be stipulated in the Contract or otherwise within a reasonable time.</p> <p>The Operation and Maintenance Manuals and drawings submitted by the Contractor shall, if required, be updated by him during the Defects Liability Period and re-submitted for review by the Employer's Representative.</p>
15	Sub-Clause 6.4	<p>Labour Laws</p> <p>The Contractor shall, if required by the Employer, deliver to the Engineer or to his office; a return in detail, in such form and at such intervals as the Employer may prescribe, showing the number of labours employed in different categories by the Contractor for the entire work.</p> <p>The contractor must ensure compliance of all the labour laws including obtaining labour licence and registration of workers with BOCW Board.</p>
16	Sub-Clause 6.6	<p>Housing Facilities</p> <p>The Contractor shall have to make his own arrangements for housing facilities for his staff.</p>
17	Sub-Clause 6.7	<p>Health and Safety</p> <p>Contractors are required to take care of his labour/site staff working at site if any mishappening occurred.</p>
18	Sub Clause 7.0	<p>Quality Control</p> <p>The Contractor shall appoint a suitably qualified and experienced person, not otherwise engaged in the performance of the Contract, to act as manager of the quality assurance system and shall provide such other personnel and resources as required to ensure effective operation of the quality assurance system. The said manager shall carry out audits of the application of the quality assurance system and ensure effective quality control and delivery of quality assurance.</p> <p>The Contractor shall provide all necessary access, assistance and facilities to enable the Engineer to carry out surveillance visits both on and off the Site to verify that the quality assurance system is being properly and fully implemented. No extra payment shall be made in this regard and the cost of the Work under this element shall be deemed to be included in the Contract Price.</p>
19	Sub Clause 10.1	<p>Defect liability period</p> <p>The Defect liability period (DLP) shall be 24 months from the date of issue of the latest Taking over Certificate for the whole of the works.</p> <p>Work by persons other than the Contractor.</p> <p>If by reason of any accident or failure or other event occurring to, in, or in connection with the Works any remedial or other work shall, in the opinion of the Engineer, be urgently necessary and the Contractor is unable or unwilling at once to do such remedial or other work, the Engineer may authorise the carrying out of such remedial or other work by a person other than the Contractor. If the remedial or other work so authorised by the Engineer is work, which, in the Engineer's opinion, the Contractor was liable to do under the defect liability period Contract, all expenses properly incurred in carrying out the same shall be recoverable by the Employer from the Contractor, provided that the Engineer shall, as soon after the occurrence of any such emergency as may be reasonably practicable, notify the Contractor thereof in writing.</p>

Design, engineering, manufacture, supply, Installation, testing and commissioning of, 630KVA, 33KV/415V Compact Substation, Cabling and other accessories to be installed, its Integration with Existing NMRC SCADA at NMRC station KP-II, Pari Chowk.

SCC Clause	Reference to GCC Sub-Clause No.	Description
20	<p>Sub-Clause 11.1</p> <p>Sub-Clause 11.1.1</p> <p>Sub-Clause 11.1.4</p>	<p>Contract Price & Payment</p> <p>In respect of All-Inclusive Contract The Contract Price, subject to any adjustment thereto in accordance with the contract conditions, shall be all inclusive (including all taxes, duties, royalties etc.)</p> <p>Change in Taxes Duty (a) "Change in Taxes/Duties/Levies" means the occurrence or coming into force of the following, at any time after the date of submission of tender. (i) Any new tax which is imposed on Composite Works Contractors applicable on Metro Project. (ii) Change in the rate of GST on Composite Works Contractors applicable on Metro Project as Per GST Act.</p> <p>(b) The Contract Price shall be adjusted due to any of the above two conditions. Adjustment in contract price will be applicable up to the stipulated date of completion of work including the extended period of completion where such extension has been granted under sub clause 8.4.1 of GCC or it is specifically mentioned that extension is with adjustment for changes as stated above.</p> <p>(c) If the extension of contract period is on account of contractor's fault under Sub-clause 8.4.3 of GCC, no compensation shall be made towards upward revision towards "change in Taxes/Duty (taking place during the said extended contract period)" as mentioned at Sl. No. (a) (i) & (ii) above, during the original contract period or extended contract period shall be on employer's account.</p> <p>(d) Any other changes (except on account of clause (a) (i) & (ii) above) in existing taxes/new taxes on supply of materials/services/works etc. will not be considered and its impact shall be considered covered in the price variation clause provided in the Contract and in Contract where Price Variation clause is not provided, the impact on any other change (except on account of clause (a) (i) & (ii) above) in existing taxes/new taxes on supply of materials/services/works etc. will be deemed to be included in the quoted contract price.</p> <p>(e) Also, the contract price shall not be adjusted on account of fluctuations in the rates of exchange between the foreign currencies of the contract and Indian rupees from the last date of submission of tender.</p>
21	<p>Sub clause 11.1.3</p>	<p>Price Variation This is a fixed price contract and no Price Variation is admissible in this contract.</p>
22	<p>Sub-Clause 11.2</p>	<p>Advance No Advance is admissible in this contract.</p>

Design, engineering, manufacture, supply, Installation, testing and commissioning of, 630KVA, 33KV/415V Compact Substation, Cabling and other accessories to be installed, its Integration with Existing NMRC SCADA at NMRC station KP-II, Pari Chowk.

SCC Clause	Reference to GCC Sub-Clause No.	Description
23	Sub-Clause 11.6	<p>Payment For the purpose of On-account payment, the contractor shall submit detailed activities carried out as per BOQ recorded in Measurement sheets, Abstract sheets along with recorded bill for the item actually executed for checking and payment. Payment will be affected based on unit rates as approved in the Bill of Quantities.</p> <p>Payment Instalments and ratio:</p> <p>a) Scheme approval and delivery of supply of item: 60% of the cost may be released after successful delivery of electrical items on site on foundation.</p> <p>b) Installation and testing and commissioning: 20% of the charges may be released after installation including earthing, electrical cabling & approvals.</p> <p>c) Final approval, Integrated Testing & commissioning: 20% remaining charges, may be released after</p> <ul style="list-style-type: none"> a) Integrated Testing and Commissioning of CSS. b) Three sets of completion drawings and one set drawing on rubber sheet comprising the following shall be submitted by the contractor while handing over the installation/ before EIG inspection. <ul style="list-style-type: none"> ▪ Equipments layout drawing(s) giving complete details of the entire equipments. Electrical drawings for the entire electrical equipments showing cable sizes, equipment capacities, switch-gear's ratings, control components, control wiring etc. c) <u>No Objection Certificate from CHIEF ELECTRICAL INSPECTOR TO THE GOVERNMENT OF INDIA for the metro work.</u> d) Training of operation and maintenance staff of the NMRC to be provided by contractor. e) At the time of final completion, the contractor shall arrange for inspection and testing of the installation. Test results obtained shall be recorded. The installation shall not be accepted until it complies with the requirement of these Specifications. The Sub Station installation shall be got inspected by the contractor from CHIEF Electrical Inspector for metro work and their clearance taken before energizing the Sub Station. All the observations/ deficiencies pointed out by the inspecting authorities shall be complied with by the contractor on priority. The department shall not render any help and shall not pay any fee for NOC.
24	Sub-Clause 15.0	<p>Insurance</p> <ul style="list-style-type: none"> (a) All the contractor's employees drawing monthly wages up to ₹21,000/- or as applicable as per the enhanced limit, shall have to be covered under ESI. The Contractor shall take insurance policy as specified in the Employee's Compensation Act only for those employees who are not covered by ESI. (b) The contractor shall insure against liability to third parties in the joint name of the Employer and the contractor for any loss, damage, death or injury which may occur to any physical property (except things insured otherwise) or any person (except person insured by employer, staff of

Design, engineering, manufacture, supply, Installation, testing and commissioning of, 630KVA, 33KV/415V Compact Substation, Cabling and other accessories to be installed, its Integration with Existing NMRC SCADA at NMRC station KP-II, Pari Chowk.

SCC Clause	Reference to GCC Sub-Clause No.	Description
		<p>other contractor working in the premises, contractor's staff under sub clause above which may arise out of the performance of the contract. The insurance shall be at least for the amount of INR 7,50,000/- for each incident.</p> <p>(c) Insurance cover for Contractor's All Risk shall be full value of Contract price.</p>
25	Sub-Clause 18.1	<p>Notices and Instructions</p> <p>The Contractor shall furnish to the Employer/Engineer the postal address of his office at Delhi NCR. Any notice or instructions to be given to the Contractor under the terms of the contract shall be deemed to have been served on him if it has been delivered to his authorized agent or representative at site or if it has been sent by registered post to the office, or to the address of the firm last furnished by the Contractor.</p> <p>The Contractor shall establish an office in the Delhi NCR in consultation with the in charge for planning, co-ordination and monitoring the progress of the Work and intimate the same in writing to in charge. In addition, the Contractor may set up field offices at convenient and approved locations for co-ordination and for monitoring the progress of fieldwork at his own cost.</p>
	Additional	<p>GENERAL CONDITIONS OF CONTRACT</p> <p>a. This contract will be governed by NMRC's General Conditions of Contract and Special Conditions of Contract. The later will have priority over the earlier one in case of any ambiguity in any of the clause.</p> <p>b. All conditions mentioned in the General Conditions of Contract (GCC) will be applicable in addition to above.</p>

Design, engineering, manufacture, supply, Installation, testing and commissioning of, 630KVA, 33KV/415V Compact Substation, Cabling and other accessories to be installed, its Integration with Existing NMRC SCADA at NMRC stations KP-II,Pari Chowk.

6. Section 6: Codes & standards

TECHNICAL SPECIFICATION OF 630KVA, 33kV/415V Compact Substation

1. Intent of specification

This specification is intended to cover Design, engineering, manufacture, supply, installation, testing & commissioning of Fully Type tested as per relevant standard, Outdoor, Plinth Mounted, Compact Substation of 33KV/415 Volts, equipped with dry type 630 KVA Cast Resin Transformer 3 way 33 KV Ring Main Unit consisting of 3 Nos. 33 KV SF6 Insulated Vacuum Circuit Breaker for 630KVA CSS, HT Metering in transformer feeder (CT,PT & Energy Meter as per PVVNL specifications),RTU/RIO & with LT Air Circuit Breaker, MCCB ,LT metering arrangement, as secondary side complete as per standard & technical data sheet.

It includes Design, Engineering, supply, installation, testing & Commissioning of Cable Differential Relay, Clean agent based Gas flooding system, Auxiliary AC/DC supply, Compact substation Protection grading with existing NMRC ring network, Castel Key arrangement & any other component or material required to make the installation complete & operable.

2. Codes & standards:

All equipments and material shall be designed manufactured and tested in accordance with the latest applicable IEC standards. The 33KV package substation Design must be as per IEC 62271-202.

All equipment and material shall be designed manufactured and tested in accordance with the latest applicable IEC standards.

The Package Sub-station offered shall in general comply with the latest issues including amendments of the following standards.

Title	Standards
High Voltage Low Voltage Pre-Fabricated Substation	IEC:62271-202
Metal Enclosed High Voltage Switchgear	IEC 62271-200
High Voltage Switchgear	IEC 62271-100,101
Low Voltage Switchgear and Control gear	IEC 60947-1
Transformers	IEC 60076
Common specifications for high-voltage switchgear and control gear standards	IEC 60694
A.C metal-enclosed switchgear and control gear for rated voltages above 1KV and up to and including 72KV and the IEC Codes herein referred	IEC 60298/ IEC 62271-200
Alternating current disconnections (isolators) and earthing switches	IEC 60129/ IEC 62271-102
Classification of degrees of protection provided by enclosures	IEC 60529
High-voltage switches-Part 1: Switches for rated voltages above 1kV and less than 52 kV	IEC 60265
Circuit breakers	IEC 60056
High-voltage alternating current switch-fuse combinations	IEC 60420
Current transformers	IEC 60185
Voltage transformers	IEC 60186
Electrical relays	IEC 60255

The design of the switchgear should be based on safety to personnel and equipment during operation and maintenance, reliability of service, ease of maintenance, mechanical protection of equipment, interchangeability of equipment and ready addition of future loads.

Design, engineering, manufacture, supply, Installation, testing and commissioning of, 630KVA, 33KV/415V Compact Substation, Cabling and other accessories to be installed, its Integration with Existing NMRC SCADA at NMRC stations KP-II,Pari Chowk.

6.1 Section 6: Package substation part details

Supply of 2 nos. 630KVA 33kV, Package Substation with following equipment details part of each Package substation.

S. No	Description
i)	<p>33kV 3 Way RMU: Quantity: 2 nos.</p> <ul style="list-style-type: none"> • Three way 33kV Non-Extensible Ring Main Unit Compact switchgear consisting of 630A SF6 insulated 3nos. of Fixed motorized SF6 insulated Vacuum circuit breaker with isolators. SF6 insulated Vacuum circuit breakers with relay having Transformer protection, overcurrent and earth fault protection & cable differential protection for ring Vacuum circuit breakers. HT metering arrangement in Transformer feeder with CT, PT & Energy Meter as per the specification of PVVNL. • Interconnection between RMU and transformer shall be by using suitable Copper un-armoured 33KV (UE) 1CX1RX95 or Aluminum armoured 33KV (UE) 1CX1RX120 sq.mm per phase cable. • Mechanical ON/OFF indicator, trip coil, Manual Close & Trip PB, live cable indicator, mechanical interlocks, padlocking facility, SF6 gas manometer with alarm & trip contact and compatible with SCADA, cable boots, CTs & PTs.
ii)	<p>Cable Box: The VCB shall be provided with suitable and identical cable boxes in front of connection 1 run of suitable cable size as per electrical safety cable from vertically below. The cable boxes shall be so located at convenient height to facilitate easy cable jointing work. The height available for Cable termination should be minimum 500 mm. The Cable termination shall be done by Heat shrinkable termination method so adequate clearances shall be maintained between phases for Termination.</p>
iii)	<p>LV Section Air Circuit Breaker: Quantity: 2 nos.</p> <p>1250Amps., 415V, 50kA,4P with 100% neutral electrically operated draw out type, ACB complete with safety shutters, 240V AC shunt trip coil & closing coil and having microprocessor based (EMI & EMC Certified) with Communication capability, provision for measurement of three phase current, protection against long time, short time, earth fault (all with adjustable time delays), instantaneous, zone selective interlocking unit for total discrimination, Communication Options to remotely read and set parameters for the protections functions, Transmission of a meter measurements, Signaling of the cause of alarm & tripping, maximeter reset etc ,6NO+6NC contacts for interlock & indications,1 no. of CT in the neutral to connect with the trip unit along with following items:</p> <ul style="list-style-type: none"> 1Nos. Motor wound spring closing mechanism 1Nos. Microprocessor release PR122 (EMI & EMC Certified) for over current, earth fault & short circuit protection, instantaneous fault. 3Nos. CT's for APFCR relay 1Nos. Under voltage Release Castle Lock & Key arrangement on Panel SCADA integration incorporating signals

Design, engineering, manufacture, supply, Installation, testing and commissioning of, 630KVA, 33KV/415V Compact Substation, Cabling and other accessories to be installed, its Integration with Existing NMRC SCADA at NMRC stations KP-II,Pari Chowk.

	<p>MCCB Quantity: 400 A (2 Nos.), 200 A (4 Nos.). 400 A/200 A,4P,35kA Moulded case circuit Breaker with Microprocessor based O/C & S/C Release with Following Accessories:-</p> <ul style="list-style-type: none"> i) Spreader Link ii) Phase Barrier iii) Aux. Switch with 1C/O iv) Extended Rotary Operating Handle v) Indication Light LED Type (230V AC) vi) RED vii) Miniature Circuit Breaker (6A,SP (10kA)) <p>Digital Multifunction Meter A,V,KW,KWH,PF,TOD, MDI</p> <p>Indicating Lamps R, Y, B, ON, OFF, TRIP LED</p> <p>Control MCB, 6A, As required</p> <p>Thermal protection relay Winding Temperature Indicator with alarm and trip contact & compatible with SCADA</p>
--	--

i.	<p>Suitable heater arrangement Aluminium PVC sleeved Bus bar from transformer Secondary to LT Section (100% for phase & 100% for N, Current density - 1A/ sq. mm)</p>
ii.	<p>Outgoing ACBs of LT Switchgear should be suitable for termination of as per standard aluminum XLPE armoured Cable.</p>
iii.	<p>Transformer section 630KVA, 33/0.415KV DYn11 Cast resin dry type transformer with Off circuit tap link and rest as per technical data sheet.</p>
iv	<p>Enclosure: Quantity:2 No. Outdoor type enclosure having modular construction of Galvanized Sheet Steel. The degree of protection for HT & LT switchgear compartment shall be IP 55 & degree of protection of transformer compartment of the enclosure shall be minimum IP23. Painting of the enclosure exterior shall be suitable for Delhi NCR region. Each compartment will be provided with the door and pad locking arrangement. The Compartment illumination lamp with door-operated switch shall be provided for each compartment. Structure of the substation shall be able to withstand the gross weight of all equipment & As per IEC 62271-202 & K10 Class It should be possible to transport the equipment along with transformer, RMU & LT Panel from one site to another.</p>
v	<p>Interconnection between HT switchgear & Transformer using XLPE cable & Interconnection between Transformer & LT switchgear using high conductivity Aluminium busbars (E91E) . Internal earthing connections by GI strips.</p>

Design, engineering, manufacture, supply, Installation, testing and commissioning of, 630KVA, 33KV/415V Compact Substation, Cabling and other accessories to be installed, its Integration with Existing NMRC SCADA at NMRC stations KP-II,Pari Chowk.

vi	DC supply for CSS shall be through in built power pack. Separate DC supply shall not be provided for auxiliary power requirement purpose.
	CSS must be SCADA compatible
	Earthing arrangement Busbar Aluminium size 50 x 6 sq. mm
	The works also includes Auxiliary Simulation Study of Existing 33 KV NMRC Aqua line for selection of network Bus 1/Bus 2 required for Loop in loop out arrangement for new CSS at KP-II & PC.

6.1.1 Design Criteria of CSS

The prefabricated-package substation shall be designed for

- a) Compactness,
- b) fast installation,
- c) maintenance free operation,
- d) Safety for worker/operator & public.

The Switchgear and component thereof shall be capable of withstanding the mechanical and thermal stresses of short circuit listed in ratings and requirements clause without any damage or deterioration of the materials.

For continuous operation at specified ratings temperature rise of the various switchgear components shall be limited to permissible values stipulated in the relevant standard and / or this specification.

6.1.2 Service Conditions:

The Package substation shall be suitable for continuous operation under the basic service conditions indicated below:

Ambient Temperature: 50 Deg C

Relative Humidity: upto 95%

Altitude of Installation upto: 200m

The Enclosure of High Voltage switchgear-control gear, Low Voltage switchgear-control gear & Transformer of the package substation shall be designed for use at Delhi NCR region. The enclosure should take minimum space for the installation including the space required for approaching various doors & equipment inside.

6.1.3 Design requirement of 33kV CSS & 33kV RMU

The main components of a prefabricated package substation are Transformer, High- voltage switch gear-control gear, Low-voltage switchgear-control gear and corresponding interconnections (cable, flexible bus bars) & auxiliary equipment and 33kV RMU. The components shall be enclosed, by either common enclosure or by an assembly of enclosure. All the components shall comply with their relevant IEC standards.

6.1.4 Outdoor enclosure:

The enclosure shall be made of 2.0mm thickness galvanized Sheet Steel tropicalized to local weather conditions including all partition sheets and doors. The outdoor enclosure wall of the CSS is designed in a corrugated wall type design for robust construction and heat dissipation. The base of enclosure shall be 4mm thick Hot dip Galvanized sheet steel.

- The metal base shall ensure rigidity for easy transport & installation.

Design, engineering, manufacture, supply, Installation, testing and commissioning of, 630KVA, 33KV/415V Compact Substation, Cabling and other accessories to be installed, its Integration with Existing NMRC SCADA at NMRC stations KP-II,Pari Chowk.

- The protection degree of the Enclosure shall be IP55 for LT & HT switchgear compartment & IP23 for Transformer compartment. Proper / adequate ventilation aperture shall be provided for natural ventilation by way of Louvers etc.IP 55 for 33kV RMU.
- The doors shall be provided with proper interlocking arrangement for safety of operator.
- The H.V. & L.V. outgoing of the transformer are to be connected to Vacuum Circuit Breaker of 33kV RMU & incomer of the Low Voltage Switchgear by means of Cables /Busbars & LT side (Busbar).

6.1.5 Internal Fault:

Failure within the package substation due either to a defect, an exceptional service condition or mal-operation may initiate an internal arc. Such an event may lead to the risk of injury, if persons are present. It is desirable that the highest practicable degree of protection to persons shall be provided. The Design shall be tested for IAC-20kA for 1 Sec AB as per IEC 62271-202. Type test report of arcing due to internal fault of the offered type of RMU inside CSS should be submitted with offer.

6.1.6 Covers & Doors:

Covers & doors are part of the enclosure. When they are closed, they shall provide the degree of protection specified for the enclosure. Ventilation openings shall be so arranged or shielded that same degree of protection as specified for enclosure is obtained. Additional wire mesh may be used with proper Danger board for safety of the operator. All covers, doors or roof shall be provided with locking facility or it shall not be possible to open or remove them before doors used for normal operation have been opened. The doors shall open outward at an angle of at least 90° & be equipped with a device able to maintain them in an open position.

6.1.7 Earthing:

All metallic components shall be earthed to a common earthing point. It shall be terminated by an adequate terminal intended for connection to the earth system of the installation, by way of flexible jumpers/strips & Lug arrangement. The continuity of the earth system shall be ensured taking into account the thermal & mechanical stresses caused by the current it may have to carry. The components to be connected to the earth system shall include:

- a. The enclosure of Package substation.
- b. The enclosure of High voltage switchgear & control gear from the terminal provided for the purpose.
- c. The metal screen & the high voltage cable earth conductor.
- d. The transformer tank or metal frame of transformer.
- e. The frame &/or enclosure of low voltage switchgear.

There shall be an arrangement for internal lighting activated by associated switch for HV, Trans-former & LV compartments separately.

6.1.8 Labels:

Labels for warning, manufacturer's operating instructions etc. shall be durable & clearly legible.

6.1.9 Cleaning & Painting:

The paints shall be carefully selected to withstand sea shore conditions. The paint shall not scale off or crinkle or be removed by abrasion due to normal handling.

6.1.10 General Finish:

Totally enclosed, metal clad, vermin and dust proof suitable for tropical climate use as detailed in the specification.

Shed to access LT & HT Panel in raining Season should also be provisioned.

Design, engineering, manufacture, supply, Installation, testing and commissioning of, 630KVA, 33KV/415V Compact Substation, Cabling and other accessories to be installed, its Integration with Existing NMRC SCADA at NMRC stations KP-II,Pari Chowk.

6.1.11 Ratings:

The busbars shall have continuous rating with relevant IEC standard.

6.1.12 Breaking & Making Capacity:

Circuit Breaker shall be capable of having rupturing capacity of 50kA symmetrical at 33KV.

6.1.13 Busbars:

Switchgear shall be complete with all connections, busbars etc. The continuous rating of copper busbars shall be fully encapsulated by SF6 gas inside the steel tank. Busbar should be rated to withstand dynamic and thermal stresses for full length of switchgear.

6.1.14 Earth Switch:

Earth switch should be rated equal to switchgear rating. Earth switch should be quick make type capable of making rated fault current. Earth switch should be operated from front of the cubicle.

6.1.15 The Mechanism:

All the mechanism should be situated in the mechanism compartment behind the front covers outside SF6 tank. Mechanism for switch and earth switch is operating both the switches via one common shaft.

6.1.16 Front covers:

Front covers contains the mimic diagram of the main circuit with the position indicator for the switching devices. The voltage indicator should be situated in front covers. Access to the cable bushing in the lower part of each module.

6.1.17 Position Indicator:

Position indicator are visible through the front covers and are directly linked the operating shafts of switch devices.

6.1.18 Voltage indicator:

Voltage indicator situated in front covers, one of each module and indicate the voltage condition of each incoming cable. Identification of phase is achieved through labels L1, L2, and L3 on the front of the voltage indicator. Voltage indicator should comply requirement of IEC61243.

6.1.19 Cable Compartment:

It should be possible terminate the cables as specified in the specification. The access to the compartment shall be possible by removing the cable cover and bolted to the main frame. Removable steel covers close the cable compartment. Arc proof cable covers should be available. Each module should have separate compartment that is segregated from each other by means of partition wall. A partition wall should be fitted to divide the cable compartment from the rear side of the switchgear. In case arc in- side the tank, followed by opening of pressure relief device the partition wall prevents the hot gases flowing out from the pressure relief to enter the cable compartment.

6.1.20 Power Connection:

The cable is installed in the dedicated compartment below the mimic front cover. In each compartment the earthing bar should be fitted with 4 screws M10.

6.1.21 Fault passage Indicator:

Each RMU should be equipped with display the phase current of feeder circuit. Each RMU should be provided with fault passage indicator to on isolator to indicate earth fault. This facilitates quick detection

Design, engineering, manufacture, supply, Installation, testing and commissioning of, 630KVA, 33KV/415V Compact Substation, Cabling and other accessories to be installed, its Integration with Existing NMRC SCADA at NMRC stations KP-II,Pari Chowk.

of fault section of line. This unit shall be self-contained required no auxiliary power and shall be integral part of RMU to avoid thefts. The fault shall be displayed by LED/flag indication with three options for reset. (Manual/on restoration of supply/Settable time

6.1.22 Switchgear:

The SF6 RMU shall be sealed for life, the enclosure shall meet the “sealed pressure system”. There shall be no requirement to ‘top up’ the SF6 gas. It shall provide full insulation, making the switchgear insensitive to the environment. Thus assembled, the active parts of the switchgear unit shall be maintenance free.

The switchgear & switchboard shall be designed so that the position of different devices is visible to the operator on the front of the switchboard & operations are visible as well. The switchboard shall be designed so as to prevent access to all live parts during operation without the use of tools.

RMU should be tested for internal arc fault test.

6.1.23 Vacuum Circuit Breaker:

The Unit shall consist 630A Tee-off spring assisted three positions, three pole circuit breaker, with integral fault making / dead breaking earth switch. The function shall be naturally interlocked to prevent the main & earth switch from being switched ‘ON’ at the same time & the CB not allowed to trip in ‘Earth On’ position. The selection of the main/earth switch lever on the panel, which is allowed to move only if the main or earth switches in the off position. The lever shall be able to pad locked in either the main or earth position.

The manual operation of the circuit breaker shall not have an effect on the trip spring. This should only be discharged under a fault (electrical) trip condition; the following manual reset operation should recharge the trip spring & reset the CB mechanism in ‘main off’ position.

6.1.24 Protection Relay:

The purpose of the protection equipment is to ensure insulation or de-energizing of equipment whose operating conditions have become abnormal to avoid:

- any major repercussions on the traffic.
- any damages or dangerous effects on person and equipment.

6.2 Performances required

The protection system shall deploy numerical relays and shall comply with a high performance standard regarding:

Reliability

This criterion defines the mean time between failures (MTBF), which has to be calculated for about 10 years.

Maintainability

This criterion represents the mean time for repairing (MTTR) and has to be considered only by replacement of faulty function or sub assembly.

The MTTR does not exceed 2 hours not including the dead time to reach the site.

Availability

This is expressed in terms of ratio using the formula: $(MTBF/MTBF+MTTR)\%$ and has to represent a level of 99.95 %.

Safety of operation

Design, engineering, manufacture, supply, Installation, testing and commissioning of, 630KVA, 33KV/415V Compact Substation, Cabling and other accessories to be installed, its Integration with Existing NMRC SCADA at NMRC stations KP-II, Pari Chowk.

Safety is ensured by the means of Cyclic self-test ensuring general supervision on software of equipments. In case of fault, a watchdog is activated. All of inputs are insulated in galvanic and capacitive view and complemented.

Electro-magnetic compatibility

Due to the consequent interference levels in the premises, protection equipment has to present sufficient level of immunity defined by the following standards:

- IEC 61000.4-2 Class 3,
- IEC 61000.4-4 Class 4,
- IEC 61000.4-5 Class 3.

Such criteria shall be obtained by using either digital type relays or specific PLC cards. Refer clause 9 for detail description.

6.3 Protection descriptions

A distinction shall be made between the following cases

Hydraulic or thermal protections

These protections, such as lack of pressure or abnormal temperature, shall include measuring elements situated on the protected apparatus, actuating contact (mandatory of flip-flop type) which represent the start of the protection line.

Electrical protections

All the protection relays used shall be of numerical Type

a. Protections through lack of monitoring voltage

Each cut-out apparatus shall include a device controlling its opening and preventing it from any reclosing in case of lack of monitoring voltage.

b. Protections through lack of AC voltage

Ensured by means of phase - phase voltage measurements with threshold, possibly associated to time delay, adjustable as well. The measurement shall be supplied from the secondary of the voltage transformers.

c. Protection against phase-phase short-circuits

Ensured by means of current relays (primary current measurement relays with adjustable threshold, associated to time delay also with adjustable threshold). The current relay shall be supplied from the secondary of the current transformers.

d. Over current protections

This function ensures the tripping of concerned circuit breaker when the current value reach the highest allowable load on the network in instantaneous or delayed time conditions.

Following the network configuration, pre-set tripping thresholds could be commuted via automatic interlocking or voluntary action.

e. Tripping curves characteristics could be:

- At Constant time,
- At dependent time following characteristic:
- Inverse,
- Very inverse
- Extremely inverse.

f. Protection against zero sequence faults

At the output level, these shall be ensured by means of zero sequence current measuring relays (obtained through associating of the currents from the current transformer). These relays shall not be affected by the capacitive currents in the cables during unbalanced operative times which occur on the power supply (such as earthing fault of the other cables, etc.).

Design, engineering, manufacture, supply, Installation, testing and commissioning of, 630KVA, 33KV/415V Compact Substation, Cabling and other accessories to be installed, its Integration with Existing NMRC SCADA at NMRC stations KP-II, Pari Chowk.

Differential protections

Based on the instantaneous comparison, for each phase between the bar set or transformer incoming current and outgoing current, through current transformers.

g. Initial alarm threshold

- Performance of the CB is unaffected; in particular breaking capabilities remain intact.
- Immediate intervention by specialist is not necessary.

h. Second alarm threshold

- CB tripping and locked until SF6 refilling
- Isolating capabilities of the CB remain intact
- Immediate intervention by specialist is necessary.
- Control orders are inactive.

Devices

The devices used must provide full reliability and operating safety and not represent a weak spot for the tightness of equipment.

At no time shall these devices indicate any wrong data, not lose their accuracy regardless of ambient temperature or of the operating incident concerned.

This is why monitoring devices with temperature compensation are specified.

Gas compartment should have its own SF6 pressure monitoring facilities as well as its static filters as per the requirement.

Pressure relief devices should be designed to limit maximum pressure rise below the bursting level of the enclosure and barrier insulation but not designed to retain the fragment of bursting disk.

All gas compartments shall be equipped with rupture diaphragms to prevent the enclosure from uncontrolled bursting.

Presence of voltage

Voltage relay shall be used to authorize the operation of the incoming isolators and earthing isolators on no load.

6.4 Staging of protections

Selectivity of protection arrangements shall be provided so as to avoid all unwanted tripping.

The time delay of the various circuit breakers shall be set so as to ensure chronological selectivity of the tripping.

The supplier shall define precisely the minimum intervals between the various protection stages, accounting for the timings and for the actuation times of each one of the apparatus involved.

To avoid unwanted tripping, it shall be necessary, in particular, to account for transient phenomenon such as energizing of transformers and engagement of cables,

33 kv cable protection

A fault on the 33 kV cables in the 33 kV Distribution Loop, will be cleared by the Circuit Breaker (RCCBIMCCB) located in the AMS & CSS, wherefrom the Loop is deriving 33 kV power supply. Pilot wire based relay/differential protection shall also be provided for all 33 kV cables running in elevated section between any ASS & CSS. In case of fault in a section protected by pilot wire based differential relay, the CBs at both ends of the section shall be tripped to isolate the faulty section. Over current & earth fault protections shall also be provided in each cut-off / ring main CB as backup protection. All protection including CTs as required will be provided by Contractor.

Design, engineering, manufacture, supply, Installation, testing and commissioning of, 630KVA, 33KV/415V Compact Substation, Cabling and other accessories to be installed, its Integration with Existing NMRC SCADA at NMRC stations KP-II,Pari Chowk.

Over current & earth fault protection (including CTs, relays) shall be provided by Contractor.

6.5 CSS equipment protection

Medium voltage network protection

The medium voltage network will be protected by RCCB/MCCB's located at CSS. Nevertheless Pilot wire relay protection shall be provided as explained above.

Transformer protection

The transformer is protected against fault by the followings:

- F 50: Instantaneous over current protection
- F 51: Time delayed over current protection
- F50 N: Instantaneous earth fault protection (zero sequence)
- F51 N: Time delayed earth fault protection (zero sequence)

The functioning of these protections shall trip the MVCB. Moreover, it shall be protected against heating by a two threshold temperature protection.

The first threshold shall transmit an alarm to the CSS as well as in the OCC/BCC. The second threshold shall trip the respective MVCB and corresponding downstream VCB and transmit an alarm to the OCC/BCC.

6.5.1 Locking Arrangement:

- Suitable padlocking arrangements shall be provided as stated below.
- CB manual operating handle in the "OFF" position.
- Each feeder Panel operating handle in 'Closed' 'Open" or 'Earth' position.
- Locking arrangement of CSS cubical as per direction of E/I.

6.6 Low voltage switchgear

1. ACB should be mechanically robust of compact design, air break horizontal and withdraw able type, confirming to IS/IEC 60947-2 and EN 60947-2.
2. Manual charging as well as by 240 V AC motor with charged spring closing mechanism complete with anti-pumping relay, discharge resistor, auxiliary switch, etc.
3. 240 V A.C shunt-trip coil shall be operable, within operational voltage range of 70% to 110% of rated voltage as per Clause 7.2.1.3 of IEC 60947-1.
4. The operating mechanism shall be trip-free.
5. Maximum number of circuit breaker auxiliary switches, spare auxiliary switches to be equally divided between normally open and normally closed. At least 4 spare pairs of N.O. and N.C. volt free contacts shall be provided.
6. Indicating lamps for on, off, tripped on fault and trip supply healthy with all necessary push buttons, panel wiring, bus wiring, terminals, fuses, etc.
7. Power and control cable terminals with undrilled gland plates for outgoing power cables and multi-core cables.
8. Electrical connection between the breaker and switchboard shall be of plug and socket type with automatic screening shutters. An interlock to prevent withdrawal when the breaker is closed.
9. Number of Poles shall be as per BOQ.
10. Local/auto control selector switch shall be lockable in all positions. The automatic control shall be defeated when the selector switch is put at local or OFF position as per drawing and BOQ

Design, engineering, manufacture, supply, Installation, testing and commissioning of, 630KVA, 33KV/415V Compact Substation, Cabling and other accessories to be installed, its Integration with Existing NMRC SCADA at NMRC stations KP-II, Pari Chowk.

11. Remote indication and alarm facilities shall be provided for Circuit-breaker open, Circuit-breaker closed, Circuit Breaker is ready to close, Circuit-breaker tripped on fault, and Switch position of local/remote control selector switch.

6.7 Control switch for air circuit breakers:

Control switch for air circuit breakers shall be as follows:

- Air Circuit breakers shall be fitted with operative switches of the pistol grip type. The handles of control switches for air circuit breakers shall turn clockwise for closing and anti - clockwise for tripping.
- The control switch shall be clearly labelled as CIRCUIT BREAKER OPEN - NEUTRAL - CLOSE, with spring return to the neutral position. Mechanical interlock shall be fitted to prevent repetitive closing without moving first to the trip position, and shall be capable of padlocking in the neutral or trip position.

Set of terminals wired to provide for connection to the following:

- Operation of emergency push button as per requirement or as per BOQ.
- Signal cables wired to terminal block for remote monitoring to SCADA.

Electrical Characteristics:

- Rated Insulation Voltage: 1000 V
- Rated Frequency: 50 Hz
- Rated ambient temperature: As per Clause 6.1.1 and 6.1.3 of IEC 60947
- Utilization category: B or as per drawing or BOQ.

Rated uninterrupted current:

as mentioned in BOQ, however the contractor must provide breaker after taking into account of the installation conditions and derating for ambient temperature, based on selected make during preparation of working drawings.

Current Ratings shall be as follows:

- Rated short-time withstand current (I_{cw}): 70/65/50 kA for 1 second (minimum)
- Rated ultimate short circuit breaking capacity (I_{cu}): 70/65/50 kA based on actual fault level or as per BOQ.
- Rated service short-circuits breaking capacity (I_{cs}): 100% of I_{cu}, and Rated short-circuit making capacity: shall be at least 2.1 times of ultimate short circuit breaking capacity at 0.25 power factor or as per BOQ.

Protection:

ACB shall have microprocessor based protection releases for type of faults with selective over current (long time, short time & instantaneous) & earth fault protection, measurement of electrical parameters and with communication capability with SCADA/BMS system. Any other additional protection as mentioned in BOQ. ACB shall have an LED/LCD display to show true RMS current in all the three phases and highest current among these phases. The release shall be equipped with self-diagnostic feature with indication. The release shall have zone selective interlocking and be capable through Modbus over Serial (RS 485 port) communication where applicable. The overload and short circuit characteristics should be front adjustable and password protected or suitable arrangement to prevent unauthorized entry with the approval of Engineer.

Design, engineering, manufacture, supply, Installation, testing and commissioning of, 630KVA, 33KV/415V Compact Substation, Cabling and other accessories to be installed, its Integration with Existing NMRC SCADA at NMRC stations KP-II,Pari Chowk.

- 1) **The bidder shall submit the LSIG settings of ACBs in accordance with the 33kV Circuit breaker so as to achieve complete discrimination.**
- 2) The release should have an internal fault indication for faster fault diagnosis/self-diagnostic feature is required.
- 3) The release should have fault indications by which discrimination of fault is possible.
- 4) Fire resistant transparent covers shall be provided over ACB's to achieve IP-54 protection and door interlock so that ACB access door shall not open if ACB is ON otherwise it will automatically OFF if Door is opened.

6.8 ACB controlled & monitored and interlocks.

ACBs shall be SCADA controlled and monitored with following signals

- i) Local/Remote mode status
- ii) SCADA permissive indication
- iii) CB in Test/service
- iv) CB Spring Status
- v) Trip relay operated
- vi) Switching state (Open)
- vii) Switching state (Close)
- viii) CB under voltage trip relay operated
- ix) CB open Command
- x) CB close command
- xi) SCADA permissive command

6.8.1 Interlocks and Test Operation Facilities

All ACBs shall be provided with interlocks to ensure that:

- 1) The ACB cannot be plugged in or isolated while it is closed,
- 2) The ACB cannot be closed until it is fully plugged in or completely isolated
- 3) The ACB cannot be closed in the service position without completing the auxiliary circuits between the fixed and moving portions
- 4) With manual charged and motor charged spring mechanisms the springs cannot be discharged until they have been fully charged and until the means for charging has been removed or disconnected,
- 5) Facilities shall be provided for testing the ACB operation when in the isolated and withdrawn positions by the normal means as in service, and
- 6) Where control circuits are provided and interlock circuits are broken via plugs on withdrawal of the ACB, a minimum of one jumper lead and plug assembly of each size and type shall be provided to facilitate testing in the withdrawn position.
- 7) The neutral shall be rated for 100%

6.8.2 Safety Shutters

- 1) A set of shutters with padlocking facilities shall be provided to cover each three phase group of stationary isolating contacts. The shutters shall be independent and operated automatically by a positive drive from the ACB withdrawal mechanism
- 2) In order to prevent unauthorized operation, the withdraw able air circuit breakers shall be provided with padlock facilities to secure them in their connected, test and isolated positions.

Design, engineering, manufacture, supply, Installation, testing and commissioning of, 630KVA, 33KV/415V Compact Substation, Cabling and other accessories to be installed, its Integration with Existing NMRC SCADA at NMRC stations KP-II,Pari Chowk.

6.8.3 Discrimination

Selection of ACB, MCCB and MCB shall be of same make. Total discrimination up to the design fault level must be available between the various elements of switchgear (ACB, MCCB, MCB etc) selected. Supplier must provide test certificates from acceptable, accredited and reputed laboratories or submit published discrimination charts/tables to prove the same. In view of Standardization and Uniformity, mixing of two series of switchgear (even from the same manufacturer) for either MCCB or ACB will not be permitted.

In case higher frame sizes rating of switchgear(than those specified In the BOQ) is required to be provided to achieve the above requirement, due to selection of a particular make, the same shall be provided at no extra cost if other makes are able to achieve the same with the specified frame size.

6.8.4 Auxiliary switches and contacts

Auxiliary switches provided for indication, protection, metering, control, interlocking supervisory purposes shall be readily accessible at the front of the Electrical Panels. Adequate secondary contacts shall be included to enable the auxiliary switch to be wired to the fixed portion of the equipment.

For each control compartment, spare auxiliary contacts with a minimum of two NO and two NC contacts shall be provided and wired to suitably identify spare terminals.

Auxiliary contacts for all applications shall be rated at 240 V AC with contact rating of at least 6 A AC and operating life of at least one million on on-load operations at 0.4 power factor inductive load.

7. Cables Standards, Laying and Other guidelines

The 33 kV Cables shall conform to IEC 60502 and shall be of 18130 kV (36kV).The cables shall be of dry-insulated, radial-field cables, based on proven technology. They shall be constituted by assembly of three single core cables in twisted or clover leaf pattern, annealed circular stranded copper conductor or Stranded A1 Conductor for the cables as specified. The cable shall be XLPE insulated with semi-conducting screen over conducting core. The cable shall also be Tape armoured. It shall conform to IEC-60502Part 2 latest for construction and for testing.

7.1.1 Standards

The 33 kV Cables shall satisfy the following requirements and shall also comply with standards in force when the cables are manufactured, particularly which are in the following table (Unless otherwise stipulated in the specifications, the latest version of the following) Standards shall be applicable:-

Standard#	Description
IEC 60502	Power cables with extruded insulation and their accessories for rated voltages from 1 kV (Um = 1,2 kV) up to 30 kV (Um = 36 kV) - Part 2: Cables for rated voltages form 6 kV (Um = 7,2 kV) up to 30 kV (Um = 36 kV)"
IEC 60288	Conductors of insulated cables
IEC 60840	Power cables with extruded insulation and their accessories for rated voltages above 30 kV (Um = 36 kV) up to 150 kV (Um = 170 kV) -Test methods and requirements
IEC 60332	Part 1 : Test on electric and optical fibre cable sunder fire conditions Part 2 : Test on electric cables under fire condition
IEC 608 11	Electric and optical fibre cables-Test methods for non-metallic materials

Design, engineering, manufacture, supply, Installation, testing and commissioning of, 630KVA, 33KV/415V Compact Substation, Cabling and other accessories to be installed, its Integration with Existing NMRC SCADA at NMRC stations KP-II,Pari Chowk.

IEC 60754	Test on gases evolved during combustion of materials from cables - Part 1: Determination of the halogen acid gas content
ASTM D 2843	Standard Test Method for Density of smoke from the Burning or Decomposition of Plastics
ASTM D 2863	Test Method for measuring of Minimum Oxygen Concentration to support candle- Like Combustion of Plastic (Oxygen Index)
IS 7098 Part -2	Cross linked polyethylene insulated thermoplastic sheathed cables, Part 2 :for working voltages from 3.3 kV up to &including 33 kV.

7.1.2 Technical Requirement

The cables shall be insulated with chemically cross-linked polyethylene (XLPE), with semi-conducting screen over a copper conducting core, insulating envelope Aluminium Tape armouring and suitable protective sheath.

Operating voltage: 33 kV rms between phases,

Specified voltage: 18/30 kV rms (according to IEC 60502)

-Conductors as specified -- -

The Cable shall conform to IEC 60402 or equivalent. The cables, in addition, shall be non-fire propagating, non-toxic and low-smoke producing type. The Various constructional features required for the 33 kV cables are as under:

➤ Conducting Core

The conducting core shall be made of bare annealed copper or aluminium, as the case may be according to class 2 as per publication IEC 60228; Latest Version

➤ Conductor:

The conductor shall be formed from annealed circular stranded Copper (or stranded Aluminium conductor as the case may be) complied with IEC latest publications 60228. The conductor shall be compact circular stranded.

➤ Conductor Screen:

The conductor screen shall be provided as per clause 7.1 IEC 60502-2:2005 or equivalent clause in latest version of IEC 60502-2. The conductor screen shall consist of suitable thickness and volume resistivity. It shall be easily removable from conductor during jointing. Nominal thickness of conductor screen shall be 0.7mm.

➤ Insulation:

The insulation shall be XLPE complying with IEC 60502 and IEC 60811. The insulation shall have a higher degree of Cross-Linking, free from contaminants and air voids, heat resistant and shall be applied by the extrusion process. The XLPE insulation shall be suitable for use on power cable in wet and dry locations at conductor temperature as per IEC 60502-2. For this purpose, short circuit current in conductor is to be considered as 7kA. The conductor with screening shall be provided with cross linked polyethylene (XLPE) insulation applied by extrusion. The nominal thickness of insulation shall be not be less than 8mm as per IEC 60502-2 and subject to tolerance as per IEC - 60840, clause 10.6.2. Alternatively higher thickness of insulation as per IS 7098 with specified eccentricity in IS 7098 will also be accepted.

Design, engineering, manufacture, supply, Installation, testing and commissioning of, 630KVA, 33KV/415V Compact Substation, Cabling and other accessories to be installed, its Integration with Existing NMRC SCADA at NMRC stations KP-II, Pari Chowk.

The insulation compound shall be of high quality, heat, moisture, ozone and corona resistant. XLPE compound should be from reputed manufacturer e.g Borealis, Sweden or NUC Japan or equivalent with satisfactory service experience of more than 5 years. The Insulation shall be applied by triple extrusion and vulcanized using dry curing process to form a compact

Homogenous body free from micro voids and contaminants.

➤ **Insulation Screen**

The Insulation screening shall be applied direct upon the insulation as per IEC 60502-2. The screen shall be tightly fitted to the insulation to exclude all air voids and still it could be easily stripped on site. Semiconducting compound should be from a reputed manufacturer e.g Bomlis, S m n or NUC Japan or equivalent with satisfactory service experience of more than years. Nominal thickness of insulation screen shall be 0.7 mm. The conductor screen, insulation & insulation screen shall be extruded in a single process (triple extrusion).

➤ **Water Barrier:**

➤ The water barrier shall be semi-conducting water swellable tape to be applied over the extruded insulation screening to block and prevent moisture propagation in a longitudinal direction. The semi-conducting tape shall be suitable for the operating temperature of the cable and compatible with the insulation. !

➤ **Metallic Screen:**

The metallic screen shall be plain copper round wires and copper tape applied helically over the semi-conductor bedding tape@). An annealed plain copper binder tape shall be applied in the form of an open helix, over the copper wire copper tape should be able to withstand specified earth fault current (minimum 1 kA for 3 sec). Bidder to submit the calculations giving details of the area of copper wire screen copper tape.

The three-phase short-circuit current capacity of metallic screen is to be considered, 1 kA (for the cables to be fed by substations where Neutral Grounding Resistor (NGR) is installed).

The sheath shall be impervious to moisture, reasonably close fitting and free from defects and impurities such as oxide, which give rise to failure under working conditions.

➤ **Inner Sheath:**

A polypropylene tape shall be applied over the metallic screen. For FRLSZH- cables and inner layer of FRLSZH tape shall be applied over metallic screen followed by Polyethylene laminated Aluminium tape.

➤ **i. Armouring:**

Double Tape Aluminium armouring should be applied over the inner sheath and the thickness of the same should be as per IEC 60502.

➤ **Short Circuit Rating of Metallic Sheath/Screen**

The area of copper wires copper tape shall be designed to meet the requirement of the system short circuit rating of 1 kA for 3 seconds.

➤ **Outer sheath:**

The outer sheath to be provided as per IEC 60502-2.

➤ **Additional Requirement**

Cables laid on viaduct & ramps shall be exposed to sun, therefore such cables shall be capable of withstanding ultraviolet radiation. They shall be black in colour with identification for Red, Yellow & Blue phases which can be clearly seen without efforts throughout the run.

Design, engineering, manufacture, supply, Installation, testing and commissioning of, 630KVA, 33KV/415V Compact Substation, Cabling and other accessories to be installed, its Integration with Existing NMRC SCADA at NMRC stations KP-II,Pari Chowk.

➤ **Outer Sheath should have following features:**

Cables laid in elevated sections shall be exposed to sun. The outer sheath shall be extruded in black colour with UV protection, FRLS PVC conforming to the requirement of IEC specifications and extruded continuously. Such cables shall have phase identification after interval of 10 meters. Colour coding shall be: done at manufacturer's works. The details of compound used for outer sheath shall be submitted.

➤ **The Contractor shall confirm the cross section of the cables in as regard to:**

- a) The route installation.
- b) The thermal condition in service,
- c) The climatic conditions,

The energy and currents flowing through these cables, considering the worst electrical conditions,

➤ **The protective sheath shall carry the indications listed below; in letters and digits at least 6 mm high**

Designation of ownership,
Nature and cross-sectional area of conductors,
Specified cable voltage,
Phase numbering,
Manufacturer's name,
Length of cable shall be marked at 1 m interval,
Year and month of manufacturing

The cable shall be manufactured by a company having ISO accreditation for quality

The manufacturing process of XLPE Cables shall consist of conductor screen, insulation & insulation screen which shall be extruded in a single process (Triple extrusion) and cross linked by a standard process of dry curing technology to ensure homogeneity and absence of micro voids. The cables:- shall be manufactured by "Dry Curing "Process.

The contractor shall provide trefoil clamps of non-metallic sturdy type at every 5 with cable ties at every meter. The Employer may decide to visit the works of cable manufacturer to verify the manufacturing process mentioned.

The Bidder along with the Bid, shall submit the details regarding cable construction, bill of material the manufacturing process proposed to be adopted for the manufacturing of 33 kV cables to be used in the project, along with Q control measures adopted by the Manufacturer, to ensure:-

The values and tolerances are strictly as per IEC

The cable manufacturer exercises strict quality control measures. Including stage inspections, routine inspections etc to ensure compliance to standards.

Periodical inspections of the Manufacturer works, manufacturing processes, internal Quality control records of the manufacturer etc shall be carried out by the user (NMRCI Nominated agency), to ensure compliance to Quality standards.

Design, engineering, manufacture, supply, Installation, testing and commissioning of, 630KVA, 33KV/415V Compact Substation, Cabling and other accessories to be installed, its Integration with Existing NMRC SCADA at NMRC stations KP-II,Pari Chowk.

7.1.3 Maintenance & LIFE

The cable should be designed for maintenance free service of minimum 35 years for all types of installation & under prescribed environmental conditions.

The manufacturer shall have laid down in-house selection process of the raw material used and shall submit all details, if equivalent raw material is used whenever specified.

7.1.4 Cable Test Standards

All type tests to be conducted as per IEC 60502-2. The 33 kV cable shall comply with following Test Standards in addition to test standards of IEC 60502:

- a. IEC 60332 Part 1 and 3, category A, test on single and bunched cables under fire condition.
- b. Limiting Oxygen Index at least 30 tested as per ASTM D-2863.
- c. Temperature index of minimum 250 deg C as per IS 7098 (Part-2).
- d. Smoke density Test (on sheathing material), when tested in accordance to ASTM D- 2843, maximum smoke density rating shall be 60 as per IS 7098 Part - 2. This will be applicable for FRLS cable.
- e. All Insulation is to be moisture and heat resistant, with temperature rating appropriate to the application conditions and in no case lower than 90 deg.

The user may ask repetition of the following type tests-

- Bending Test
- ~ Tan δ measurement for cables
- Impulse test followed by voltage test for 4 hrs.

The manufacturer shall not change the Bill of Material used in the manufacturing of samples for routine and Type testing as repeated above and in cables intended to supply against the contract.

Connecting Junctions –

- Connecting junctions shall reconstitute perfectly all elements of the HV cables, so as to obtain electrical and mechanical characteristics at least equal to those of the cable.
- contractor shall submit to the client for approval, a detailed description of the technique foreseen for execution of connections in HV lines.
- However, maintenance and repair being able to be carried out only during a short period of time, at night, due consideration shall be given to connection processes having the following characteristics, quality being otherwise equal:-
 - i. quickness of execution
 - ii. possibility of replacement without having to disturb the cable
 - iii. Small bulk.
 - iv. All. 33kV straight through joints shall be of Heat Shrink Type.

Design, engineering, manufacture, supply, Installation, testing and commissioning of, 630KVA, 33KV/415V Compact Substation, Cabling and other accessories to be installed, its Integration with Existing NMRC SCADA at NMRC stations KP-II,Pari Chowk.

➤ **Cable Heads**

MV cable heads shall be connected to cable junction boxes with the MV apparatus. All 33kV Cable terminations shall be Heat Shrinkable Type 'Raychem' or equivalent. For underground section straight through joint / termination shall be made by using Halogen free jointing kit.

➤ **Execution Rules**

The entire supply shall be executed according to all Rules of the Art pertaining to professional-grade equipment, and in compliance with the technical specifications and specifications of the International Electro technical Commission relative to power supply cables (IEC 60055-1, 60055-2 and 60502-1). The supply shall be delivered upon request by the client, only after execution of in-plant inspection operations and satisfactory testing according to the technical requirements imposed.

The cables shall pass all the tests stipulated in the IEC 60502 rules in force on the date of the order.

The sleeves and the insulating materials used shall meet the guarantee requirements imposed.

The equipment shall be capable of withstanding intensive use without alteration, and of performing its duty even after extended idle period.

➤ **Atmospheric and climatic conditions**

The entire equipment shall be designed for operation in hot weather, according to the climatic conditions.

The equipment shall be sturdy and properly treated against corrosion. This protection shall be suited to the various environmental conditions encountered in the various parts of the network.

It must be noted that environmental conditions shall be very severe during construction; these conditions shall not be the cause of any alteration of equipment or material whether already installed or simply stored.

➤ **Cable technical and test sheet**

The tests shall be performed according to the corresponding IS/IEC standard.

After completion of laying of the cable and its accessories, a dielectric test is carried out through application, for 15 minutes, of an alternating voltage equal to square root $3.U$ or a direct voltage equal to $4.U$.

7.1.5 Cable laying specification

➤ **General**

MV cables shall be laid all along the line on viaduct, and in ground wherever required, as per IS: 1255-1983 (with latest version).

They shall be supplied on reels, the standard of which shall be determined according to the laying conditions. This specification defines all types of work related to installation of cable routings, paying out and laying of the cables, at grade, on viaduct, in tunnels etc.

Contractor shall produce a stake-out plan at 1:500 scale, which shall indicate the precise laying position and the type of routing (in channel or inside duct), accounting for all specific location of the line (Track crossings and entry into electrical stations).

➤ **Laying in Viaduct**

Cables shall be laid in cable brackets/trenches, along the walkway. Contractor shall provide suitable means for secured cable laying on hangers/trays etc. with approval of NMRC. The supply and installation of trefoil clamps of Non - metallic sturdy material at every 5 meters with cable ties every meter in the intervening space is under the scope of this contract. 33 kV danger boards will be provided at every 100 m shall be provided and also at locations wherever cables have to cross under tracks (near sidings etc.). Wherever trefoil clamps are not feasible cable ties shall be provided as approved by NMRC.

Locations of joints shall be marked by suitable boards in tunnels, viaduct, under craft, shaft etc.

Design, engineering, manufacture, supply, Installation, testing and commissioning of, 630KVA, 33KV/415V Compact Substation, Cabling and other accessories to be installed, its Integration with Existing NMRC SCADA at NMRC stations KP-II, Pari Chowk.

➤ **Tagging**

All cables laid inside channels, or on cable-tray shall carry an 8 x 5 cm PVC tag placed every 10 m and in specific locations such as connection sleeves, entry into and exit from ducts, possible pulling chambers.

These tags, fastened via two clamps, shall bear the labels approved by the Employer.

Tagging of cables plays a part in safety as regard identification of the cables in case of incident, and shall be made very carefully and Contractor shall be responsible for any error or for any incident subsequent to such an error.

The tags shall be fastened right after the paying out of each reel.

➤ **Laying in Ground**

On all the road crossings and at other appropriate locations, cable laying shall be through trenchless drilling and cable passing through high density polyethylene (HDPE) pipes in concrete pipes of appropriate diameter and thickness.

The 33kV cable between AMS and ASS of nearby station shall be laid in ground at depth of 1.2 meter duly protection by RCC slabs.

The cable laying shall be generally in accordance with IS1255; Latest Version or latest version and manufacturer's recommendations. The laying standards for cables laid in ground shall not be less than the following: The trenches for carrying the cables shall be at least 1.3 m deep and 1.0m wide.

Cables shall be laid at 1.2 m depth below the ground level and over a 100mm bed of coarse sand.

Trench is to be filled with sand up to a depth of 0.8 m below ground level.

Warning concrete RCC slabs each approx. 0.8m x 0.25m x 0.05m (Thick) shall be laid above the sand.

Trench shall be filled with earth up to 200 mm below the ground level.

A warning net/tape printed with details of cables & NMRC's name shall be laid above the earth (at 200 mm depth below ground level).

The top space of 200 mm shall be filled suitably and given a final finish matching the surrounding.

The route shall be marked by suitable RCC cable markers at the suitable intervals and the positions of straight through joints shall be indicated by suitable RCC route markers.

Route and joint bay markers shall contain details of NMRC, cables contact nos. of NMRC (Control centre) etc.

On all the road crossings and at other appropriate locations, cable laying shall be through trenchless drilling and cable passing through high-density polyethylene (HDPE) pipes in concrete

➤ **Conduits (HDPE).->**

Whenever the cables have to be laid below roads, they shall be laid in multi conduit made of HDPE pipes embedded in concrete. The arrangement shall be generally as follow :

Each circuit of the Incoming feeder shall consist of three cables, each cable-laid in a conduit (so 6 cables laid in 6 conduits).

Conduit for each cable shall be not less than 150 mm in diameter

Design, engineering, manufacture, supply, Installation, testing and commissioning of, 630KVA, 33KV/415V Compact Substation, Cabling and other accessories to be installed, its Integration with Existing NMRC SCADA at NMRC stations KP-II,Pari Chowk.

In addition to the 6 cables in conduits as above one spare conduit (150 mm dia), without cable, shall be provided.

in addition to the conduits for power cables, two additional conduits, each of not less than 100 mm dia, shall be provided to carry OFC cables, one operational and one spare.

The horizontal distance between two adjacent conduits shall not be less than 75mm.

The route shall be marked by suitable retro-reflective cable markers at suitable intervals and the positions of straight through joints shall be indicated by suitable boards.

The route shall be marked by suitable RCC cable markers at suitable intervals and the positions of straight through joints shall be indicated by suitable boards.

The pulling chambers shall be 4m long, 3m width and 2.5m depth.

The top of the concrete shall be at least 1 m below the road level.

Sealing of cut outs

-Sealing of 33 kV cable and control cable cutouts is in the scope of work of contractor.

8. Transformer and specifications

33 kV 415 V Auxiliary Transformers

General

- This specification defines the main technical characteristics' required for the 33000 / 415 V transformers to be used in Auxiliary Substations (ASS).
- They shall satisfy the following requirements and shall also comply with standards in force when the transformers are manufactured, particularly IEC 60076; Latest Version, IS 2026; Latest Version and IS 111 71/1985.
- The transformer shall be Dry Type

Characteristics-

- Climatic condition- Indoor operation
- Operation - Continuous
- Winding - Aluminium
- Primary line voltage (across phases): 33 kV
- Secondary voltage, off-load line voltage at 33 kV primaries: 415 V
- Secondary voltage at full load and power factor 0.8: 400V
- Insulation rated voltage: 36V
- Frequency: 50Hz
- Withstand at industrial frequency: 70kV
- Voltage surge withstand: 170kV
- Coupling: delta-star, separate neutral (Dyn11)
- Cooling: natural
- Off load tap changer: 0, $\pm 2.5\%$ and $\pm 5\%$
- Class of insulation : F Class
- The voltage shall be adjusted by a 5 positions switch which provides -5%, -2.5%, 0, + 2.5%, and + 5% settings.
- The magnetic circuit shall be in low-loss oriented-grain silicon steel sheet. The primary and the secondary windings shall be capable of withstanding a symmetrical three-phase short-

Design, engineering, manufacture, supply, Installation, testing and commissioning of, 630KVA, 33KV/415V Compact Substation, Cabling and other accessories to be installed, its Integration with Existing NMRC SCADA at NMRC stations KP-II, Pari Chowk.

circuit regardless of the tapping selected. The circuit level at secondary side for various ratings of transformers shall be as follows:

- 315KVA 11.0kA
- 630KVA 17.4kA
- 630kVA 21.9kA
- 2000kVA 46.4Ka

The terminals shall be of the 36 kV type.

Conductors insulated at 36kV shall realize delta connection on primary side.

Secondary neutral of transformers shall be solidly earthed.

➤ **Transformer Values**

Contractor shall confirm the following characteristic for each power transformer.

- Short Circuit Voltage
- No-Load Losses
- Full Load Copper Loss

Minimum efficiency at different load conditions

i.e from 1/4 load to full load and at minimum 0.8 Power Factor = 98.20%

The connection with different terminals of transformer shall be through C C -Type or suitable connector for sufficient clearances from transformer windings. HV Connections of Transformer shall be connected through insulated cables. HV terminals shall have suitable arrangement to provide sufficient clearance to 33 kV cables from the transformer windings.

➤ **Temperature protection**

Transformers shall be fitted with a temperature protection system that allows winding temperatures to be monitored. This shall consist of two sensors placed on each low-voltage winding: one alarm sensor and one trip-out sensor. So, three alarm sensors (one per low voltage winding) and three trip-out sensors (one per low-voltage winding) shall be provided. An indicator shall be installed on the front door of the bay to indicate continuously the winding temperature. This shall be installed on the middle low voltage winding.

➤ **Transformer Cubicle**

The door shall be provided with a mechanical system interlock, to ensure that it is possible to open the door only when the protection circuit breakers on the HV side as well as LV side of the transformer are in 'Open' position. Also Opening of transformer door shall cause tripping of CB on Primary & Secondary side i.e 33KV CB and LVCB. . Enclosure shall have inspection windows to view primary and secondary sides, Temperature monitoring devices with two thresholds (alarm and tripping) must be provided and located on the upper part of the secondary windings. The cubicle shall provide protection against direct contact with the power transformer. It shall include connections for the MV lines from the protection bay and connections for the low voltage circuit.

The bimetallic strips required for connection in any case shall be provided by Contractor.

Design, engineering, manufacture, supply, Installation, testing and commissioning of, 630KVA, 33KV/415V Compact Substation, Cabling and other accessories to be installed, its Integration with Existing NMRC SCADA at NMRC stations KP-II,Pari Chowk.

8.1 Fire protection scheme & integration with SCADA/FACP

Transformer fire protection scheme.

The scope covers supply, installation, testing and commissioning of automatic clean agent flooding system considering the following when computing volume to verify suitability and to establish design limitations complete for Dry Type Transformers.

Volume of hazard area.

Specific volume of clean agent.

Discharge time and flow rates.

Design concentration and design factors.

Detector discharge tubing placement.

Locate Clean Agent supply near each hazard area.

Interface system with Main control fire alarm system, BMS & SCADA

Provide total flooding of 4.2 percent clean agent concentration by volume as per NFPA-2001.

The agent provided should conform to the below:

The Agent should have Ozone Depletion Potential of Zero.

The Agent should have a atmospheric lifetime of less than 10 Days.

The Agent should not have Global Warming Potential of more than 1.

The Agent should be Low pressure in nature.

NOTE: Clean agent based gas flooding system will be provided in transformer compartment & LT Compartment and integration of gas flooding system to SCADA/FACP.

The bidder shall submit the General arrangement drawing, control wiring drawing of distribution board (MDB). Manufacturing clearance shall be granted after approval of engineer in charge.

8.2 Distribution transformer data sheet:

33KV/415V, 630 KVA Cast Resin Dry Type Transformer

Transformer should be type tested and the report should not be more than 5 years old. Transformer shall also comply with standards in force when the transformer is manufactured, particularly IEC 60076, Latest version, IS 2026; Latest version and IS 11171/1985.

Sr. No.	Description	Unit	Particulars	To be confirmed by Bidder
1	Manufacturer's Name And Country Of Manufacture			
2	Applicable Standards & Quantity		As Per Specifications & As Per BOQ	
3	Capacity	KVA	630	
4	Secondary voltage, off-load line voltage at 33 kV primaries	v	415	

Design, engineering, manufacture, supply, Installation, testing and commissioning of, 630KVA, 33KV/415V Compact Substation, Cabling and other accessories to be installed, its Integration with Existing NMRC SCADA at NMRC stations KP-II,Pari Chowk.

5	Primary line voltage (across phases):	kV	33	
6	Method of Connection HV Winding /LV Winding or Coupling:		delta-star, separate neutral (Dyn11)	
7	Rated Frequency	Hz	50	
8	Type Of Winding / Material		Two Winding / Cop-per	
9	3 Phase / Single Phase Unit		3 Ph Unit	
10	Secondary voltage at full load and power factor 0.8	V	400	
11	Voltage Rating	kV/ kV	33 / 0.415	
12	Cooling		Natural	
14	Vector Group		Dyn11	
15	Winding Insulation (HV & LV)		Uniformly Insulated, Class F	
16	Short Circuit Current	kA	50kA	
17	Maximum Duration of Fault	Sec.	1 Sec	
18	Insulation Withstand Voltage	kV	36	
19	Rated lightning impulse withstand voltage for primary winding	KV	170	
20	Rated short duration power frequency withstand voltage for primary winding	KV	70	
	Short circuit impedance	%	6	
21	Weight			
21.a	Transformer weight	Kg	Bidder To Furnish	
22	Current Density		Bidder To Furnish	
22.a	HV	A/Cm ²		
22.b	LV	A/Cm ²		
23	Noise level	dBA	74	
24	Guaranteed Total Losses At 100% Rated Voltage And Frequency (Without Is Positive Tolerance)	kW	Bidder To Furnish	

Design, engineering, manufacture, supply, Installation, testing and commissioning of, 630KVA, 33KV/415V Compact Substation, Cabling and other accessories to be installed, its Integration with Existing NMRC SCADA at NMRC stations KP-II,Pari Chowk.

25	Guaranteed No-Load Current: A. When Excited From LV Side At 100% Rated Voltage B When Excited From LV Side At 110% Rated Voltage	A	Bidder To Furnish	
26	Guaranteed Efficiency i) At 75 °c		from 1/4 load to full load and at minimum 0.8 Power Factor = 98.20%	
27	Core:			
a	Material of Core Lamination		CRGO	
b	Insulation of Core Lamination		Bidder To Furnish	
c	Core loss in watt:	Watt	Bidder To Furnish	
	a) Normal voltage b) Maximum voltage			
d	Maximum temperature rise of core by thermometer		Bidder To Furnish	
e	Center to center distance of the core	Mm	Bidder To Furnish	
f	Magnetizing (No load) current at a) Normal Voltage b) Maximum Voltage		Bidder To Furnish	
28	Winding			
a	Class of Insulation		Class F	
b	Material		Aluminum	
c	Maximum temperature rise of Windings by resistance method		Bidder To Furnish	
29	Tapping			
a	Tapping On Winding	HV/LV	HV	
b	Whether Off-Circuit		Off Load	
c	Tapping Range	%	-5% to +5%	
d	Tapping Step	%	2.5%	
30	Parallel Operation		No	
31	Terminal Bushings		HV / LV	
a	Rated Voltage Class -	KV	33/ 0.415	
b	Rated Current Class -	A	Bidder To Specify	

Design, engineering, manufacture, supply, Installation, testing and commissioning of, 630KVA, 33KV/415V Compact Substation, Cabling and other accessories to be installed, its Integration with Existing NMRC SCADA at NMRC stations KP-II,Pari Chowk.

32	All The Accessories, Protections, Equipments - Compliance With Specification, SLD& Data Sheet Requirements.		Yes/ No	
33	Total weight of 33kV CSS	Kg	Bidder To Furnish	
34	Dimensions of CSS (LxWxH)	Mm	Bidder To Furnish	
35	Total weight of 33kV RMU	Kg	Bidder To Furnish	
36	Dimensions of RMU (LxWxH)	Mm	Bidder To Furnish	
	Climatic conditions:		Outdoor operation (Delhi NCR)	
	Operation:		continuous	

- The magnetic circuit shall be in low-loss oriented-grain silicon steel sheet.
- The primary and the secondary windings shall be capable of withstanding a symmetrical three-phase short-circuit regardless of the tapping selected.

8.2.1 Accessories

Lifting rings

Nameplate

Grounding terminal.

Frame Channels

- HV Connections of Transformer shall be connected through insulated cables
- The cable connection with different terminals of transformer shall be through C – Type or suitable connector for clearances from transformer windings. HV terminals shall have suitable arrangement to provide sufficient clearance to 33 kV cables from the transformer windings.
- Secondary neutral of transformers shall be solidly earthed.
- **Cables and terminations**

Supply & laying of 33 kV grade as per BOQ XLPE insulated PVC sheathed cable and termination of above cable at GIS end and transformer end. GTP of MV suitable for above CSS and as per E/I instruction cable shall be as be submitted before ordering.

Design, engineering, manufacture, supply, Installation, testing and commissioning of, 630KVA, 33KV/415V Compact Substation, Cabling and other accessories to be installed, its Integration with Existing NMRC SCADA at NMRC stations KP-II,Pari Chowk.

9. SCADA and signal list

The Control and Monitoring System is required to supervise, control, and acquire the various specified data from the Operational control Centre at NMRC Depot and Back up Control Centre at Sec- 148 RSS along the Line for CSS.

Under this contract, Contractor to integrate the CSS with existing Noida Metro SCADA (Siemens Make). All the equipment required to perform the said work is in the Scope of contractor.

The Scope also includes the equipments and other accessories required to interface with Metro Fiber optic backbone as per the requirement.

In order to facilitate local maintenance of the equipment and to prevent unauthorized local operations, Permissive for Local operation shall be provided for each equipment so that the field operator can carry out operation of the power equipment only after the above permission is granted from the Control Centre. SCADA system should ensure that no operation is performed without permission from Operator. For CSS automation, contractor will be required to interface with CSS OEM to ensure necessary provision in bay controllers to implement the above control logic.

Each RTU/RIO shall also have SCADA permissive switch for Local Remote mode selection.

Integrated testing of CSS with OCC & BCC should be done in accordance and coordination of NMRC O&M team.

Design, engineering, manufacture, supply, Installation, testing and commissioning of, 630KVA, 33KV/415V Compact Substation, Cabling and other accessories to be installed, its Integration with Existing NMRC SCADA at NMRC stations KP-II,Pari Chowk.

9.1 Signal List

S.N	Device	Event description	Event type			Remarks
			Digital input	Digital output	Analog input	
1	PT	R-Y Voltage			AI	
2		Y-B Voltage			AI	
3		B-R Voltage			AI	
4	EIS	close	DI			
5		Open	DI			
6	MVCB	L/R in local	DI			Common Signal in One CSS
7		Permission for local control	DI			Common Signal in One CSS
8		110V DC control voltage fail	DI			Common Signal in One CSS
9		close indication	DI			
10		Open indication	DI			
11		SF6 Gas pressure Low	DI			Common Signal in One CSS
12		SF6 Gas pressure High	DI			Common Signal in One CSS
14		Perssure Unhealthy Auto trip	DI			Common Signal in One CSS
15		CB trip circuit unhealthy	DI			
16		Trip relay operated	DI			
17		Spring discharge	DI			
18	Open command		DO			
19	close command		DO			
20	Scada permissive for local control		DO			
21	O/C&E/F Relay faulty	DI				

CSS Equipment Qty	
PT	3
EIS	2
MVCB	3
TEIS	1
Trafo	1
Discon- nector	3
RTU/RIO	1

Design, engineering, manufacture, supply, Installation, testing and commissioning of, 630KVA, 33KV/415V Compact Substation, Cabling and other accessories to be installed, its Integration with Existing NMRC SCADA at NMRC stations KP-II,Pari Chowk.

22		O/C Protection operated	DI		
23		E/F Protection operated	DI		
24		Differential Relay Faulty	DI		
25		Differential Protection operated	DI		
26	TEIS	close indication	DI		
27		Open indication	DI		
28	Transformer	Winding temp high alarm	DI		
29		Winding temp high auto trip alarm	DI		
30	Disconnector	Disconnecter position open indication	DI		
31		Disconnecter position close indication	DI		
32		Disconnecter open command		DO	
33		Disconnecter close command		DO	
34	RTU/RIO	RTU/RIO PS1 Status	DI		
35		RTU/RIO PS2 Status	DI		
36		RTU RIO door status	DI		
37		RTU RIO L/R status	DI		
38	LV ACB	position open indication	DI		
39		position close indication	DI		
40		open command	DI		
41		close command	DI		

Above signal list is tentative in nature. Contractor to submit the signal list as per the CSS design for approval.

Design, engineering, manufacture, supply, Installation, testing and commissioning of, 630KVA, 33KV/415V Compact Substation, Cabling and other accessories to be installed, its Integration with Existing NMRC SCADA at NMRC stations KP-II,Pari Chowk.

10. Plan submission and Schedule of work

CSS Location	Start of Civil Work	Start of submission of vendor proposal for equipment drawing etc for approval	Completion of Delivery of Major Material at site like CSS, Cables, Panels	Completion of Erection of CSS, cabling & all civil works.	Testing, Commissioning charging of CSS	Integrated Testing & commissioning
KP-2	1.5 Months	0.5 Months	6 months	6.5 months	7 months	8 months
Pari Chowk	1.5 Months	0.5 Months	6 months	6.5 months	7 months	8 months

****All number refer from LOA date of Work**

Sl. No.	Submission	Remarks
01	Factory Testing Programme	With in one month of LOA
02	Site Testing and Commissioning programm	With in one month of LOA
03	Procurement Manufacturing Delivery Plan	With in one month of LOA
04	Construction and Installation Plan	With in one month of LOA
05	Integrated Testing and commissioning Plan	With in one month of LOA
06	DLP management Plan	With in three months of LOA
07	Design Documents submission programme	With in 15 days of LOA
08	AC Simulation study Report	With in one month of LOA
8a.	Preliminary AC Simulation study Report	With in one month of LOA
8b.	Final AC Simulation study Report	With in three months of LOA
9	Contactora project Plan	With in 15 days of LOA

10.1 Scope of Work for DLP cum CAMC

Scope of work includes preventive and corrective maintenance required for **executed work.**

- All manpower, material, testing equipment & spare are in the scope of contractor during DLP cum CAMC period.
- During DLP cum CAMC contractor will depute prescribed Manpower as in table below to attend breakdown and preventive maintenance activity.

Design, engineering, manufacture, supply, Installation, testing and commissioning of, 630KVA, 33KV/415V Compact Substation, Cabling and other accessories to be installed, its Integration with Existing NMRC SCADA at NMRC stations KP-II,Pari Chowk.

Sr.No.	Staff Designation	No. of Person to be deployed	Minimum Qualification
1	Engineer	1	Degree with 5 year experience of similar nature.
2	Skilled Technician	1 per shift	ITI with 3 year experience of similar nature.

10.2 Duties of Engineer

He/She shall be in-charge of Contractor CSS Maintenance team responsible for safe and efficient maintenance of CSS. He/She should be fully conversant with the details of CSS and also the rules and procedure for efficient CSS maintenance.

- 1) Corrective & Preventive maintenance in accordance of OEM and employer.
- 2) To attend Breakdown maintenance work.
- 3) Ensure advance planning of Preventive Maintenance with a view to avoid CSS failure in consultation with TPC.
- 4) Detailed inspection of CSS and submission of Monthly inspection report to employer.
- 5) Instruct, train and supervise staff under him.
- 6) Arrange and ensure Maintenance tool and equipment required for Preventive & Corrective Maintenance.
- 7) Keep employer fully inform of all important developments and seek their guidance when required.
- 8) To ensure submission of following reports**
 - i) Failure analysis report
 - ii) Unusual Occurrence report
 - iii) Power Block & PTW report
 - iv) Accidental Report
 - v) Staff Position Report
- 9) To ensure proper competency of staff under him and arrange training when required.
- 10) Carryout other duties assign to him by employer.

10.3 Duties of Skilled Technician

- 1) To have requisite competency to enable them working independently.
- 2) To be convergent with safety rules pertaining to his work and capable to independently perform operation of CSS & attend miner repair. He must be always equipped with tools required to perform the same.
- 3) Make general check of all earthing connection.
- 4) Carryout any other duty assign to him.

Design, engineering, manufacture, supply, Installation, testing and commissioning of, 630KVA, 33KV/415V Compact Substation, Cabling and other accessories to be installed, its Integration with Existing NMRC SCADA at NMRC stations KP-II, Pari Chowk.

11. Statutory approval, inspection & tests

All necessary statutory approvals shall be taken by the contractor. The employer shall facilitate only.

Description	TYPE OF TEST			
	Type	Routine	On Site	Special
Temperature rise*	√			
Lighting impulse withstand voltage test*	√			
Separate-source voltage withstand test		√	√	
Measurement of winding resistance test		√		
Measurement of voltage ratio and check of phase displacement		√		
Measurement of no load loss and current		√		
Visual inspection		√	√	
Short circuit withstand test				√

The bidder shall submit the General arrangement drawing, control wiring drawing of distribution board (MDB). Manufacturing clearance shall be granted after approval of engineer in charge.

• Indicating lamps

Indicating lamps shall be multiple LED type. All indicating lamps shall be suitably rated so that the indication is clearly visible from the side and front at a distance of not less than 3 m in a room.

The colours of indicating lamps for red, yellow, blue phases, ACB on, off and trip shall be red, yellow, blue, red, green and amber respectively.

11.1 Inspection & tests certificates

All equipment shall be completely assembled, wired, adjusted and tested at the factory as per the relevant IS/IEC standards. The following tests shall however be carried out as a minimum. All the tests being conducted shall clearly be brought out in the Quality Assurance Plan (QAP) by Bidder. The category of test i.e whether it is a routine test or type test or both, must also be brought out clearly in the QAP with specific mention of relevant standard Number against each test.

a)	BOM verification	100 % Witness
b)	Dimensional check , Painting thickness , finish quality & workmanship	100 % Witness
c)	One Set of Manufacturer's Test certificates for major bought out equipment shall be made available during inspection	100 % Review
d)	All Routine & acceptance tests in including Load test for 33kV CSS & RMU set as per relevant standards shall be conducted.	100 % Witness
e)	All type tests shall be as per the relevant IS/IEC standard .	100 % Review

Design, engineering, manufacture, supply, Installation, testing and commissioning of, 630KVA, 33KV/415V Compact Substation, Cabling and other accessories to be installed, its Integration with Existing NMRC SCADA at NMRC stations KP-II,Pari Chowk.

11.2 Test certificates

Test certificates for the type tests (as per Latest & relevant standards) of not older than 5years (as on date of enquiry) issued by any recognized laboratory for the similar rating 33kV CSS & 33kV RMU set shall be furnished for NMRC's review along with technical data sheets. If Type test certificates are not available same shall be conducted by vendor at his own cost in any recognized laboratory.

Units shall be type tested in accordance with the IEC standards. Following type test certificates shall be provided.

- Short time and peak withstand current test
- Temperature rise test
- Dielectric test
- Test of apparatus (CB & ES)
- Arc fault test
- Measurement of resistance of main ckt.
- Mechanical endurance test
- Duty cycle test.
- Internal arc test for HT chamber
- Degree of protection.

Type reports of Transformer and LT switchgear shall be furnished as per relevant IEC/IS standards.

11.2.1 Shop Tests

All equipment and material shall be subjected to manufacturer's standard shop tests. Tests shall be carried out at the manufacturer's works during and after completion of manufacture of different component parts in accordance with the requirements of relevant codes, and wherever not specified in the said codes/regulations, the tests shall be carried out in accordance with the standards approved by the Purchaser.

12. Drawings, manuals and General requirements

To be submitted for Approval and Distribution

Sl.no	Document to be submitted for Approval	Approval/ Information
i.	Electrical single line diagram showing rating of all equipment.	Approval
ii.	GA / OGA Drawing and BOM of CSS	Approval
iii	Data Sheets of PSS,HT breaker, Transformer & LT breakers	Approval
Iv	Foundation Plan & Loading Details of PSS	Information
V	PSS area Layout and Cross Section considering acoustic enclosure, exhaust piping, cable trenches, cable trays, fuel trenches etc.	Approval
Vi	Any other relevant drawings, documents or data necessary for satisfactory installation, operation and maintenance	Information
Vii	Type test certificates	Information

Design, engineering, manufacture, supply, Installation, testing and commissioning of, 630KVA, 33KV/415V Compact Substation, Cabling and other accessories to be installed, its Integration with Existing NMRC SCADA at NMRC stations KP-II,Pari Chowk.

viii	O&M, Storage & Erection instruction manual	Information
ix	As built & Commissioned / final document	Information

Note:

- The manuals shall clearly indicate method of installation, check-ups and tests to be carried out before commissioning of the equipment.
- The Vendor may note that the drawings, data and manuals listed herein are minimum requirements only.
- The Vendor shall ensure that all other necessary write-ups, curves, calculations and information required to fully describe the equipment offered are submitted with his bid.

12.1.1 General Requirements:

- Compact Sub-Station & RMU shall be outdoor plinth mounted type.
- However, Supervision of erection, testing and commissioning is in the scope of Bidder. Further, the Vendor shall furnish the foundation details & foundation bolts & accessories.
- Package sub-station & RMU will be complete with the internal interconnections & earthing (GI) and extending of earth bar of Neutral and body terminals to the frame of the CSS for connecting to the earth pits. External earthing from CSS frame to earth pit.
- Vendor shall assemble the Compact substation & RMU at factory and no assembly of the same shall be allowed at site.
- Required technical data sheet of the transformer, HV/ MV switchgear, relay etc. should be furnished with the offer.
- **Colour of paint to be mentioned in the offer and to be decided mutually. Tentative paint shade shall be RAL-7032.**
- **The CSS & RMU should be SCADA compatible.**
- Vendor shall supply suitable & required no. of HT & LT Cable termination kits along with CSS for HT & LT Cable terminations.

12.1.2 Pre-Dispatch Inspection:

Vendor shall offer for pre-dispatch inspection at vendor's works. Only after the equipment's are cleared by NMRC in writing, the vendor can dispatch the equipment. Routine tests to be conducted and original test certificates to be submitted.

12.1.3 Training

Atleast 4 NMRC persons shall be trained at vendor's principles in the area of design, maintenance, and operation & transformer replacement of Compact Substation for a period of two working days.

Atleast 6 persons shall be trained at NMRC site for a period of two working days.

Design, engineering, manufacture, supply, Installation, testing and commissioning of, 630KVA, 33KV/415V Compact Substation, Cabling and other accessories to be installed, its Integration with Existing NMRC SCADA at NMRC stations KP-II,Pari Chowk.

13. Tentative Make of components:

S.NO	ITEM	RECOMMENDED ELECTRICAL VENDOR
1	H.T Breaker	Siemens/Schnieder/ABB/L&T/Asefa/Alstom/NMRC vendors or eq.
2	Dry Type Transformer	Raychem/Siemens/Schnieder/ABB/L&T/Crompton/Asefa/Voltamp/Alstom/Powerstar/ NMRC vendors or eq.
3	LT Breaker	L&T/ABB/Siemens/Schnieder/ NMRC vendors or eq.
4	Auxiliary Relays	ABB, Jyoti, Areva, NMRC vendors or eq,
5	Bi-metal Relays	ABB, BCH Electric, C&S Electric, Larsen & Toubro Ltd., SchneiderElectric, Siemens, GE/ NMRC vendors or eq.
6	Contactors	ABB, BCH Electric, C&S Electric, GE India, Larsen & Toubro, SchneiderElectric, Siemens/ NMRC vendors or eq.
7	Control switches (Breaker)	Areva T&D India Ltd, Reliable Electronic Components, Switron Devices, Alstom, Kaycee/ NMRC vendors or eq.
8	Control switches/Selector switches	Areva T&D, Hotline Switchgear & Controls, Kaycee Industries Ltd.,Larsen & Toubro, Reliable Electronic Components Pvt. Ltd., SiemensLimited, Switron Devices/ NMRC vendors or eq.
9	Earth LeakageCircuit Breaker	Datar Switchgear, Indo Asian Fusegear ,Legrand, Havell's, ABB,Siemens, Schneider/ NMRC vendors or eq.
10	Fuses	GE India Industrial, Indo Asian Fusegear., Larsen & Toubro, Siemens,Cooper Bussman/ NMRC vendors or eq.
11	Heavy duty switches	C&S Electric, Indo Asian Fusegear, Larsen & Toubro, Siemens/ NMRC vendors or eq.
12	MCBs	Datar Switchgear/ Havell's/ Indiana Current Control/ Indo Asian Fusegear/ Legrand/ Standard Electricals/ Schneider/ ABB/ Siemens/ NMRC vendors or eq.
13	MCCBs	GE India, Siemens, Larsen & Toubro, Schneider Electric, ABB/ NMRC vendors or eq.
14	Meters	Automatic Electric/ MECO Instruments/ Nippen/Electrical InstrumentsCo./ Rishabh Instruments/ NMRC vendors or eq.
15	Protection Relays (Conventional & Numerical)	ABB/ Areva/ Easun Reyrolle/ Larsen & Toubro (P&B), Schneider Electric/ Siemens/ Schweitzer Engg./ NMRC vendors or eq.

Design, engineering, manufacture, supply, Installation, testing and commissioning of, 630KVA, 33KV/415V Compact Substation, Cabling and other accessories to be installed, its Integration with Existing NMRC SCADA at NMRC stations KP-II,Pari Chowk.

16	Push buttons & Indicating lamps	BCH Electric/ C& S Electric/ Hotline Switchgear & Controls/ Larsen & Toubro/ Precifine Products/ Schneider Electric India/ Shri Tulsi Switchgears./ Siemens/ Teknic Controls/ Essen Deinki/ NMRC vendors or eq.
17	Fuse-switch combination	ABB/ C&S Electric/ Havel's/ Indo Asian Fuse gear/ Larsen & Toubro/ Schneider Electric India/ Siemens/ Standard Electricals/ GE/ NMRC vendors or eq.
18	Timers	BCH Electric./ Electronic Automation Pvt. Ltd./Larsen & Toubro Ltd.,Siemens Limited/ NMRC vendors or eq.
19	CT & PTs (MV)	Gilbert & Maxwell Electricals Kalpa Elektrikal., Kappa Electricals, Narayan Powertech, Pragati Electricals Precise Electricals, Silkaans Electricals., NMRC vendors or eq.
20	Panel	NMRC vendors or eq.
21	Cable	NMRC vendors or eq.

Note:

- **Approved NMRC vendor list is available on NMRC website.**
- Vendor shall strictly follow the list of makes for equipment's as specified above and **above mentioned MAKE or Eq. must follow all the pre requites & standard guide-lines.**
- For components other than the above, vendor shall submit past track record for the proposed sub-vendors and obtain written approval from NMRC before placing order.

Design, engineering, manufacture, supply, Installation, testing and commissioning of, 630KVA, 33KV/415V Compact Substation, Cabling and other accessories to be installed, its Integration with Existing NMRC SCADA at NMRC stations KP-II, Pari Chowk.

14. Tentative Drawings of the CSS work, Existing 33 KV line SLD, GTP of Cable:

14.1 Tentative Drawings of the CSS work

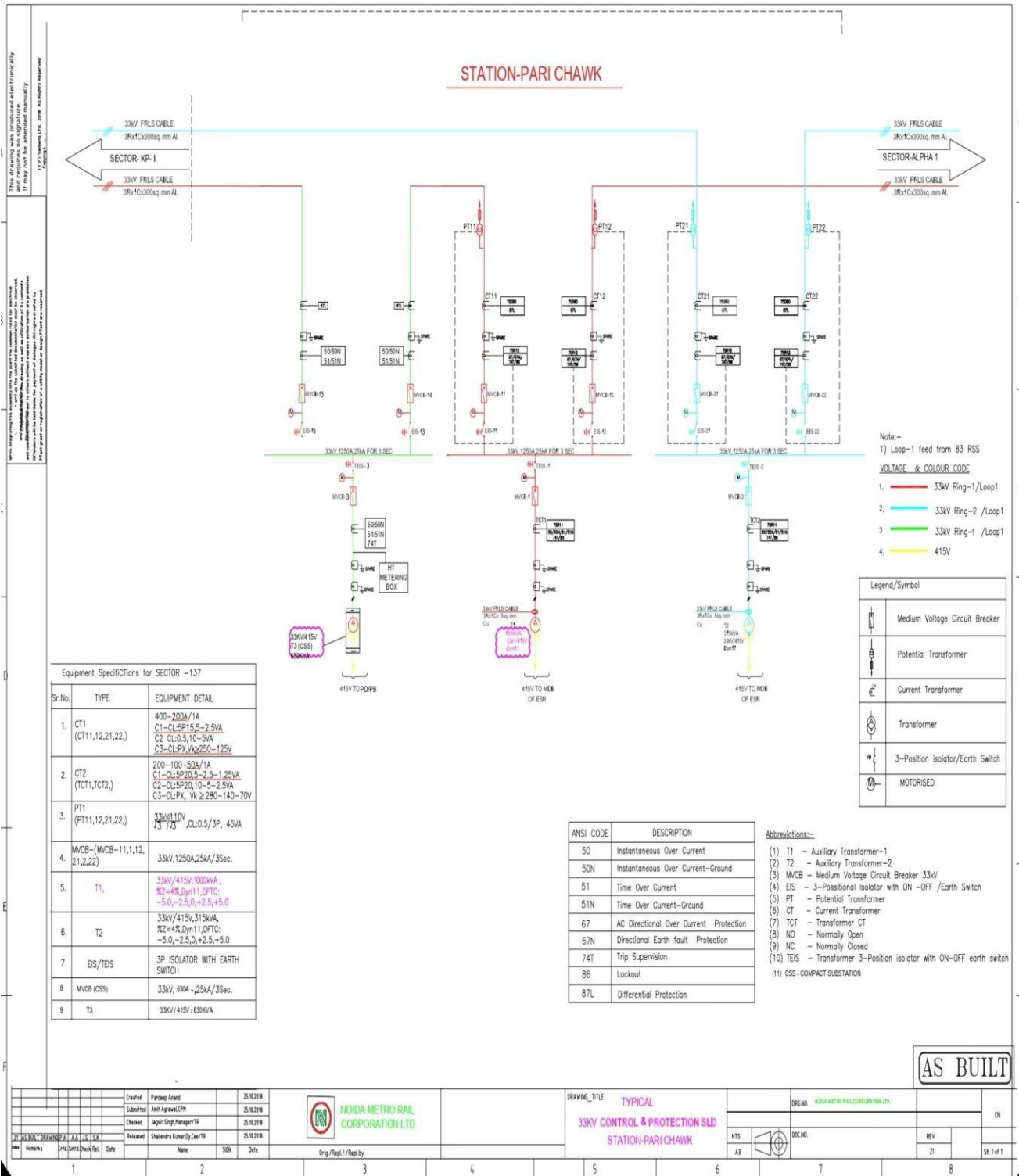

Design, engineering, manufacture, supply, Installation, testing and COMMISSIONING of, 630KVA, 33KV/415V Compact Substation, Cabling and other accessories to be installed, its Integration with Existing NMRC SCADA at NMRC stations KP-II, Pari Chowk.

14.2 Existing 33 KV line SLD

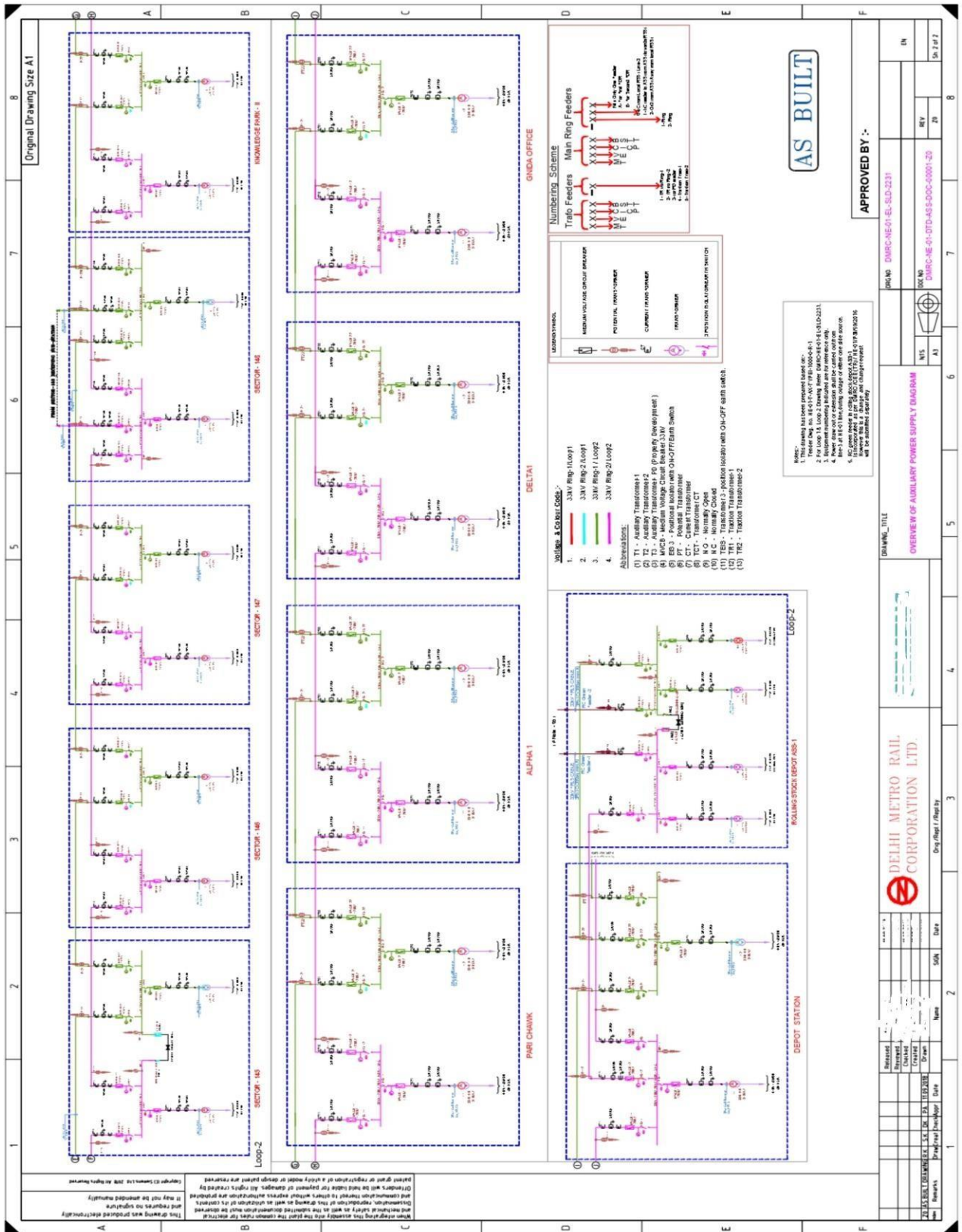

Design, engineering, manufacture, supply, Installation, testing and commissioning of, 630KVA, 33KV/415V Compact Substation, Cabling and other accessories to be installed, its Integration with Existing NMRC SCADA at NMRC stations KP-II,Pari Chowk.

14.3 GTP of 33 KV Cable

14.3.1 General GTP-Page-1

Sl. No.	Description	Unit	Data Offered
1	Manufacturer		
2	Reference Standard		Generally as per IEC 60840 / IEC 60502-2
3	Voltage Grade (U ₀ /U (U ₂))	KV	26/45 (52)
4	Operating Voltage	KV	27.5
5	Cable type		Copper XLPE Insulated Cable
6	Manufacturing Process		Dry Curing
7	Cable Size	Sq mm	240
8.1	Conductor Material		Annealed Plain Copper as per IEC 60228
8.2	Conductor Material	mm	Extruded semi-conducting compound
9.1	Core Screen		Extruded semi-conducting compound (Bonded Type)
9.2	Thickness of conductor Screen	mm	0.3 nom.
10.1	Insulation		XLPE
10.2	Minimum thickness of insulation	mm	10 min.
11.1	Insulating Envelope screen		Non-metallic part of semi- conducting material plus metallic part consisting of standard wire and copper tape, rated to carry a short circuit current of 14 kA for 3 sec
11.2	Thickness of insulation screen	mm	0.3 nom.
12.1	Outer sheath	mm	Black FRLS PVC type ST-2
12.2	Thickness Outer Sheath*	mm	1.96 min.
13	Nominal overall diameter of Cable	mm	55 ± 2 mm
14	Approx weight of Cable	kg/km	5800 approx.
15	Minimum bending radius	mm	20 times OD
16	Delivery Drum Length	mtrs.	1000 ± 5% (In Steel drums)
17	Embossing / Printing (at every 1 mtrs)**		"LOGO" "MANUFACTURER'S NAME" "XLPE CABLE" "KV" "CABLE SIZE" "CABLE TYPE" "YEAR" "NMRC" "PHASE- 1/2/3"

* Non Standard Length shall be 5% of the Order Quantity or no length less than 100 mtrs

* Order Quantity tolerance shall be ±5% or as per the PO

* For armoured cables, minimum thickness of outer sheath has to be maintained as per Cl. 17.5.3 (b) of IEC 60502-2.

** Phase Numbering of 1 / 2 / 3 shall be provided for respective phases as required. Customer has to specify the individual drum lengths during PO placement.

Sequential length marking shall be provided through printing at every 1 mtr on the outer sheath

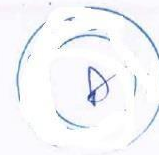

Design, engineering, manufacture, supply, Installation, testing and commissioning of, 630KVA, 33KV/415V Compact Substation, Cabling and other accessories to be installed, its Integration with Existing NMRC SCADA at NMRC stations KP-II,Pari Chowk.

14.3.2 GTP of several 33 KV Cable Size-Page-1

DESCRIPTION	UNIT	DATA OFFERED			
Manufacturer					
Cable Size	Sq.mm.	400	300	95	240
Cable Type		Copper XLPE Insulated PVC Sheathed Cables	Aluminium XLPE Insulated PVC Sheathed Cables	Copper XLPE Insulated PVC Sheathed Cables	Copper XLPE Insulated PVC Sheathed Cables
Voltage Grade U0/U (U2)	KV	18/30 (36)	18/30 (36)	18/30 (36)	1.8/3.0 (3.6)
Reference Standard		Generally as per IEC 60502-2	Generally as per IEC 60502-2	Generally as per IEC 60502-2	Generally as per IEC 60502-1
No. and cross sectional area of conductor	sq.mm.	1C x 400	1C x 300	1C x 95	1C x 240
Conductor Material		Annealed Plain Copper as per IEC 60228	E.C Grade Aluminium as per IEC 60228	Annealed Plain Copper as per IEC 60228	Annealed Plain Copper as per IEC 60228
Shape		Stranded Circular Compacted	Stranded Circular Compacted	Stranded Circular Compacted	Stranded Circular Compacted
Class/Standard		Class 2/ IEC 60228	Class 2/ IEC 60228	Class 2/ IEC 60228	Class 2/ IEC 60228
Nominal Diameter of Conductor	mm	Conductor diameter shall be so chosen so as to meet the conductor resistance requirement as per IEC 60228			
Conductor Screen Materials		Extruded semi-conducting compound	Extruded semi-conducting compound	Extruded semi-conducting compound	Extruded semi-conducting compound
Nominal thickness of conductor screen	mm	0.7 (nom.)	0.7 (nom.)	0.7 (nom.)	0.3 (nom.)
Insulation Material		Extruded XLPE Compound	Extruded XLPE Compound	Extruded XLPE Compound	Extruded XLPE Compound
Nominal thickness of insulation	mm	8.0 (nom.)	8.0 (nom.)	8.0 (nom.)	2.0 (nom.)
Nominal Diameter Over Insulation	mm	41.5 (approx.)	38.0 (approx.)	29.0 (approx.)	23.5 (approx.)
Insulation screen material (Non-Metallic)		Extruded semi-conducting compound (Bonded Type)	Extruded semi-conducting compound (Bonded Type)	Extruded semi-conducting compound (Bonded Type)	Extruded semi-conducting compound (Bonded Type)
Nominal Thickness of Insulation screen	mm	0.7 (nom.)	0.7 (nom.)	0.7 (nom.)	0.3 (nom.)
Nominal Thickness of Tape	mm	0.04 approx. for Open Helix Copper Tape used as a binder Tape over Copper Wire Screen	0.04 approx. for Open Helix Copper Tape used as a binder Tape over Copper Wire Screen	0.04 approx. for Open Helix Copper Tape used as a binder Tape over Copper Wire Screen	0.04 approx. for Open Helix Copper Tape used as a binder Tape over Copper Wire Screen
No. and diameter of Copper Wire Screen wires	No./mm	Number of Wires, Diameter & Cross sectional area of Copper Wire Screen shall be so chosen so as to meet the requirement of earth fault current of 1 kA for 3 sec.			
Cross sectional Area	Sq.mm				
Outer sheath material		FRLS PVC type ST-2	FRLS PVC type ST-2	FRLS PVC type ST-2	FRLS PVC type ST-2
Nominal Thickness of outer sheath*	mm	1.88 (min.)	1.8 (min.)	1.6 (min.)	1.4 (min.)
Colour of Outer Sheath		Black			
Nominal overall diameter (±2mm)	mm	55	50	41	34
Minimum bending radius	mm	20 times OD			15 times OD
Max. DC conductor resistance at 20 deg.C	Ohm/km	0.047	0.100	0.193	0.0754
Star reactance per phase at 50 Hz	Ohm/km	0.113	0.117	0.141	0.099
Capacitance per phase	uf/km	0.259	0.23	0.157	0.619
Charging current per phase at U0, 50 Hz	A/km	1.46	1.29	0.892	0.35
Max. Current rating in Air	A	845 @ 30 Deg.C	577 @ 30 Deg.C	361 @ 30 Deg.C	641 @ 30 Deg.C
Max. Current rating in Ground	A	590 @ 20 Deg.C	414 @ 20 Deg.C	285 @ 20 Deg.C	469 @ 20 Deg.C



Design, engineering, manufacture, supply, Installation, testing and commissioning of, 630KVA, 33KV/415V Compact Substation, Cabling and other accessories to be installed, its Integration with Existing NMRC SCADA at NMRC stations KP-II,Pari Chowk.

14.3.3 GTP of different 33 KV Cable Size-Page-2

DESCRIPTION	UNIT	DATA OFFERED			
Max. Conductor temperature on continuous	Deg.C	90			
Max. Conductor temperature in short circuit	Deg.C	250			
Max. Short circuit current rating (Conductor)					
t = 0.1 sec	kA	180.9	89.6	42.9	108.5
t = 0.2 sec	kA	127.9	63.3	30.4	76.7
t = 0.5 sec	kA	80.9	40.1	19.2	48.5
t = 1.0 sec	kA	57.2	28.32	13.58	34.32
Delivery Drum length	mts.	1000 ± 5% (in Non returnable Steel drums)			
Type of Curing		Dry Curing	Dry Curing	Dry Curing	Steam Curing
Embossing / Printing (at every 1 mtrs.) ¹⁾		"LOGO" "MANUFACTURER'S NAME" "XLPE CABLE" "KV" "CABLE SIZE" "CABLE TYPE" "YEAR" "NMRC" "PHASE- 1/2/3"			

¹⁾ Non Standard Length shall be 5% of the Order Quantity or no length less than 100 mtrs

²⁾ Order Quantity tolerance shall be ± 5% or as per the PO

³⁾ For armoured cables, minimum thickness of outer sheath has to be maintained as per Cl. 17.5.3 (b) of IEC 60502-2.

⁴⁾ Phase Numbering of 1 / 2 / 3 shall be provided for respective phases as required. Customer has to specify the individual drum lengths during PO placement.

Sequential length marking shall be provided through printing at every 1 mtr on the outer sheath



Design, engineering, manufacture, supply, Installation, testing and commissioning of, 630KVA, 33KV/415V Compact Substation, Cabling and other accessories to be installed, its Integration with Existing NMRC SCADA at NMRC stations KP-II,Pari Chowk.

15. Section 7: Draft Contract Agreement

THIS AGREEMENT made on the day of..... 2024 at Noida, District Gautam Budh Nagar, Uttar Pradesh Between **Noida Metro Rail Corporation Limited** (Hereafter referred to as "NMRC"), a company incorporated under Companies Act 2013, vide corporate identification Number: U60231UP2014SGC066849 and having its registered office at **Block-III, 3rd Floor, Ganga Shopping Complex, Sector-29, Noida -201301, District Gautam Budh Nagar, Uttar Pradesh, India** represented by of the company, by virtue of his designation and authorization by, **Managing Director, NMRC** (hereinafter called as the "Employer"), which expression shall unless excluded by or repugnant to the context or meaning thereof be deemed to include its successors and permitted assigns) of the one part,

AND

..... having its registered office at, represented by (herein after called the "**Contractor**", which expression shall unless excluded by or repugnant to the context or meaning thereof be deemed to include its successors and permitted assigns) of the other part. WHEREAS the Employer desires that the Works known as the "....." should be executed by the Contractor and has accepted a contract by the Contractor for the execution and completion of these Works.

The Employer and the Contractor agree as follows:

1. In this Agreement words and expressions shall have the same meanings as are respectively assigned to them in the Contract documents referred to.
2. The following documents shall be deemed to form and be read and construed as part of this Agreement -

Reference:

- (i) Tender No. Dated
- (ii) Bid Documents duly accepted and submitted by dated
- (iii) The Bidding Documents which include all the Sections specified below:
 - a. Section 1: General Information
 - b. Section 2: Terms of Reference
 - c. Section 3: Instructions to Bidders
 - d. Section 4: Qualification, Evaluation and Selection Process
 - e. Section 5: Special Conditions of Contract
 - f. **Error! Reference source not found.**
 - g. Section 7: Draft Contract Agreement
 - h. Section 8: Appendix and Forms
 - i. General Conditions of Contract (GCC)
 - j. Safety, Health and Environment Management (SHE)
 - k. Amendment/ Modification, if any
- (iv) Notice of Award (.....) issued by NMRC
- (v) Letter of Acceptance of NOA (.....) given byto NMRC
- (vi) Any other admitted correspondence documents between NMRC and the Bidder.

Design, engineering, manufacture, supply, Installation, testing and commissioning of, 630KVA, 33KV/415V Compact Substation, Cabling and other accessories to be installed, its Integration with Existing NMRC SCADA at NMRC stations KP-II,Pari Chowk.

3. Duration of Contract

The Corporation intends to appoint a Contractor to NMRC for a period of Eight Months.

4. Price Schedule

NMRC shall consider the following Total Contract Price, as quoted by the Contractor as part of financial bid.

5. The courts at District Gautam Budh Nagar, Uttar Pradesh shall have the exclusive jurisdiction to try all disputes arising out of this agreement between the parties.

6. In consideration of the payments to be made by the Employer to the Contractor as specified in this Agreement, the Contractor hereby covenants with the Employer to execute the Works and to remedy defects therein in conformity in all respects with the provisions of the Contract and Notice of Award issued. **"Any conditions, deviation, assumption, exclusion, suggestion of alternative clauses, request of amendments in conditions & specifications of work submitted by bidders along with his Technical Bid or Financial bid, which is different from the Tender Document, Corrigendum, Addendum uploaded by NMRC on the E-Tender Portal (<http://etender.up.nic.in>) or www.nmrcnoida.com and any other correspondence in this regard, shall not be treated as a part of the contract Agreement & shall not be binding upon NMRC in anyway whatsoever at any stage of work during execution or thereafter."**

7. The Employer hereby covenants to pay the Contractor in consideration of the execution and completion of the Works, the Contract Price or such other sum as may become payable under the provisions of the Contract at the times and in the manner prescribed by the Contract and NOA.

IN WITNESS where of the parties hereto have caused this Agreement to be executed in accordance with the laws of India on the day, month and year specified above.

For and on behalf of the Contractor
Signature of the authorized official

For and on behalf of the Employer
Signature of the authorized official

Name of the official

Name of the official

Stamp/Seal of the contractor

Stamp/Seal of the Employer

In the presence of:

In the presence of:

Sign of Witness 1 _____

Sign of Witness 1 _____

Name _____

Name _____

Address _____

Address _____

Design, engineering, manufacture, supply, Installation, testing and commissioning of, 630KVA, 33KV/415V Compact Substation, Cabling and other accessories to be installed, its Integration with Existing NMRC SCADA at NMRC stations KP-II,Pari Chowk.

Sign of Witness 2_____

Sign of Witness 2_____

Name_____

Name_____

Address_____

Address_____

Design, engineering, manufacture, supply, Installation, testing and commissioning of, 630KVA, 33KV/415V Compact Substation, Cabling and other accessories to be installed, its Integration with Existing NMRC SCADA at NMRC stations KP-II, Pari-Chowk.

16. Section 8: Appendix and Forms of Tender

16.1 Appendix 1: Metro Alignment



Fig: The Upcoming Metro Line

Please Note: The map shown above is indicative (not to scale)

Design, engineering, manufacture, supply, Installation, testing and commissioning of, 630KVA, 33KV/415V Compact Substation, Cabling and other accessories to be installed, its Integration with Existing NMRC SCADA at NMRC stations KP-II, Pari Chowk.

16.2 Appendix 2: Quality Assurance

The Contractor shall implement a Project Quality Management Plan in accordance with ISO9001 "Quality System - Model for Quality Assurance in Design/Development, Production, Installation and Servicing" to ensure that all materials, workmanship, plant and equipment supplied, and work done under the contract meets the requirements of the contract. This plan shall apply to all activities related to the quality of items, including designing, purchasing, inspecting, handling, assembling, testing, storing, and shipping of materials and equipment and different elements of maintenance work and installations of system components.

The Quality Plan to be prepared by the Contractor and submitted to the Engineer shall follow the requirements of ISO 9000 and address each element therein.

Registration of the Contractor's organisation, or subcontractors or sub-consultants is not required for this Project, but the Project Quality Management Plan as submitted shall meet the intent of the ISO 9000 requirement in that there is a comprehensive and documented approach to achieving the project quality requirements.

16.3 Quality Assurance Management Plan

The Project Quality Management Plan (PQMP) shall as a minimum address the quality system elements as required by ISO 9001, generally noting the applicability to the Contractor's Works Programme for the Project. Procedures or Quality Plans to be prepared by others (Suppliers, Subcontractors, and Sub-consultants) and their incorporation in the overall PQMP shall be identified.

The Contractor shall provide and maintain a Quality Assurance Plan (QA) to regulate methods, procedures, and processes to ensure compliance with the Contract requirements. The QA Plan, including QA written procedures, shall be submitted to the Engineer for his review.

Adequate records shall be maintained in a readily retrievable manner to provide documented evidence of quality monitoring and accountability. These records shall be available to Employer at all times during the term of the Contract and during the Defects Liability Period and for a five-year period thereafter.

The Plan shall identify:

- a. Design Process: that control, check and verify the accuracy, completeness and integration of the design shall be performed by certified personnel and in accordance with documented procedure that have the written consent of the Engineer.
- b. Special Processes: that control or verify quality shall be performed by certified personnel and in accordance with documented procedures that have the written consent of the Engineer;
- c. Inspection and Test: Inspection and testing instructions shall provide for reporting non-conformances or questionable conditions to the Engineer; Inspection shall occur at appropriate points in the installation sequence to ensure compliance with drawings, test specifications, process specifications, and quality standards. The Engineer shall designate, if necessary, inspection hold points into installation or inspection planning procedures;
- d. Receiving Inspection: These procedures shall be used to preclude the use of nonconforming materials and to ensure that only correct and accepted items are used and installed;
- e. Identification and Inspection Status: a system for identifying the progressive inspection status of equipment, materials, components, subassemblies, and assemblies as to their acceptance, rejection, or non-inspection shall be maintained;

Design, engineering, manufacture, supply, Installation, testing and commissioning of, 630KVA, 33KV/415V Compact Substation, Cabling and other accessories to be installed, its Integration with Existing NMRC SCADA at NMRC stations KP-II,Pari Chowk.

- f. Identification and Control of Items: an item identification and traceability control shall be provided;
- g. Handling, Storage, and Delivery: provide for adequate work, surveillance and inspection instructions.
- h. The Plan shall ensure that conditions adverse to quality such as failures, malfunctions, deficiencies, deviations, and defects in materials and equipment shall be promptly identified and corrected.
- i. The Plan shall provide for establishing and maintaining an effective and positive system for controlling non-conforming material including procedures for the identification, segregation, and disposal of all non-conforming material. Dispositions for the use or repair of nonconforming materials shall require the Engineers consent.

16.4 Plan Implementation and Verification

The Plan shall clearly define the QA Organisation. Management responsibility for the QA shall be set forth on the Contractor's policy and organisation chart. The Plan shall define the requirements for QA personnel, their skills and training. Records of personnel certifications shall be maintained and monitored by the QA personnel. These records shall be made available to the Engineer for review, upon request.

The QA operations shall be subject to the Engineers, Employer or Employer's authorised representative's verification at any time, including: surveillance of the operations to determine that practices, methods and procedures of the plan are being properly applied; inspection to measure quality of items to be offered for acceptance; and audits to ensure compliance with the Contract documents.

The contractor's Quality Audit Schedule shall be submitted to the Engineer for consent weekly or more frequently as required.

The results of Quality Audits shall be summarized in the Contractor's weekly reports.

The Contractor shall provide all necessary access, assistance and facilities to enable the Engineer to carry out on-site and off-site surveillance of Quality Assurance Audits to verify that the quality system which has the consent of the Engineer is being implemented fully and properly.

Design, engineering, manufacture, supply, Installation, testing and commissioning of, 630KVA, 33KV/415V Compact Substation, Cabling and other accessories to be installed, its Integration with Existing NMRC SCADA at NMRC stations KP-II, Pari-Chowk.

17. Form 1: Letter of Proposal Submission

[Location, Date]

To

ED

Noida Metro Rail Corporation (NMRC) Limited
Block-III, 3rd Floor, Ganga Shopping Complex, Sector-29,
Noida - 201301
District Gautam Budh Nagar, Uttar Pradesh

Subject: Design, engineering, manufacture, supply, Installation, testing and commissioning of, 630KVA, 33KV/415V Compact Substation, Cabling and other accessories to be installed, its Integration with Existing NMRC SCADA at NMRC stations KP-II, Pari Chowk.

Dear Sir,

We, the undersigned, offer to **Design, engineering, manufacture, supply, Installation, testing and commissioning of, 630KVA, 33KV/415V Compact Substation, Cabling and other accessories to be installed, its Integration with Existing NMRC SCADA at NMRC stations KP-II, Pari Chowk.** in accordance with your RFP Document dated..... and our Proposal. We are hereby submitting our Technical and Financial Proposal, in a sealed envelope. We confirm that we have read the RFP Document in totality and abide by the terms and conditions stated in the document.

We acknowledge that we have

- Studied and analysed and satisfied ourselves about all the requirement of the tender including but not limited to market and market conditions
- Carefully assessed the commerciality of Project and that we will be fully responsible for all its assessment in this regard.
- Seen / visited / assessed the potential locations and fully understand and comprehend the technical, financial, commercial and investment requirements.

We have filled the complete information correctly in **Form 18**.

We hereby declare that all the information and statements made in this Proposal are true and accept that any misinterpretation contained in it may lead to our disqualification. Our Proposal is binding upon us.

We understand you are not bound to accept any Bid you receive.

Yours Sincerely,

Authorized Signature [In full and initials]:

Name and Title of Signatory:

Name and address of Firm:

Design, engineering, manufacture, supply, Installation, testing and commissioning of, 630KVA, 33KV/415V Compact Substation, Cabling and other accessories to be installed, its Integration with Existing NMRC SCADA at NMRC stations KP-II, Pari-Chowk.

17.1 Form 2: Firm Details

1.	Title and name of the Project: Design, engineering, manufacture, supply, Installation, testing and commissioning of, 630KVA, 33KV/415V Compact Substation, Cabling and other accessories to be installed, its Integration with Existing NMRC SCADA at NMRC stations KP-II, Pari Chowk.
2.	State the structure of the Bidder's organization (Bidders to complete/delete as appropriate) Sole Bidder
3.	For Bidders who are individual companies or firms, state the following: Name of Company or firm: Legal status: (e.g., incorporated private company, proprietorship, etc.) Registered address: Year of incorporation..... Principal place of business: Contact person: Contact person's title: Address, telephone, facsimile number and e-mail ID of contact person:
4.	JV & consortium not allowed.
5.	Employees Provident Fund No. (attach documentary proof) -
6.	Employees State Insurance Acts in India No. (attach documentary proof) -
7.	GST Registration No. (attach documentary proof) -
8.	PAN (attach documentary proof) -

Design, engineering, manufacture, supply, Installation, testing and commissioning of, 630KVA, 33KV/415V Compact Substation, Cabling and other accessories to be installed, its Integration with Existing NMRC SCADA at NMRC stations KP-II,Pari Chowk.

17.2 Form 3: Capability Statement

It is Compulsory for the bidder to fill this statement and the bidder must upload those document that support this statement

Tender Reference No : _____

Name of Work:_____

Name of Bidder: _____

S.No.	ELIGIBILITY CRITERIA	(To be filled by the Bidder)
1	Sole proprietorship, registered partnership firm, public limited company, private limited company can submit the Bid. The firms and the companies should be registered in India.	Yes/ No
2	<p>b. The Bidder should have a minimum experience of having satisfactorily completed similar works during last 7 (Seven) years period ending last day of month before the one in which the bids are invited should be either of the following:</p> <ul style="list-style-type: none"> i. One similar completed work costing not less than the amount equal to Rs. 5.69 Crore (Rupees Five Crore Sixty-Nine Lacs only) or ii. Two similar completed works each costing not less than the amount equal to Rs. 3.56 Crore (Rupees Three Crore and Fifty Six Lacs only) or iii. Three similar completed works each costing not less than the amount equal to Rs. 2.85 Crore (Rupees Two Crore Eighty Five Lacs only) 	7 Years

Design, engineering, manufacture, supply, Installation, testing and commissioning of, 630KVA, 33KV/415V Compact Substation, Cabling and other accessories to be installed, its Integration with Existing NMRC SCADA at NMRC stations KP-II,Pari Chowk.

S.No.	<u>ELIGIBILITY CRITERIA</u>	(To be filled by the Bidder)														
3	<p>The Bidder should have minimum average annual turnover $\geq 0.8X$ in the last 5 (Five) Financial Years (2018-19, 2019-20, 2020-21, 2021-22, 2022-23) preceding the Bid Due Date.</p> <table border="1" data-bbox="719 349 1158 824"> <tr> <td data-bbox="719 349 967 409">FY 18-19</td> <td data-bbox="967 349 1158 409"></td> </tr> <tr> <td data-bbox="719 409 967 470">FY 19-20</td> <td data-bbox="967 409 1158 470"></td> </tr> <tr> <td data-bbox="719 470 967 530">FY 20-21</td> <td data-bbox="967 470 1158 530"></td> </tr> <tr> <td data-bbox="719 530 967 591">FY 21-22</td> <td data-bbox="967 530 1158 591"></td> </tr> <tr> <td data-bbox="719 591 967 651">FY 22-23</td> <td data-bbox="967 591 1158 651"></td> </tr> <tr> <td data-bbox="719 651 967 712">Total Turnover</td> <td data-bbox="967 651 1158 712"></td> </tr> <tr> <td data-bbox="719 712 967 824"><u>Average Turn-over</u></td> <td data-bbox="967 712 1158 824"></td> </tr> </table>	FY 18-19		FY 19-20		FY 20-21		FY 21-22		FY 22-23		Total Turnover		<u>Average Turn-over</u>		
FY 18-19																
FY 19-20																
FY 20-21																
FY 21-22																
FY 22-23																
Total Turnover																
<u>Average Turn-over</u>																
4	The Bidder should have Positive Profit before Tax in 2 (Two) years out of last 5, Financial Years (2018-19, 2019-20, 2020-21, 2021-22, 2022-23)															
5	Liquidity Working capital/Net cash flow (Current Asset minus Current Liabilities) should be $\geq X/7$ in the last audited financial year.															
6	Net Worth: Net worth should be $\geq X/5$ in the last audited financial year.															
7	The Bidder must have either the Registered Office or the functional Branch Office located in Delhi NCR, Noida, and Greater Noida.															
8	The Bidder should be registered with the Goods and Services Tax Authorities.															
9	The Bidder should not have been blacklisted/ banned/ declared ineligible for corrupt and fraudulent practices by the Government of India/ any State Government/ Government Agency and Supreme court and contracts have been terminated/ foreclosed by any company / department due to non-fulfillment of Contractual obligation in last 5 (five) financial years.															

Note:

For Value of X please refer section: 4 clause 4.1 of the RFP.

Design, engineering, manufacture, supply, Installation, testing and commissioning of, 630KVA, 33KV/415V Compact Substation, Cabling and other accessories to be installed, its Integration with Existing NMRC SCADA at NMRC stations KP-II, Pari-Chowk.

17.3 Form 4: Work Experience

The following format shall be used for statement of experience of Bidder:

SN	Similar Contract description	Contract Identification Number	Award date & Completion date	Employer's Name, address, telephone number, e-mail etc	Role in contract		If in Consortium then % participation	Completion cost	Value of similar work in completed work
					Individual	Consortium			
1									
2									
3									
4									
Add required number of rows									

Authorized signatory

Name:

Date:

Name of the Bidder with seal

NOTE:

1. Only the value of contract as executed by the applicant/member in his own name should be indicated. Where a work is undertaken by a group, only that portion of the contract which is undertaken by the concerned applicant/member should be indicated and the remaining done by the other members of the group be excluded. This is to be substantiated with documentary evidence
2. The Bidder shall upload details of work executed by them in the prescribed format for the works to be considered for qualification of work experience criteria. Documentary proof such as completion certificates from the client clearly indicating the nature/scope of work, actual completion cost and actual date of completion for such work should be uploaded. In case work is executed for private client documentary proof such as copy of work order, Bill of quantities, Bill wise details of payment received certified by CA, TDS certificates for all the payments received, copy of final/ last bill paid by the client should be uploaded. The offers submitted without this documentary proof will not be evaluated.
3. Value of successfully completed portion of any ongoing work up to the last day of the previous month of tender submission will also be considered for qualification of work experience criteria.
4. For completed works, value of work done shall be updated to the last day of the previous month of tender submission price level assuming 5% inflation for Indian Rupees every year and 2% for foreign currency portions per year. The exchange rate of foreign currency shall be applicable 28 days before the submission date of tender.
5. If the above work(s) comprise(s) other works also, then client's certificate clearly indicating the amount of work done in respect of the "similar work" shall be furnished by the Bidder in support of work experience along-with their tender submissions.

Design, engineering, manufacture, supply, Installation, testing and commissioning of, 630KVA, 33KV/415V Compact Substation, Cabling and other accessories to be installed, its Integration with Existing NMRC SCADA at NMRC stations KP-II, Pari-Chowk.

17.4 Form 5: Financial Capability Details

Bidder should submit their financial details as per the following:

This is to certify that the details of M/s _____ having registered office at _____, as applicable, is as below:

A.

S.No.	Financial year	Name of the Bidder	Turnover from Work
1	FY 18=19		
2	FY 19-20		
3.	FY 20-21		
4.	FY 21-22		
5.	FY 22-23		
	Average Annual Turn-over		

B.

S.No.	Financial year	Name of the Bidder	Profitability
1	FY 18=19		
2	FY 19-20		
3.	FY 20-21		
4.	FY 21-22		
5.	FY 22-23		

C.

S. No.	Financial Year	Name of the Bidder	Liquidity

D.

S. No.	Financial Year	Name of the Bidder	Net Worth

Certificate of the Chartered Accountants/Statutory Auditors

Based on Audited Accounts and other relevant documents of _____ (Name of Bidder), we M/s _____, Chartered Accountants/ Statutory Auditors, certify that the above information pertaining to **(2018-19, 2019-20, 2020-21, 2021-22, 2022-23)** is correct.

Design, engineering, manufacture, supply, Installation, testing and commissioning of, 630KVA, 33KV/415V Compact Substation, Cabling and other accessories to be installed, its Integration with Existing NMRC SCADA at NMRC stations KP-II,Pari Chowk.

Signature and Seal of
Chartered Accountants/Statutory Auditors
(with membership no. & UIDN No.)

Authorised Signatory

(Name & Designation of Authorised Signatory)

In case the Financial Statements for the latest financial year are not audited and therefore the Bidder cannot make it available, the Bidder shall give an undertaking to this effect and the statutory auditor/chartered accountant shall certify the same. In such a case, the Bidder shall provide the Audited Financial Statements for 4 (Four) years preceding the year for which the Audited Financial Statement is not being provided. Also, pertaining to latest financial year, the bidder shall submit an affidavit certifying that "The Annual Accounts have not been audited so far we are submitting the CA certified provisional accounts which shall be substantiated by the Audited Accounts, when prepared."

NOTE:

1. All such documents reflect the financial data of the bidder and not that of sister or parent company.
2. The financial data in above prescribed format shall be certified by CA/ Company Auditor under his signature and stamp in original along with membership no and UDIN.
3. The Bidder shall provide the audited annual financial statements as required.

Design, engineering, manufacture, supply, Installation, testing and commissioning of, 630KVA, 33KV/415V Compact Substation, Cabling and other accessories to be installed, its Integration with Existing NMRC SCADA at NMRC stations KP-II, Pari-Chowk.

17.5 Form 6: Memorandum

Name of Work: Design, engineering, manufacture, supply, Installation, testing and commissioning of, 630KVA, 33KV/415V Compact Substation, Cabling and other accessories to be installed, its Integration with Existing NMRC SCADA at NMRC stations KP-II, Pari Chowk.

I/We agree to keep the quoted rate open for acceptance for 180 days from the due date of submission thereof and not make any modification in its terms and conditions.

I/We hereby declare that I/We shall treat the quotation documents, drawings and other records connected with the works as secret/ confidential documents and shall not communicate information derived there from to any person other than the information in any manner prejudicial to the safety of NMRC.

Signature of the bidder with seal
Dated:

Design, engineering, manufacture, supply, Installation, testing and commissioning of, 630KVA, 33KV/415V Compact Substation, Cabling and other accessories to be installed, its Integration with Existing NMRC SCADA at NMRC stations KP-II,Pari Chowk.

17.6 Form 7: Undertaking

I confirm that we (Bidder, including any member in case of Consortium), _____

- a. Have not been banned /declared ineligible for corrupt and fraudulent practices by any government/government-undertaking/ semi-government/ govt.-controlled institutions, any court of law having jurisdiction in India for the past 5 (five) years.
- b. Do not have any pending litigation & non-performing contracts during last 5 (five) years. Further, has not been barred by any government/government-undertaking/ semi-government/ govt.-controlled institutions
- c. Have not abandoned any work in last 5 (five) years.
- d. Have not delayed in similar work completion during orders executed in last 5 (five) years.
- e. Do not ever been terminated due to poor performance.
- f. Have not suffered Bankruptcy/ insolvency in last 5 (five) years.
- g. Have not been blacklisted/debarred by any organization.
- h. Have not been be involved in any illegal activity and/or has not been charge sheeted for any criminal act during the last 5 (five) years.
- i. Have not submitted any misleading information in the Bid.
- j. Are financially sound to perform the work.

Authorized signatory

Name:

Date:

Name of the Bidder with seal

Design, engineering, manufacture, supply, Installation, testing and commissioning of, 630KVA, 33KV/415V Compact Substation, Cabling and other accessories to be installed, its Integration with Existing NMRC SCADA at NMRC stations KP-II,Pari Chowk.

17.7 Form 8: Power of Attorney

(To be on non-judicial stamp paper of appropriate value as per Stamp Act relevant to place of execution.)

Power of Attorney to be provided by the Bidding Company in favour of its representative as evidence of authorized signatory's authority.

Know all men by these presents, We(name and address of the registered office of the Bidding Company) do hereby constitute, appoint and authorize Mr./Ms.....(name and residential address) who is presently employed with us and holding the position of , as our Attorney to do in our name and our behalf all or any of the acts, deeds or things necessary or incidental to submission of our Bid for **Design, engineering, manufacture, supply, Installation, testing and commissioning of, 1000KVA, 33KV/415V Compact Substation, Cabling and other accessories to be installed at NMRC station sector-51, Noida** in response to the RFP Document dated

issued by Noida Metro Rail Corporation Ltd. ("NMRC" or "the Corporation"), including signing and submission of the Bid and all other documents related to the Bid, including but not limited to undertakings, letters, certificates, acceptances, clarifications, guarantees or any other document which the Corporation may require us to submit. The aforesaid Attorney is further authorized for making representations to the NMRC or any other authority, and providing information / responses to the NMRC, representing us in all matters before the NMRC, and generally dealing with the Corporation in all matters in connection with our Bid till the completion of the bidding process as per the terms of the RFP Document and further till the Contract is entered into with the NMRC and thereafter till the expiry of the Contract.

We hereby agree to ratify all acts, deeds and things done by our said attorney pursuant to this Power of Attorney and that all acts, deeds and things done by our aforesaid attorney shall be binding on us and shall always be deemed to have been done by us.

All the terms used herein but not defined shall have the meaning ascribed to such terms under the RFP Document.

Signed by the within named

.....[Insert the name of the executant company]

through the hand of

Mr.

duly authorized by the Board to issue such Power of Attorney Dated this

..... day of

Accepted

.....

Signature of Attorney

(Name, designation and address of the Attorney)

Design, engineering, manufacture, supply, Installation, testing and commissioning of, 630KVA, 33KV/415V Compact Substation, Cabling and other accessories to be installed, its Integration with Existing NMRC SCADA at NMRC stations KP-II,Pari Chowk.

Attested

(Signature of the executant)

(Name, designation and address of the executant)

Signature and stamp of Notary of the place of execution

Common seal of has been affixed in my/our presence pursuant to Board of Director's Resolution dated.....

WITNESS

1.

(Signature)

Name

Designation.....

2.

(Signature)

Name

Designation.....

Notes:

1. The mode of execution of the power of attorney should be in accordance with the procedure, if any, laid down by the applicable law and the charter documents of the executant(s) and the same should be under common seal of the executants affixed in accordance with the applicable procedure. Further, the person whose signatures are to be provided on the power of attorney shall be duly authorized by the executant(s) in this regard.
2. In the event, power of attorney has been executed outside India, the same needs to be duly notarized by a notary public of the jurisdiction where it is executed.
3. Also, wherever required, the executant(s) should submit for verification the extract of the charter documents and documents such as a board resolution / power of attorney, in favour of the person executing this power of attorney for delegation of power hereunder on behalf of the executant(s).

Design, engineering, manufacture, supply, Installation, testing and commissioning of, 630KVA, 33KV/415V Compact Substation, Cabling and other accessories to be installed, its Integration with Existing NMRC SCADA at NMRC stations KP-II, Pari-Chowk.

17.8 Form 9: Saleable Form for Tender Document

Job No.

The required fee of tender form has been deposited in _____ Bank A/c No. _____ RTGS/NEFT and the scanned copy of UTR receipt with Transaction Id is being enclosed with E-tender documents. If the copy of UTR receipt is not uploaded with the E-tender the tender shall be rejected.

DETAILS OF EARNEST MONEY ATTACHED

The required amount of Earnest money has been deposited in _____ Bank A/c No. _____ RTGS/NEFT and the scanned copy of UTR receipt with transaction Id is being enclosed with E-tender documents. If the copy of UTR receipt is not uploaded with the E-tender the tender shall be rejected.

Signature of BIDDER

Design, engineering, manufacture, supply, Installation, testing and commissioning of, 630KVA, 33KV/415V Compact Substation, Cabling and other accessories to be installed, its Integration with Existing NMRC SCADA at NMRC stations KP-II, Pari-Chowk.

17.10 Form 11: Undertaking pertaining to Personnel

- We confirm to deploy Project Personnel required to achieve progress of work as per approved construction of work program and conditions mentioned in the tender document.
- We confirm to deploy man power requirement of SHE Organization as required under Conditions of contract on Safety and Health for electrical works and confirm to deploy man power over and above the minimum numbers, if the work requires.
- The contractor shall deploy resources as per the mentioned minimum requirement in the tender and confirm to deploy manpower over and above the minimum numbers indicated above, if the work requires so.
- These minimum resources are as per the requirements of the various activities at different stages of works. All resources need not to be mobilised simultaneously, resources as per the requirement of various stages of works shall be mobilised in accordance with the instructions of the Engineer. The decision of the Engineer shall be final and bonding.
- The performance of project personal deployed will be evaluated periodically by Employer during the contract period. In case the performance of any of the personnel is not satisfactory, the contractor shall replace them with good personnel immediately as per the directions of the Engineer.

Date:

Signature with Stamp/Seal

Design, engineering, manufacture, supply, Installation, testing and commissioning of, 630KVA, 33KV/415V Compact Substation, Cabling and other accessories to be installed, its Integration with Existing NMRC SCADA at NMRC stations KP-II, Pari-Chowk.

17.11 Form 12: Resources proposed for the O&M - Plant & Equipment

1. We hereby confirm to deploy the minimum resources as per mentioned minimum requirement in the tender document.
2. We confirm to deploy resources as per the requirement and also confirm to deploy plants & equipments over and above the minimum numbers, if the work requires so.
3. Hiring of Cranes shall be as per approved by Engineer-in-Charge. Third party certification of cranes, competency certification of the operators etc. would be required before grant of approval.

Date:

Signature with Stamp/Seal

Design, engineering, manufacture, supply, Installation, testing and commissioning of, 630KVA, 33KV/415V Compact Substation, Cabling and other accessories to be installed, its Integration with Existing NMRC SCADA at NMRC stations KP-II, Pari-Chowk.

17.12 Form 13: Bid Capacity Information

Name and brief particulars of contract (Clearly indicate the part of the work assigned to the applicants)	Name of client with telephone number and fax number	Contract Value In Rupees Equivalent (Give only the value of work assigned to the applicant(s))	Value of balance work yet to be done in Rupee equivalent as on last day of the previous month of tender submission	Date of Completion as per Contract Agreement	Expected of Completion to Date	Delay if any, with reason next	Value work Done during 4 months with effect from the first day of the month of tender submission
Total							

Bid Capacity (Bidder shall calculate, mention his bid capacity **and enclose the supporting calculation**)

A = Rs.

N = years

B = Rs.

Assessed available bid capacity = $2 * A * N - B$

= Rs.

S.No.	Financial year	Total Value of Works done as per audited financial statements
1	FY 2018-19	
2	FY 2019-20	
3	FY 2020-21	
4	FY 2021-22	
5	FY 2022-23	

Certificate of the Chartered Accountants / Company Auditor

We, M/s _____, Chartered Accountants/ Company Auditors, certify that the above information is correct.

Name of Chartered Accountants / Company Auditor

Signature and Seal of Chartered Accountants/ Company Auditor

Membership Number & UDIN No. of Chartered Accountants/ Company Auditor

Authorised Signatory

(Name & Designation of Authorised Signatory)

Design, engineering, manufacture, supply, Installation, testing and commissioning of, 630KVA, 33KV/415V Compact Substation, Cabling and other accessories to be installed, its Integration with Existing NMRC SCADA at NMRC stations KP-II,Pari Chowk.

NOTE:

The financial data in above prescribed format shall be certified by Chartered Accountant/ Company Auditor in original under his signature & stamp along with audited financial statements with UDIN.

Value of existing commitments for on-going works during period of 8 months w.e.f. from the first day of the month of tender submission has to be uploaded by the tenderer in Form. These data shall be certified by the Chartered Accountant with his stamp and signature in original with membership number and UDIN.

**Design, engineering, manufacture, supply, Installation, testing and commissioning of, 630KVA, 33KV/415V Compact Substation, Cabling and other accessories to be installed, its Integration with Existing NMRC SCADA at NMRC stations KP-II,Pari Chowk.
17.13 Form 14: Proposed Personnel**



NAME :

EMPLOYEE ID. :

FATHER'S NAME :

DATE OF BIRTH :

PERMANENT ADDRESS :

.....

RESIDENTIAL ADDRESS :

.....

MARITAL STATUS :

EDUCATIONAL QUALIFICATION :

TECHNICAL QUALIFICATION :

EXPERIENCE :

LANGUAGE KNOWN :

NATIONALITY :

CATEGORY :

DATE:

PLACE:



SIGNATURE

(To be filled by contractor)

Attested by authorised person:

Note: A staffing schedule containing the names, qualifications, professional experience and corporate affiliation of all proposed management personnel (above the level of shift supervisor) and specialists for this work. The submission shall include a provisional management structure and organisation chart showing areas of responsibility, relative seniorities and lines of reporting. The proposed staffing plan shall be in conformity with the "Clause 4.3 – Personnel" of tender document

Design, engineering, manufacture, supply, Installation, testing and commissioning of, 630KVA, 33KV/415V Compact Substation, Cabling and other accessories to be installed, its Integration with Existing NMRC SCADA at NMRC stations KP-II,Pari Chowk.

17.14 Form 15: Obligation/ Compliance to be ensured by Contractor

Sl. No.	Items	Compliance of Contractor (To be filled by contractor)	
		Yes	No
1	License for employing contract labour		
2	Compliance of minimum wages Act by payment of wage on 7th of every month through Bank or in the presence of nominated representative of employer (NMRC Supervisor/manager)		
3 (a)	Compliance of provision of ESI & EPF Act		
3 (b)	Ensure treatment in ESI hospital in case of accident/injuries suffered in performance of work and compensation under ESI Act.		
4	Send Accident report to Regional Labour Commissioner (RLC) & ESI authorities.		
5	Observance of working hours, weekly rest and overtime payments as per minimum wages Act-1948.		

Note: - A Non- filling or "No" by contractor will lead to non-eligibility for contractor in further tendering process.

S.N	Description	Reference Clause	Requirement
i	Latest "date for commencement" of the Works	Clause 8.1 of the GCC	Date given in NOA or Employer's Notice to Proceed
ii	Liquidated Damages	Clause 8.5 of the GCC	(i) 0.015% of contract price per day of delay in completion of whole work. (ii) Total maximum limit of LD including sums payable by the employer to designated contractors is 15% as mentioned in GCC.
iii	Insurance for workers/ employees	Clause 15.4 of the GCC	All the contractor's employees shall have to be covered under ESI and ECA as per Special conditions of contract.
iv	Insurance cover for Contractor's All Risk and other requirements as specified in the GCC	Clause 15 of the GCC	100% of the Total Contract Price.
v	Amount of Third-Party Insurance	Clause 15.3 of the GCC	INR 0.75 Million for any one incident, with no. of incidents unlimited.
vi	Period in which all insurances have to be effected	Clause 15.5 of the GCC	Within 1 week from the "date of commencement"

Signature of authorized signatory of Bidder

Design, engineering, manufacture, supply, Installation, testing and commissioning of, 630KVA, 33KV/415V Compact Substation, Cabling and other accessories to be installed, its Integration with Existing NMRC SCADA at NMRC stations KP-II, Pari-Chowk.

17.15 Form 16: Performa for Clarifications / Amendments on the RFP

Sl. No.	Document	Clause No. and Existing Provision	Clarification required	Suggested Text for the Amendment	Rationale for the Clarification or Amendment

Authorized signatory

Name:

Date:

Name of the Bidder with seal

**Design, engineering, manufacture, supply, Installation, testing and commissioning of, 630KVA, 33KV/415V Compact Substation, Cabling and other accessories to be installed, its Integration with Existing NMRC SCADA at NMRC stations KP-II, Pari-Chowk.
17.16 Form 17: Bid Offer/ BOQ (Format)**

To

ED

Noida Metro Rail Corporation (NMRC) Limited
Block-III, 3rd Floor, Ganga Shopping Complex
Noida -201301,
District Gautam Budh Nagar, Uttar Pradesh

THIS FORM IS NOT TO BE FILLED. THE BIDDERS ARE REQUIRED TO FILL THE FINANCIAL PROPOSAL IN XLS FORMAT AFTER DOWNLOADING THE FORM FROM THE E-PROCUREMENT WEBSITE FOR THIS TENDER DOCUMENT

Sub: Design, engineering, manufacture, supply, Installation, testing and commissioning of, 630KVA, 33KV/415V Compact Substation, Cabling and other accessories to be installed, its Integration with Existing NMRC SCADA at NMRC stations KP-II, Pari Chowk.

Dear Sir,

I/we have read and examined the RFP document, general terms and conditions.

I/we hereby quote for the Total Price for Design, engineering, manufacture, supply, Installation, testing and commissioning of, 630KVA, 33KV/415V Compact Substation, Cabling and other accessories to be installed at NMRC station sector-51, Noida.

S. No.	Description	Total Amount	Amount in Words
1	Estimated value of work	Rs. 7,10,23,213.85 (including GST)	(Rupees Seven Crore Ten Lacs Twenty Three Thousands Two Hundred Thirteen and eighty Five paise only)

S.N.	Quoted amount (Rs.)	
1	In words	
	In figures	
2	Rebate in % (percentage) if any	
	In words	
	In figures	

Design, engineering, manufacture, supply, Installation, testing and commissioning of, 630KVA, 33KV/415V Compact Substation, Cabling and other accessories to be installed, its Integration with Existing NMRC SCADA at NMRC stations KP-II, Pari-Chowk.

Price Schedule

(It is to be noted that BOQ corresponds to Section-6 Technical Specifications of Tender Document)

(This BOQ template must not be modified/ replaced by the bidder and the same should be uploaded after filling the relevant columns, else the bidder is liable to be rejected for this tender. Bidders are allowed to enter the Bidder Name and Values only)

S. N.	Description of Items	Unit	Qty.	Rate	Amount
	COMPACT SUBSTATION:				
1	Design, engineering, manufacture, supply, installation, testing & commissioning of Fully Type tested as per relevant standard, Outdoor, Plinth Mounted, Compact Substation of 33KV/415 Volts, equipped with Al dry type 630 KVA Cast Resin Transformer 3 way 33 KV Ring Main Unit consisting of 3 Nos. 33 KV SF6 Insulated Vacuum Circuit Breaker(630A 25kA for 3sec),HT Metering in transformer feeder (CT,PT & Energy Meter as per PVVNL specifications),RTU/RIO & with LT Air Circuit Breaker, MCCB & LT Metering arrangement as secondary side complete as per standard & technical data sheet. It includes Design, Engineering, supply ,installation, testing & Commissioning of Cable Differential Relay, Clean Agent based Gas flooding system, Auxiliary AC/DC supply, Compact substation Protection grading with existing NMRC ring network & any other component or material required to make the installation complete & operable.	SET.	2	17500000	3,50,00,000
2	Supply, Installation Testing & Commissioning of outdoor LT Panel as per IEC-61439 standard of following specification: Incomer 1no. 160A,415V,Isc=25kA TPN MCCB and with variable overcurrent and short circuit releases & each component with- i. 3nos. Cast resin current transformer of 160/5 ratio 15VA burden with Ammeter & Ammeter Selector Switch ii. 1 Set of (0-500V) digital voltmeter with selector switch with 2 amps MCB iii. 1 set Red/Green ON/OFF indicating lamps iv 1 set of three phase (red, yellow, blue) indicating lamp v Amber healthy trip indicating lamps Busbar Electrolytic high conductivity Copper three phase and neutral busbar rated at 160A as per specification with heat shrinkable insulation sleeves suitable to withstand symmetrical fault level of 25kA at 415V.The neutral busbar is to be of same size as phases. Outgoing i. 3nos. 63A, 415V,Isc=25kA TPN MCCB and with variable overcurrent & short circuit releases & each having indication lamps to give status. ii. 3nos. 32A,415V,Isc=25kA, TPN MCCB and with variable overcurrent & short circuit releases	Nos.	2	5,00,000	10,00,000

Design, engineering, manufacture, supply, Installation, testing and commissioning of, 630KVA, 33KV/415V Compact Substation, Cabling and other accessories to be installed, its Integration with Existing NMRC SCADA at NMRC stations KP-II,Pari Chowk.

	& each having indication lamp to give status. The switchboard shall be completed with all inter connections, risers, internal wiring, labels etc complete as required.				
	Cabling				
3.1	Supply of 1Cx300 Sq mm AL, Armoured, XLPE, FRLS power cable of 33 KV grade as per relevant standard & technical data sheet	Rmt.	1800	1375	2475000
3.1.1	Installation, Testing (as per standard Norms such as Hi -POT, Meggar etc. on site)& commissioning of one circuit (3 Run) Armoured, FRLS, XLPE power cable of 33 KV grade of following size direct in ground(HDPE pipe of suitable size in case of Road crossing) including excavation, sand cushioning, protective covering, warning tape, refilling the trench, restoration ofTile/Marble, road etc as required. Upto 300 sq. mm.	Rmt.	120	1650	198000
3.1.2	Installation ,Testing (as per standard Norms such as Hi -POT, Meggar etc. on site) & commissioning of one circuit (3 Run) Armoured FRLS XLPE power cable of 33 KV grade of followingsize from Metro Viaduct/ASS to ground level. Upto 300sq.mm	Rmt.	480	1155	554400
3.2	Supply of 4 Core 95Sq.mm Al armoured XLPE insulated FRLS cable of 1.1kV grade as per relevant standard & technical data sheet	Rmt.	200	750	150000
3.2.1	Installation ,Testing & commissioning of 4 Core 95 sq.mm Al armoured, FRLS, XLPE power cable of 1.1 KV grade direct in ground(HDPE pipe of suitable size in case of Road crossing) including excavation, sand cushioning, protective covering, warning tape, refilling the trench, restoration of Tile/Marble, road etc as required.	Rmt.	200	120	24000
3.3	Supply of 4 Core Single Mode Optical Fiber Cable	Rmt.	300	150	45000
3.3.1	Installation ,Testing (as per standard) & commissioning of 4 Core Single Mode Optical Fiber cable required for Cable differential protection in HDPE pipe of suitable size including Splic Joints, termination, junction box & any other component required to make the installation complete & operable.	Rmt.	300	125	37500
3.4	Supply of 6 Core Multi Mode Optical Fiber Cable	Rmt.	100	150	15000
3.4.1	Installation ,Testing (as per standard) & commissioning of 6 Core Multi Mode Optical Fiber cable required for SCADA connectivity in HDPE pipe of suitable size including Splic Joints, termination, junction box & any other component required to make the installation complete & operable.	Rmt.	100	120	12000
3.4.2	Providing and fixing 50 mm x 6 mm GI strip on surface or in recess for connection etc. as required.	Meters	200	350	70000
5	Cable Tray				
5.1	Supply & fixing of pre-galvanized factory fabricated GI ladder type cable trays with radial bends, supports of following size as per specification Runners 20x75x20x2.5mm	Meters	60	900	54000

Design, engineering, manufacture, supply, Installation, testing and commissioning of, 630KVA, 33KV/415V Compact Substation, Cabling and other accessories to be installed, its Integration with Existing NMRC SCADA at NMRC stations KP-II,Pari Chowk.

	Rungs 20x30x20x2.5 mm 250mm Center to Center (C/C) Suspenders 25x25x4mm angle 1800mm Center to Center (C/C) 450mm wide				
5.2	Supply & fixing of pre-galvanized factory fabricated one side covered with appropriate size of GI sheet GI ladder type cable trays with radial bends, supports of following size as per specification Runners 20x75x20x2.5mm Rungs 20x30x20x2.5 mm 250mm Center to Center (C/C) Suspenders 25x25x4mm angle 1800mm Center to Center (C/C) 450mm wide	Meters	40	1300	52000
6	Cable Termination				
6.1	Supply, installation and testing of GIS termination kit suitable for single core 300 Sq mm AL, Armoured, XLPE, FRLS power cable of 33 KV grade. Make (Raychem, 3M or eq.)	Nos.	3	95000	285000
6.2	Supply, installation and testing of Termination kit suitable for single core 300 Sq mm AL, Armoured, XLPE, FRLS power cable of 33 KV grade for Compact Sub-station.	Nos.	12	25000	300000
7	Cable Joint				
7.1	Supply & installation of straight through joint kit suitable for single core 300 Sq mm AL,XLPE, FRLS power cable of 33 KV grade. Make (Raychem, 3M or eq.)	Nos.	12	42000	504000
8	Integration & Testing				
8.1	Integration of Compact Substation with existing NMRC Siemens make (VICOS) SCADA and its Monitoring & Control from NMRC Operational Control Center (OCC) & Backup Control Center (BCC) including any other component or material required to make the installation complete & operable. Note:- i) Bidder is requested to visit corridor stations & existing installations to meet the operational requirements. ii) Letter from M/s Siemens to extend the support for this work need to be provided.	Sets	2	11000000	2,20,00,000
8.2	Testing of all Compact substation signals & controls as per technical details with NMRC OCC & BCC	Sets	2	100000	200000
9	DLP Cum Comprehensive Annual Maintenance of above compact substations and other associated work as mentioned in the BOQ with round the clock (24x7) one experienced technician having the knowledge of compact substation or 33 KV or above substation operation, fault detection, rectification etc. (All labour laws and minimum wages as per central government etc is mandatory)		0		
9.1	DLP cum Comprehensive Annual Maintenance Charges for Year 1	Sets	1	1914285.71	1914285.71
9.2	DLP cum Comprehensive Annual Maintenance Charges for Year 2	Sets	1	1942857.14	1942857.14

Design, engineering, manufacture, supply, Installation, testing and commissioning of, 630KVA, 33KV/415V Compact Substation, Cabling and other accessories to be installed, its Integration with Existing NMRC SCADA at NMRC stations KP-II,Pari Chowk.

10	Spare				
10.1	Straight through joint kit suitable for single core 300 Sq mm AL, XLPE,FRLS power cable of 33 KV grade. Make (Raychem, 3M or eq.)	Nos.	2	25000	50000
10.2	Termination kit suitable for single core 300 Sq mm AL,Armoured, XLPE, FRLS power cable of 33 KV grade.	Nos.	1	15000	15000
10.3	33kV Surge Arrester	Nos.	2	50000	100000
10.4	Vacuum Bottle suitable for 630A,33kV,25kA for 3sec Vacuum Circuit Breaker	Nos.	1	50000	50000
11	Tools				
11.1	Earth Resistance Meter (DET4TR2 or Equivalent)	Nos.	1	245000	245000
11.2	Multimeter (AVO410 or Equivalent)	Nos.	1	18500	18500
11.3	Clamp Multimeter (DCM 340 or Equivalent)	Nos.	1	24000	24000
11.4	High Voltage non-contact proximity detectors from 240 V to 132 KV	Nos.	1	40000	40000
11.5	Portable Power Quality Analyser	Nos.	1	350000	350000
12	Earthing with G.I. earth plate 600 mm X 600 mm X 6 mm thick including accessories, and providing masonry enclosure with cover plate having locking arrangement and watering pipe of 2.7 metre long etc. with charcoal/ coke and salt as required.	Nos.	6	7472	44832
	Civil Work				
13	"Providing and laying in position cement concrete of specified grade excluding the cost of centering and shuttering - All work up to plinth level :"				
	1:3:6 (1 Cement : 3 coarse sand (zone-III) derived from natural sources : 6 graded stone aggregate 20 mm nominal size derived from natural sources)	cum	85	7294.7	620049.50
14	Providing and laying in position ready mixed or site batched design mix cement concrete for reinforced cement concrete work; using coarse aggregate and fine aggregate derived from natural sources, Portland Pozzolana / Ordinary Portland /Portland Slag cement, admixtures in recommended proportions as per IS: 9103 to accelerate / retard setting of concrete, to improve durability and workability without impairing strength; including pumping of concrete to site of laying,curing, carriage for all leads; but excluding the cost of centering, shuttering, finishing and reinforcement as per direction of the engineer-in-charge; for the following grades of concrete.				
15	Concrete of M25 grade with minimum cement content of 330 kg /cum	cum	55	9504.75	522761.25
16	Steel reinforcement for R.C.C. work including straightening, cutting, bending, placing in position and binding all complete upto plinth level.				
17	Thermo-Mechanically Treated bars of grade Fe-500D or more.	kg	1500	107.85	161775

Design, engineering, manufacture, supply, Installation, testing and commissioning of, 630KVA, 33KV/415V Compact Substation, Cabling and other accessories to be installed, its Integration with Existing NMRC SCADA at NMRC stations KP-II,Pari Chowk.

18	Providing and fixing G.I. chain link fabric fencing of required width in mesh size 50x50 mm including strengthening with 2 mm dia wire or nuts, bolts and washers as required complete as per the direction of Engineer-in-charge. Made of G.I. wire of dia. 4 mm, PVC coated to achieve outer dia not less than 5 mm in required colour and shade	sqm	180	1067.1	192078
19	Brick work with common burnt clay F.P.S. (non modular) bricks of class designation 7.5 in foundation and plinth in:				
20	Cement mortar 1:4 (1 cement : 4 coarse sand)	cum	35	7370.65	257972.75
	12 mm cement plaster of mix :1:4 (1 cement: 4 fine sand)	sqm	100	347.05	34705
22	Earth work in excavation by mechanical means (Hydraulic excavator)/ manual means over areas (exceeding 30 cm in depth, 1.5 m in width as well as 10 sqm on plan) including getting out and disposal of excavated earth lead upto 50 m and lift upto 1.5 m, as directed by Engineer-in-charge.				
	All kinds of soil	cum	50	177.5	8875
23	Surface dressing of the ground including removing vegetation and inequalities not exceeding 15 cm deep and disposal of rubbish, lead up to 50 m and lift up to 1.5 m. All kinds of soil	sqm	200	34.15	6830
24	Disposal of building rubbish / malba / similar unserviceable, dismantled or waste materials by mechanical means, including loading, transporting, unloading to approved municipal dumping ground or as approved by Engineer-in-charge, beyond 50 m initial lead, for all leads including all lifts involved.	cum	150	263.95	39592.50
25	Steel work welded in built up sections/ framed work, including cutting, hoisting, fixing in position and applying a priming coat of approved steel primer using structural steel etc. as required.				
26	In gratings, frames, guard bar, ladder, railings, brackets, gates and similar works	kg	7000	172.6	1208200
27	Any other latest DSR for electrical Items and CIVIL			200000	200000
	TOTAL (In Rs.)				7,10,23,213.85

Design, engineering, manufacture, supply, Installation, testing and commissioning of, 630KVA, 33KV/415V Compact Substation, Cabling and other accessories to be installed, its Integration with Existing NMRC SCADA at NMRC stations KP-II, Pari-Chowk.

Please Note:

The Bidder with the lowest quoted cost for **Design, engineering, manufacture, supply, Installation, testing and commissioning of, Design, engineering, manufacture, supply, Installation, testing and commissioning of, 630KVA, 33KV/415V Compact Substation, Cabling and other accessories to be installed, its Integration with Existing NMRC SCADA at NMRC stations KP-II, Pari-Chowk** in the financial quote (L1 bidder) shall be selected for the award of contract.

- a. The Bidder shall be required to quote the percentage in the BOQ.
- b. It will be deemed to include all Taxes including GST, Duties, Octroi, Royalty etc., cost of all plants, labour, supervision, materials, transport, all temporary works, erection, maintenance, utility identification, contractor's profit and establishment/ overheads, together with preparation of design and drawings, all general risks, insurance liabilities, compliance of labour laws and obligations set out or implied in the contracts.
- c. The work executed against the BOQ items in would be paid on measurement basis.
- d. The Financial Bid submitted is unconditional and fulfils all the requirements of the TOR Document.
- e. We have completely read and understood the Bid Document. The Financial Tender submitted is unconditional and fulfils all the requirements of the Tender Document.
- f. Our Financial Proposal shall be binding upon us subject to the modifications resulting from contract negotiations, up to expiration of the validity period of the Proposal. We understand you are not bound to accept any Proposal you receive.

Signature and Name of the Authorized Person

NAME OF THE BIDDER AND SEAL

Design, engineering, manufacture, supply, Installation, testing and commissioning of, 630KVA, 33KV/415V Compact Substation, Cabling and other accessories to be installed, its Integration with Existing NMRC SCADA at NMRC stations KP-II, Pari-Chowk.

17.17 Form 18: Bid Details

The following list is intended to help the Bidders in submitting offer which are complete. An incomplete offer is liable to be rejected. Bidders are advised to go through the list carefully and take necessary action.

S. No.	Particulars	Attached Yes / No / Not Applicable	Page no. (Mandatory)
1	Bid Processing Fees		
2	Earnest Money Deposit		
3	Form 1: Letter of Proposal Submission		
4	Form 2: Firm Details		
5	Form 3: Capability Statement		
6	Form 4: Work Experience		
7	Form 5: Financial Capability Details		
8	Form 6: Memorandum		
9	Form 7: Undertaking		
10	Form 7: Undertaking Power of Attorney		
11	Form 9: Saleable Form for Tender Document		
12	Form 10: Declaration of Refund of Earnest Money		
13	Form 11: Undertaking pertaining to Personnel		
14	Form 12: Resources proposed for the O&M - Plant & Equipment		
15	Form 13: Bid Capacity Information		
16	Form 14: Proposed Personnel		
17	Form 15: Obligation/ Compliance to be ensured by Contractor		
18	Form 16: Performa for Clarifications / Amendments on the RFP		
19	Statutory proof of existence as the legal entity		
20	PAN certificate as per legal entity		
21	A copy of the Audited balance sheets and Profit and Loss Statements for the last 5 (Five) financial years		
22	Self-attested copy of ITR for Last 5 Financial Year		
23	Copy of GST registration certificate, EPF, ESI		
24	Any other document asked by the Employer if submitted, specify the documents Or Any other document which the Bidder considers relevant		