

NOIDA METRO RAIL CORPORATION (NMRC) LIMITED

REQUEST FOR PROPOSAL (RFP)

E tender No. NMRC/DCOS/OHE/320/2024

Supply of Span Dropper Assembly for Traction Department

June 2024

Issued by:

**Noida Metro Rail Corporation (NMRC) Limited
Block-III, 3rd Floor,
Ganga Shopping Complex, Sector-29, Noida -201301,
District Gautam Budh Nagar, Uttar Pradesh, India**

Disclaimer

This Request for Proposal (RFP) Document (or “E-Tender” or “E-Bid”) for “**Supply of Span Dropper Assembly for Traction Department**” contains brief information about the scope of work and selection process for the Bidder (‘the Contractor’ or “the Bidder” or “the Applicant”). The purpose of the Document is to provide the Bidders with information to assist the formulation of their Bidding Documents.

While all efforts have been made to ensure the accuracy of information contained in this RFP Document, this Document does not purport to contain all the information required by the Bidders. The Bidders should conduct their own independent assessment, investigations and analysis and should check the reliability, accuracy and completeness of the information at their end and obtain independent advice from relevant sources as required before submission of their Bid/s. Noida Metro Rail Corporation Ltd. (“NMRC” or “the Corporation”) or any of its employees or advisors shall incur no liability under any law, statute, rules or regulations as to the accuracy or completeness of the RFP Document.

NMRC reserves the right to change any or all conditions/information set in this RFP Document by way of revision, deletion, updating or annulment through issuance of appropriate addendum as NMRC may deem fit without assigning any reason thereof.

NMRC reserves the right to accept or reject any or all Bids without giving any reasons thereof. NMRC will not entertain or be liable for any claim for costs and expenses in relation to the preparation of the Bid/s to be submitted in terms of this RFP Document.

Glossary

- a) **“Addendum / Amendment”** means any written amendment / addendum /corrigendum to this RFP, from time to time issued by NMRC to the prospective bidders;
- b) **“Agreement”** means the Contract Agreement to be executed between NMRC and the selected bidder.
- c) **“Applicable Laws”** means all laws, brought into force and effect by Govt. of India, State Governments, local bodies and statutory agencies and rules / regulations / notifications issued by them from time to time. It also include judgments, decrees, injunctions, writs and orders of any court or judicial authority as may be in force and effected from time to time.
- d) **“Bidder”** or **“Bidder”** means Sole proprietorship, registered partnership firm, public limited company, private limited company which is submitting its bid pursuant to RFP Documents
- e) **“Bid Due Date”** means Bid Submission end date and time given in the E-tender
- f) **“Earnest Money Deposit (EMD)”** means the refundable amount to be submitted by the Bidder along with RFP documents to NMRC
- g) **“Interest Free Security Deposit/ Performance Security”** means interest free amount to be deposited by the Contractor with NMRC as per terms and conditions of Contract Agreement as a security against the performance of the Contract agreement.
- h) **“NMRC”** means Noida Metro Rail Corporation Limited (or “Corporation”)
- i) **“Party”** means Contractor or Corporation (together they are called **“Parties”**)
- j) **“Performance Bank Guarantee/ Security Deposit”** means interest free amount to be deposited by the Contractor with NMRC as per terms and conditions of Purchase Order as a security against the performance of the Contract agreement
- k) **“Permits”** shall mean and include all applicable statutory, environmental or regulatory Contracts, authorization, permits, consents, approvals, registrations and franchises from concerned authorities
- l) **“Re. or Rs. or INR”** means Indian Rupee
- m) **“Revenue Operations Date (ROD)”** means the date of operation of metro
- n) **“Selected Bidder”** means the bidder who has been selected by NMRC, pursuant to the bidding process for award of Contract.

The words and expressions beginning with capital letters and defined in this document shall, unless repugnant to the context, have the meaning ascribed thereto hereinabove.

Data Sheet

1	Name of the Bid	RFP for Supply of Span Dropper Assembly for Traction Department
2	Approximate Cost of Work	INR 23,39,480/-(Inclusive of GST)
3	Time-period of contract	120 Days Delivery and 12 Months Warranty
4	Method of selection	Cost Based Selection (Lowest –L1)
5	Bid Processing Fee	INR 5,900/- (including GST) (Rupees Five Thousand Nine Hundred only) through RTGS/NEFT only payable in favour of Noida Metro Rail Corporation Limited
6	Ernest Money Deposit (EMD)	Rs. 46,800/- (Rupees Forty Six Thousand Eight Hundred Only) through RTGS/NEFT payable in favour of Noida Metro Rail Corporation Limited
7	Financial Bid to be submitted together with Technical Bid	Yes
8	Name of the Corporation's official for addressing queries and clarifications	Dy.COS Noida Metro Rail Corporation Limited, Block-III, 3rd Floor, Ganga Shopping Complex, Sector-29, Noida 201301 Email: nmrc.afc@gmail.com Website: www.nmrcnoida.com , http://etender.up.nic.in
9	Bid Validity Period	180 days
10	Bid Language	English
11	Bid Currency	INR
12	Schedule of Bidding Process	
	Task	Key Dates
	Uploading of Bid	June 15,2024
	Pre-bid Meeting	June 20,2024 [Time 11:00 hrs]
	Last date of receipt of Pre-bid queries	June 21 ,2024 [Time 11:30 hrs]
	Last date of issuing amendment, if Any	June 26,2024
	Last Date of Bid Submission	July 15,2024 [Time 15:00 hrs]
	Date of Technical Bid Opening	July 15,2024 [Time 15:30 hrs]
13	JV/Consortium to be allowed	No
14	Account details	For Bid Processing Fee & EMD State Bank of India (04077) – Sector 18, Noida Gautam Budh Nagar, Uttar Pradesh -201301 IFSC Code: SBIN0004077 A/c No. 37707840592 Noida Metro Rail Corporation Ltd.

Note: (i) Tender Cost and Tender Security is4 exempted for Micro & Small Enterprises (MSEs) registered with District Industries Centre or Khadi & Village Industries Commission or Khadi & Village Industries Board or Coir Board or National Small Industries Corporation or Dte. Of Handicraft & Handloom or any other bodies specified by Ministry of Micro, Small & Medium Enterprises for appropriate category and have valid registration certificate as on date of tender submission.

The MSEs would not be eligible for exemption of tender security if:

- a. Either they are not registered for appropriate category.
- b. Or they do not have valid registration as on the date of tender submission.

The bidders seeking exemption from 'tender security', being MSEs, shall ensure their eligibility w.r.t above and submit registration certificate issued by the body under which they are registered which clearly mentions category of registration i.e. "Supply/Manufacturing of Electrical Equipments" and Terminal Validity of registration.

In absence of any of the above requirements no exemption for 'tender security' will be allowed and bidder's eligibility shall be dealt as if they are not registered with MSMEs.

No further clarification shall be sought on the above.

1. In case the bidder who has been exempted Tender Cost/Tender Security being Micro & Small Enterprise, and;
 - (i) withdraws his Tender during the period of Tender validity; or
 - (ii) becomes the successful bidder, but fails to commence the work (for whatsoever reasons) as per terms & conditions of Tender; or
 - (iii) refuses or neglects to execute the contract; or
 - (iv) fails to furnish the required Performance Security within the specified time,

The bidder shall be debarred from participating in future tenders for a period of 1 year from the date of discharge of tender/date of cancellation of NOA/annulment of award of contract as the case may be. Thereafter, on expiry of period of debarment, the bidder may be permitted to participate in the procurement process only on submission of required Tender Cost/ Tender Security.

Further the Employer may advise the authority responsible for issuing the exemption certificate to take suitable actions against the bidder such as cancellation of enlistment certificate etc.

Content

Disclaimer	1
Data Sheet.....	3
1. Section 1: General Information	6
Background.....	6
About Locations	6
Communication	6
2. Section 2: Terms of Reference	7
Tenure	7
Scope of work	7
Obligation To contractor	7
3. Section 3: Instructions to Bidders.....	8
General instructions	8
Preparation and submission of Bids.....	10
Earnest Money Deposit.....	14
Opening and Evaluation of Bids.....	15
Award of Contract	16
4. Section 4: Eligibility, Evaluation and Selection Process.....	18
Eligibility Criteria.....	18
Information of the Technical and Financial Proposal	19
Purchase Order.....	19
Performance Bank Guarantee / Security Deposit	20
Contract during Proposal Evaluation	21
Project Financial Terms	21
5. Section 5: Special Conditions of Contract (SCC).....	22
6. Section 6: Forms.....	26
Form 1: Letter of Proposal Submission.....	26
Form 2: Firm Details.....	27
Form 3: Work Experience	28
Form 4: Financial Capability Details	29
Form 5: Memorandum	31
Form 6: Undertaking.....	32
Form 7: Saleable Form for Tender Document.....	33
Form 8: Declaration of Refund of Earnest Money.....	34
Form 9: Bid Offer/ BOQ (Format).....	35
Form 10: Bid Details.....	38
 ANNEXURES:	
Annexure A.....	39

1. Section 1: General Information

Background

- a. Noida and Greater Noida are being developed as the satellite towns to New Delhi and more and more people from Delhi and other areas are shifting to these towns in search of fresh air, greenery and better infrastructure. There is a need of providing an efficient, reliable and comfortable transportation system for the population intending to settle in these towns and also the public coming to these areas for education, service and business.
- b. Noida Metro Rail Corporation is a Special Purpose Vehicle (SPV) formed for planning and executing urban transport projects in Noida, Greater Noida regions. The Company desires to provide a world-class Public Transportation System with state-of-the-art technology. As such, the overarching criterion for setting up of the Company is to help create an efficient, safe, reliable, economical and affordable public transport system
- c. An elevated metro line between Noida and Greater Noida is already in operation.
- d. NMRC invites E-Bids for selection of Contractor for granting the Contract for **Supply of Span Dropper Assembly for Traction Department at NMRC Depot.**
- e. In this regard, the Corporation now invites the interested Bidder/s to submit their proposals as per provisions of this Request for Proposal Document.
- f. NMRC will shortlist the Bidders on the basis of evaluation criteria mentioned in this RFP Document. On the basis of the minimum evaluation criteria, qualified Bidders will be shortlisted. Financial proposal of only qualified Bidders will be opened.
- g. The Successful Bidder shall provide the services as described in Section 2: Terms of Reference.

About Locations

The metro corridor is 29.7 km long and is known as Noida Greater Noida Metro Rail Corridor. It comprises 21 metro stations starting from Noida Sector 51 in Noida and ends up at Depot Station in Greater Noida. The Various Oils and Grease are to be supplied at Main Stores (DCOS) Building, Metro Depot at Greater Noida.

Communication

All communications should be addressed to:

Dy.COS
Noida Metro Rail Corporation (NMRC) Limited
Block-III, 3rd Floor, Ganga Shopping Complex, Sector-29,
Noida -201301
District Gautam Buddha Nagar, Uttar
Pradesh Email: nmrc.afc@gmail.com

2. Section 2: Terms of Reference

2.1 Tenure:

The term shall be up to 120 days (Delivery period) from commencement of contract, unless otherwise terminated by the Parties in accordance with the terms and conditions. This agreement may be renewed or extended for any period as may be agreed by the parties.

2.2 Scope of Supply

2.2.1 Tender includes Supply of **2200 No. of Span Dropper Assemblies** for Traction Department at NMRC Depot as per below mentioned specifications-

1 (One) Span Dropper Assembly includes following items-

S.No.	Item Name	Specification	Qty.
1	Thimble	As per Annexure-A	2 No.
2	Compression connector	As per Annexure-A	2 No.
3	Dropper clip	As per Annexure-A	1 No.
4	Cable lug	As per Annexure-A	2 No.
5	Catenary wire clip	As per Annexure-A	1 No.
6	Contact wire clip	As per Annexure-A	1 No.
7	Contact wire	As per Annexure-A	1.66 mtr
8	Hexagon Nut and Bolt with Check nut 10M, SS A2 70	-	2 Bolt, 2 Nut, 1 Check Nut

- 2.2.2 The successful bidder shall supply span dropper wire of complete length (3652 mtrs) in cable drums of 500 mtr length.
- 2.2.3 The scope of supply under the contract may be reduced/curtailed based on NMRC's requirements as deemed fit. No claim or compensation will be entertained on this account.
- 2.2.4 All the Items will be received by Main Stores Department at NMRC Depot. No Payment will be made for any item found defective.
- 2.2.5 During tender submission, bidder shall be required to submit type test report fulfilling the required specifications. Bids without type test report may be rejected by NMRC.
- 2.2.6 The successful bidder shall seek manufacturing clearance after approval of design document by engineer in charge.
- 2.2.7 **Pre-dispatch inspection at Successful bidder premises:** Before dispatch, the goods will be inspected by NMRC or by Nominated External Inspection Agency (independently or jointly with NMRC) at Successful bidder's premises for their compliance to the contract specifications.

2.3 Obligation to the Contractor

If any damages / loss / theft etc. occurs in the NMRC premise, shall be the sole responsibility of the contractor and necessary compensation shall be paid by the contractor to NMRC as per the actual cost assessed by NMRC.

The contractor shall indemnify and hold NMRC harmless from and against all claims, damages, losses and expenses arising out of, or resulting from the works/services under the contract provided by the contractor.

Contractor shall ensure that its personnel shall not at any time, without the consent of NMRC, in writing, divulge or make known any trust, accounts, matter or transaction undertaken or handled by NMRC and shall not disclose to any person information to the affairs of NMRC.

All necessary reports, records, registers and other information, under the Contract and all other Statutory Laws, shall be deposited by the contractor on demand by NMRC.

Any damage or loss caused by contractor's persons to the property & equipments of NMRC Ltd. in whatever form may be recovered from the contractor. Contractor shall not be held responsible for the damages/sabotage caused to the property of NMRC due to the trade union / riots / mobs / armed dacoit activities or any other event of force majeure.

Any liabilities arising out of any litigation (including those in consumer courts) due to any act of contractor's personnel shall be directly borne by contractor including all expenses/fines. The concerned contractor's personnel shall attend the court as & when required.

3. Section 3: Instructions to Bidders

3.1 General instructions

- a. A bidder shall submit only one bid in the same tendering process. A bidder who submits or participates in, more than one bid will cause all of the proposals in which the bidder has participated to be disqualified.
- b. The Bidder shall initiate, and actively pursue and involve itself in all investigations and enquiries, Corporation feedbacks, information, convening of and attendance at meetings, and in any other activities as are or may be necessary for producing high quality work as per the requirements.
- c. The Bidder shall carry out the services in compliance with the provisions of this Agreement. Any and all changes necessary to ensure that the Bidder's documents conform to the intent and purpose set out in the Agreement, shall be made at the Bidder's own expense. The Bidder represents that it is a professional and experienced company, and hereby agrees to bear full responsibility for the correctness and technical merit of the services performed.
- d. Bidders shall be evaluated on the basis of the Evaluation Criteria specified in this document. Bidders shall be deemed to have understood and agreed that no explanation or justification for any aspect of the Selection Process will be given and that NMRC's decisions are without any right of appeal whatsoever.
- e. Any entity which has been barred by the Central/State Government in India or by any entity controlled by them, from participating in any project, and the bar subsists as on the date of Bid, would not be eligible to submit an e - Bid.
- f. Bidders are encouraged to inform themselves fully about the assignment and the local conditions before submitting the e-Bid by paying a visit to the Corporation and/or by sending written queries to NMRC before the last date for receiving queries/clarifications.
- g. NMRC shall not be liable for any omission, mistake or error on the part of the Bidder in respect of any of the above or on account of any matter or thing arising out of or concerning or relating to e-Bid or the Selection Process, including any error or mistake therein or in any information or data given by NMRC.
- h. The currency for the purpose of the Proposal shall be the Indian Rupee (INR).

- i. Bidders shall not have a conflict of interest. All Bidders found to have a conflict of interest shall be disqualified. Bidders shall be considered to have a conflict of interest with one or more parties in this bidding process, if:
 - i. A bidder has been engaged by the Employer to provide consulting services for the preparation related to procurement or implementation of the project;
 - ii. A bidder is any associates/affiliates (inclusive of parent firms) mentioned in sub paragraph above; or
 - iii. A bidder lends, or temporarily seconds its personnel to firms or organizations which are engaged in consulting services for the preparation related to procurement for an implementation of the project, if the personnel would be involved in any capacity on the same project.

Cost of Bid Document / e-Tender processing Fee

- a. The bidder shall bear all costs associated with the preparation and submission of its e-Bid and Noida Metro Rail Corporation Ltd. ("NMRC" or "the Corporation"), will in no case be responsible or liable for these costs, regardless of the conduct or outcome of the e-Bid process.
- b. This tender document is available on the web site <http://etender.up.nic.in> or on NMRC website (www.nmrcnoida.com) to enable the bidders to view, download the e-Bid document and submit e-Bids online up to the last date and time mentioned in e-Tender notice/e-tender document against this e-Tender. The bidders shall have to pay cost of bid document/ e- Tender processing fee of as mentioned in Data Sheet through RTGS/NEFT only payable in favor of Noida Metro Rail Corporation Limited in the A/c No. mentioned in Data Sheet. The scanned copy of RTGS/NEFT receipt with transaction Id certified by the same bank must be enclosed along with the e-Bid. This cost of bid document/ e-Tender processing fee as mentioned in Data Sheet will be non-refundable. Tender without cost of bid document/ e-Tender processing fee in the prescribed form, will not be accepted.

Acknowledgement by Bidder

It shall be deemed that by submitting the e-Bid, the Bidder has:

- a. made a complete and careful examination of the e-Bid;
- b. received all relevant information requested from NMRC;
- c. acknowledged and accepted the risk of inadequacy, error or mistake in the information provided in the e-Bid or furnished by or on behalf of NMRC;
- d. satisfied itself about all matters, things and information, necessary and required for submitting an informed Application and performance of all of its obligations there under;
- e. acknowledged that it does not have a Conflict of Interest; and
- f. Agreed to be bound by the undertaking provided by it under and in terms hereof.

Availability of Bid Document

This Bid document is available on the web site <http://etender.up.nic.in> or on Noida Metro website www.nmrcnoida.com to enable the Bidders to view, download the e-Bid document and submit e-Bids online up to the last date and time mentioned in e-Bidder notice/ e-Bid document. The Bidder's shall have to pay e-Bid document fee and EMD as mentioned in Data sheet through RTGS/ NEFT on addresses given in data sheet. The scanned copy of RTGS/ NEFT with transaction ID certified by the same bank must be enclosed along with the e-Bid. This e-Bid document fee will be non-refundable. Bid without Bid fee in the prescribe form will not be accepted.

Clarifications of e-Bid

- a. During evaluation of e-Bid, NMRC may, at its discretion, ask the Bidder for a clarification of

his/her e-Bid. The request for clarification shall be in writing.

- b. Any queries or request for additional information concerning this RFP shall be submitted in writing or by fax and e-mail to the Dy.COS, NMRC only before or during Pre-Bid Meeting held at NMRC. The envelopes/ communication shall clearly bear the following identification/ title: "**Queries/ Request for Additional Information: RFP for Supply of Span Dropper Assembly for Traction Department**". The responses will be posted to all such queries on the official Website www.nmrcnoida.com. NMRC reserves the right not to respond to any questions or provide any clarifications, in its sole discretion, and nothing in this Clause shall be taken or read as compelling or requiring NMRC to respond to any question or to provide any clarification. A pre- submission meeting shall be called on the date mentioned in Data Sheet at NMRC Office. Any change corresponding to date, if any, shall be communicated to the Bidder vide NMRC/ e- Tendering website.
- c. In case the Bidder seeks for any queries, he shall send letter or e-mail to the correspondence address given in Data Sheet.
- d. However, NMRC shall not entertain any correspondence from the Bidders during the period of e-Bid opening to selection of the successful Bidder. Any wrong practice shall be dealt in accordance with the Section 5.14 of this e-Bid document under Fraud and Corrupt Practices.
- e. The Bidder is advised to visit and examine the Site of Works and its surroundings and obtain for himself on his own responsibility all information that may be necessary for preparing the Tender and entering into a contract for the proposed work. The costs of visiting the Site shall be borne by the Bidder. It shall be deemed that the Contractor has undertaken a visit to the Site of Works and is aware of the site conditions prior to the submission of the tender documents.
- f. The Bidder and any of his personnel will be granted permission by the Employer to enter upon his premises and lands for the purpose of such inspection, but only upon the express condition that the Bidder, and his personnel, will release and indemnify the Employer and his personnel from and against all liability in respect thereof and will be responsible for death or personal injury, loss of or damage to property and any other loss, damage, costs and expenses incurred as a result of the inspection.

Amendment of e-Bid Document

- a. At any time prior to the deadline for submission of e-Bid, NMRC may, for any reason, whether at its own in iterative or in response to a clarification requested by a prospective Bidder, modify the e-Bid document by amendments. Such amendments shall be uploaded on the e-procurement website <http://etender.up.nic.in> or NMRC's website www.nmrcnoida.com. The relevant clauses of the e-Bid document shall be treated as amended accordingly.
- b. It shall be the sole responsibility of the prospective Bidder to check the web site <http://etender.up.nic.in> and NMRC's website www.nmrcnoida.com from time to time for any amendment in the e-Bid documents. In case of failure to get the amendments, if any, NMRC shall not be responsible for it.
- c. In order to allow prospective e-Bids a reasonable time to take the amendment into account in preparing their e-Bids, NMRC, at the discretion, may extend the deadline for the submission of e-Bids. Such extensions shall be uploaded on the e-procurement website <http://etender.up.nic.in> or NMRC's website www.nmrcnoida.com.

3.2 Preparation and submission of Bids

3.2.1 Language of e-Bid

The e-Bid prepared by the Bidder, as well as all correspondence and documents relating to the e-Bid exchanged by the Bidder and NMRC shall be written in English language. Only English numerals shall be used in the e-Bid. The correspondence and documents in any other language must be accompanied by transcripts verified by the Embassy of Home Country or equivalent.

3.2.2 Documents constituting the e-Bid

The e-Bid prepared by the Bidder shall comprise the following components:

a. Technical e-Bid- Technical e-Bid will comprise of -

- i. **Fee details** - Details of Bid processing fee and prescribed EMD
- ii. **Eligibility details** - Includes copies of required documents in PDF format justifying that the Bidder is qualified to perform the contract if his/her bid is accepted and the Bidder has financial & technical capability necessary to perform the contract and meets the criteria outlined in the Qualification requirement and technical specification and fulfill all the conditions of the contract.
- iii. **Technical evaluation** - Details of all documents needed for Technical evaluation as mentioned in this RFP

b. Financial e-Bid -

- i. **Price bid** – Bill of Quantities in XLS format to be filled in after downloading from the e-Procurement website for this e-tender (<http://etender.up.nic.in>). There shall be a single financial quote for the package for which the bid is submitted.

3.2.3 Documents establishing Bidder's Qualification

- c. The Bidder shall furnish, as part of its technical e-Bid, documents establishing the Bidder's qualification to perform the contract if its e-Bid is accepted. The documentary evidence should be submitted by the Bidder electronically in the PDF format.
- d. The documentary evidence of Bidder's qualification to perform the contract if its e-Bid is accepted shall be as per qualification requirements specified in e-Bid document.

3.2.4 E-Bid form

The Bidder shall complete the e-Bid form and the appropriate price schedule/BOQ furnished in the e-Bid document.

3.2.5 E-Bid Currency

Prices shall be quoted in Indian Rupees only.

3.2.6 Formats and Signing of e-Bid

- a. The Bidder shall prepare one electronic copy of the technical e-Bid and financial e-Bid separately.
- b. The e-Bid document shall be digitally signed, at the time of uploading, by the Bidder or a person or persons duly authorized to bind the Bidder to the contract. The later authorization shall be indicated by a scanned copy of written power-of attorney accompanying the e-Bid. All the pages/documents of the e-Bid that are to be uploaded shall be digitally signed by the person authorized to sign the e-Bid.
- c. Bidders should provide all the information as per the RFP and in the specified formats. NMRC reserves the rights to reject any proposal that is not in the specified formats.
- d. In case the Bidders intends to provide additional information for which specified space in the given format is not sufficient, it can be furnished in duly stamped and signed PDFs.

3.2.7 Deadline for submission of e-Bid

E-Bid (Technical and financial) must be submitted by the Bidder at e-procurement website <http://etender.up.nic.in> not later than the time specified on the prescribed date (as the server time displayed in the e-procurement website). NMRC may, at its discretion, extend this deadline for submission of e-Bid by amending the e-Bid document, in which case all rights and obligations of NMRC and Bidders previously subject to the deadline will thereafter be subject to the deadline as extended.

3.2.8 Submission of e-Bid

- a. The bid submission module of e-procurement website <http://etender.up.nic.in> enables the Bidders to submit the e-Bid online in response to this e-Bid published by NMRC.
- b. Bid submission can be done only from the bid submission start date and time till the bid submission end date and time given in the e-Bid. Bidders should start the bid submission process well in advance so that they can submit their e-Bid in time.
- c. The Bidder should submit their e-Bid considering the server time displayed in the e-procurement website. This server time is the time by which the e-Bid submission activity will be allowed till the permissible time on the last/end date of submission indicated in the e-Bid schedule.
- d. Once the e-Bid submission date and time is over, the Bidders cannot submit their e-Bid. For delay in submission of e-Bid due to any reasons, the Bidders shall only be held responsible.

3.2.9 The Bidders have to follow the following instructions for submission of their e-Bid:

- a. For participating in e-Bid through the e-Bidding system it is necessary for the Bidders to be the registered users of the e-procurement website <http://etender.up.nic.in>. The Bidders must obtain a user login Id and password by registering themselves with U.P. Electronics Corporation Ltd. Lucknow if they have not done so previously for registration.
- b. In addition to the normal registration, the Bidder has to register with his/her digital signature certificate (DSC) in the e-Bidding system and subsequently he/she will be allowed to carry out his/her e-Bid submission activities. Registering the digital signature certificate (DSC) is a one-time activity. Before proceeding to register his/her DSC, the Bidder should first log on to the e-Bidding system using the user login option on the home page with the login Id and password with which he/she has registered.

For successful registration of DSC on e-procurement website <http://etender.up.nic.in> the Bidder must ensure that he/she should possess class-2/class-3 DSC issued by any certifying authorities approved by controller of certifying authorities, Government of India, as the e-procurement website <http://etender.up.nic.in> is presently accepting DSC issued by these authorities only. The Bidder can obtain user login Id and perform DSC registration exercise given above even before the e-Bid submission date starts. NMRC shall not be held responsible if the Bidder tries to submit his/her e-Bid at the moment before end date of submission but could not submit due to DSC registration problem.

- c. The Bidder can search for active Bids through "search active tenders" link, select a Bid in which he/she is interested in and then move it to 'My Tenders' folder using the options available in the e-Bid submission menu. After selecting and the Bid, for which the Bidder intends to e-Bid, from "My tenders" folder, the Bidder can place his/her e-Bid by clicking "pay offline" option available at the end of the view Bid details form. Before this, the Bidder should download the e-Bid document and price schedule/bill of quantity (BOQ) and study them carefully. The Bidder should keep all the documents ready as per the requirements of e-Bid document in the PDF format except the price schedule /bill of quantity (BOQ) which should be in the XLS format (excel sheet).
- d. After clicking the 'pay offline' option, the Bidder will be redirected to terms and conditions page. The Bidder should read the terms & conditions before proceeding to fill in the Bid fee and EMD offline payment details. After entering and saving the Bid fee and EMD details form so that "bid document preparation and submission" window appears to upload the documents as per technical (fee details, qualification details, e-Bid form and technical specification details) and financial (e-Bid form and price schedule/BOQ) schedules/packets given in the Bid details. The details of the RTGS/NEFT should tally with the details available in the scanned copy and the date entered during e-Bid submission time otherwise the e-Bid submitted will not be accepted.
- e. Next the Bidder should upload the technical e-Bid documents for fee details (e-Bid fee and EMD), Qualification details. Before uploading, the Bidder has to select the relevant digital signature

certificate. He may be prompted to enter the digital signature certificate password, if necessary. For uploading, the Bidder should click "browse" button against each document label in technical and financial schedules/packets and then upload the relevant PDF/XLS files already prepared and stored in the Bidder's computer. The required documents for each document label of technical (fee details, qualification details, e-Bid form and technical specification details) and financial (e-Bid form and price schedule/BOQ) schedules/packets can be clubbed together to make single different files for each label.

- f. The Bidder should click "Encrypt" next for successfully encrypting and uploading of required documents. during the above process, the e-Bid document are digitally signed using the DSC of the Bidder and then the documents are encrypted/locked electronically with the DSC's of the bid openers to ensure that the e-Bid documents are protected, stored and opened by concerned bid openers only.
- g. After successful submission of e-Bid document, a page giving the summary of e-Bid submission will be displayed confirming end of e-Bid submission process. The Bidder can take a printout of the bid summary using the "print" option available in the window as an acknowledgement for future reference.
- h. NMRC reserves the right to cancel any or all e-Bids without assigning any reason.

3.2.10 Late e-Bid

- a. Bids received by NMRC after the specified time on the Bid Due Date shall not be eligible for consideration and shall be summarily rejected.
- b. The server time indicated in the bid management window on the e- procurement website <http://etender.up.nic.in> will be the time by which the e-Bid submission activity will be allowed till the permissible date and time scheduled in the e-Bid.
- c. Once the e-Bid submission date and time is over, the Bidder cannot submit his/her e-Bid. Bidder has to start the bid submission well in advance so that the submission process passes off smoothly. The Bidder will only be held responsible if his/her e-Bid is not submitted in time due to any of his/her problems/faults, for whatsoever reason, during e-Bid submission process.

3.2.11 Withdrawal and resubmission of e-Bid

- a. At any point of time, a Bidder can withdraw his/her e-Bid submitted online before the bid submission end date and time. For withdrawing the Bidder should first log in using his/her login id and password and subsequently by his/her digital signature certificate on the e-procurement website <http://etender.up.nic.in>. The Bidder should then select "My bids" option in the bid submission menu. The page listing all the bids submitted by the Bidder will be displayed. Click "View" to see the details of the bid to be withdrawn. After selecting the "bid withdrawal" option the Bidder has to click "Yes" to the message "Do you want to withdraw this bid?" displayed in the bid information window for the selected bid. The Bidder also has to enter the bid withdrawing reasons and upload the letter giving the reasons for withdrawing before clicking the "Submit" button. The Bidder has to confirm again by pressing "OK" button before finally withdrawing his/her selected e-Bid.
- b. No e-Bid may be withdrawn in the interval between the deadline for submission of e-Bids and the expiration of period of e- bid validity. Withdrawal of an e-Bid during this interval may result in the forfeiting of Bidder's e-Bid security.
- c. The Bidder can re-submit his/her e-Bid as when required till the e-Bid submission end date and time. The e-Bid submitted earlier will be replaced by the new one. The payment made by the Bidder earlier will be used for revised e-Bid and the new e-Bid submission summary generated after the successful submission of the revised e-Bid will considered for evaluation purposes. For resubmission, the Bidder should first log in using his/her login Id and password and subsequently by his/her digital signature certificate on the e-procurement website <http://etender.up.nic.in>. The Bidder should then select "My bids" option in the bid submission menu. The page listing all the bids

submitted by the Bidder will be displayed. Click "View" to see the detail of the e-Bid to be resubmitted. After selecting the "bid resubmission" option, click "Encrypt & upload" to upload the revised e-Bids documents.

- d. The Bidder can submit their revised e-Bids as many times as possible by uploading their e-Bid documents within the scheduled date & time for submission of e-Bids.
- e. No e-Bid can be resubmitted subsequently after the deadline for submission of e-Bids.

3.2.12 NMRC's right to accept any e-Bid and to reject any or all e-Bids.

- a. Notwithstanding anything contained in this e-Bid, NMRC reserves the right to accept or reject any Bid and to annul the Selection Process and reject all Bids, at any time without any liability or any obligation for such acceptance, rejection or annulment, and without assigning any reasons thereof.
- b. NMRC reserves the right to reject any Bid if:
 - At any time, a material misrepresentation is made or uncovered, or
 - The Bidder does not provide, within the time specified by NMRC, the supplemental information sought by NMRC for evaluation of the e-Bid.
- c. Such misrepresentation/ improper response may lead to the disqualification of the Bidder. If such disqualification /rejection occurs after the e-Bid have been opened and the highest ranking Bidder gets disqualified / rejected, then the NMRC reserves the right to consider the next best Bidder, or take any other measure as may be deemed fit in the sole discretion of NMRC, including annulment of the Selection Process.

3.2.13 Period of validity of e-Bid

- a. e-Bid shall remain valid for 180 days after the date of e-Bid opening prescribed by NMRC. An e-Bid valid for a shorter period shall be rejected by NMRC as non-responsive.
- b. In exceptional circumstances, NMRC may solicit the Bidder's consent to an extension of the period of e-Bid validity. The request and the response thereto shall be made in writing.

3.2.14 Correspondence with the Bidder

- a. Save and except as provided in this e-Bid, NMRC shall not entertain any correspondence with any Bidder or its Technical Partners in relation to acceptance or rejection of any e-Bid.
- b. No Bidders or its Technical Partners shall contact NMRC on any matter relating to his e-Bid from the time of Bid opening to the time contract is awarded.
- c. Any effort by the Bidder or by its Technical Partners to influence NMRC in the Bid evaluation, Bid comparison or contract award decisions, may result in the rejection of his Bid.

3.3 Earnest Money Deposit

3.3.1 Earnest money deposit (EMD)

- a. The bidder shall furnish, as part of its e-Bid, an e-Bid security/ EMD as stated in Data Sheet in form of RTGS/NEFT only in favour Noida Metro Rail Corporation Limited in the A/c No. mentioned in Data Sheet. The scanned copy of RTGS/NEFT receipt of Security/ EMD with transaction Id certified by the same bank must be enclosed along with the e-Bid. Tender without Earnest Money in the prescribed form, will not be accepted.
- b. Bidders submitting bids for more than one package shall be required to submit EMD for each package as mentioned in Data Sheet for which bid is submitted.
- c. Any e-Bid not secured in accordance with above shall be treated as non-responsive and rejected by NMRC.
- d. Unsuccessful Bidder's EMD will be returned within 45 days after conclusion or discharge of the

tender. No interest will be paid by the Purchaser on the Earnest Money Deposit.

- e. The successful Bidder's e-Bid EMD will be adjusted with Performance Bank Guarantee, if applicable, to be submitted by the Bidder upon signing the contract.
- f. The EMD may be forfeited:
 - i. If Bidder (a) withdraws its e-Bid during the period of e-Bid validity specified by the Bidder on the e- bid form: or (b) does not accept the correction of errors or (c) modifies its e-Bid price during the period of e-Bid validity specified by the Bidder on the form.
 - ii. In case of a successful Bidder, if the Bidder fails to sign the contract with the Corporation.

3.4 Opening and Evaluation of Bids

3.4.1 Opening of technical e-Bid by NMRC

- a. NMRC will open all technical e-Bids, in the presence of Bidder`s representatives who choose to attend on the prescribed date of opening at NMRC Office. The Bidder's representatives who are present shall submit the letter to NMRC on the letter head of the company stating that the representative (name) is authorized to attend the meeting (Please note – The representative is required to carry a copy during pre-bid and other related meetings as well). He / She shall sign a register evidencing their attendance at NMRC. In the event of the specified date e-Bid opening being declared a holiday for the Corporation, the e –bids shall be opened at the appointed time and place on the next working day.
- b. The Bidder who is participating in e-Bid should ensure that the RTGS/NEFT of Bid Processing Fee and EMD must be submitted in the prescribed account of NMRC within the duration (strictly within opening & closing date and time of individual e-Bid) of the work as mentioned in Bid notice, otherwise, in any case, e-Bid shall be rejected.
- c. The Bidders names and the presence or absence of requisite e-Bid security and such other details as NMRC at its discretion may consider appropriate, will be announced at the opening.

3.4.2 Opening of financial e-Bid

- a. After evaluation of technical e-Bid, through the evaluation committee NMRC shall notify those Bidders whose technical e-Bids were considered non-responsive to the conditions of the contract and not meeting the technical specifications and qualification requirements indicating that their financial e-Bids will not be opened.
- b. NMRC will simultaneously notify the Bidders, whose technical e-Bids were considered acceptable to the Corporation. The notification may sent by e-mail provided by Bidder.
- c. The financial e-Bids of technically qualified Bidders shall be opened in the presence of technically qualified bidders who choose to attend. The date and time for opening of financial bids will be communicated to the technically qualified Bidders subsequently after completion of technical bids evaluation through e-mail provided by the Bidder.

3.4.3 Correction of Errors

- a. Financial Bids determined to be responsive will be checked by NMRC for any arithmetic errors. Where there is a discrepancy between the rate quoted in the Financial Bid, in figures and in words, the amount in words will prevail over the amounts in figures, to the extent of such discrepancy.

- b. The amount stated in the Financial Bid will be adjusted by NMRC in accordance with the above procedure for the correction of errors and shall be considered as binding upon the Bidder. If the Bidder does not accept the corrected quoted rate of e-Bid, his e-Bid will be rejected, and his Bid Security shall be liable for forfeiture.

3.4.4 Examination of e-Bid document

- a. The NMRC will examine the e-Bid to determine if:
 - i. They are complete;
 - ii. They meet all the conditions of the contract;
 - iii. The required e-Bid Processing fee, EMD and other required documents have been furnished;
 - iv. The documents have been properly digitally signed; and
 - v. The e-Bids are in order.
- b. Any e-Bid or e-Bids not fulfilling these requirements shall be rejected.

3.4.5 Contacting NMRC

- a. No Bidder shall contact NMRC on any matter relating to his/her e-Bid, from the time of the e-Bid opening to the time the contract is awarded. If the Bidder wishes to bring additional information to the notice of NMRC, he/she can do so in writing.
- b. Any effort by a Bidder to influence NMRC in its decisions on e-Bid evaluation, e- bid comparison or contract award may result in rejection of the Bidder's e-Bid.
- c. In the event of any information furnished by the Bidder is found false or fabricated, the minimum punishment shall be debarring /blacklisting from Noida Metro works and legal proceeding can also be initiated. EMD of such bidders will be forfeited.

3.4.6 Confidentiality

- a. Information relating to the examination, clarification, evaluation, and recommendation for the Bidders shall not be disclosed to any person who is not officially concerned with the process or is not a retained professional advisor advising NMRC in relation to or matters arising out of, or concerning the Bidding Process. Any effort by a Bidder to exert undue or unfair influence in the process of examination, clarification, evaluation and comparison of Proposal shall result in outright rejection of the offer, made by the said Bidder.
- b. NMRC shall treat all information, submitted as part of Bid, in confidence and shall require all those who have access to such material to treat the same in confidence. NMRC may not divulge any such information unless it is directed to do so by any statutory entity that has the power under law to require its disclosure or is to enforce or assert any right or privilege of the statutory entity and/ or NMRC or as may be required by law or in connection with any legal process.

3.5 Award of Contract

3.5.1 Award Criteria

- a. NMRC will award the contract as per evaluation criteria stated in the RFP Document.
- b. NMRC will award the contract to the successful Bidder whose bid has been determined to be responsive to all the conditions of the contract and meeting the eligibility requirement of the bidding document.

3.5.2 Purchase Order

- a. Prior to the expiration of the period of e-Bid validity, NMRC will issue Purchase order to the successful Bidder in writing, by letter/e-mail.
- b. The successful bidder shall have to provide unconditional acceptance of the purchase order along

with Performance Bank Guarantee / Security Deposit within 15 days of receipt of purchase order. Upon the receipt of the unconditional acceptance of Purchase order along with Performance Bank Guarantee / Security Deposit, a legally binding contract shall be deemed to have commenced between NMRC and successful bidder.

3.5.3 NMRC's right to accept any e-Bid and to reject any or all e-Bids

NMRC reserves the right to accept or reject any e-Bid, and to annul the e-Bid process and reject all e-Bids at any time prior to contract award, without thereby incurring any liability to the affected bidder or bidders.

4. Section 4: Eligibility, Evaluation and Selection Process

4.1 Eligibility Criteria

The Bidder's competence and capability is proposed to be established by the following parameters. The Bidder should meet all the criteria given in this section.

- a) Sole proprietorship, registered partnership firm (including LLP), public limited company, private limited company can submit the Bid. The firms and the companies should be registered in India.
- b) The Bidder should have completed in India during last 7 (Seven) years period ending last day of month previous to the one in which the bids are invited should be either of the following:
 - i. One order of similar nature of value not less than Rs. 18.72 lakh (Rupees Eighteen Lakh Seventy Two Thousand only) or
 - ii. Two orders of similar nature of value not less than Rs 11.70 lakh (Rupees Eleven Lakh Seventy Thousand Only) each or
 - iii. Three orders of similar nature of value not less than Rs 9.36 lakh (Rupees Nine Lakh Thirty Six Thousand Only) each.

Definition of Similar Work: Works involving supply/manufacturing of high voltage electrical equipments in Railways or Metro Rail Projects.

- c) OEM of Bidders (either themselves or through resellers) should have metro experience for supply of Span Dropper Assemblies or should be RDSO approved for OHE (25 KV) category.
- d) The Bidder should have minimum average annual turnover of Rs. 23.39 Lakh (Rupees Twenty Three Lakh Thirty Nine Thousand only) in the last 3 (three) Financial Years (2021-22, 2022-23, 2023-24) preceding the Bid Due Date.
- e) Profit before tax should be positive in atleast 1 (one) year; out of the last 3 (three) audited financial years.
- f) The Bidder or its owners/partners have not been blacklisted/ banned/ declared ineligible for corrupt and fraudulent practices by the Government of India/ any State Government/ Government Agency and any court of law and contracts have been terminated/ foreclosed by any company/department due to non-fulfillment of Contractual obligation in last 5 (five) financial years.
- g) The Bidder should be registered with the Goods and Services Tax Authority.

The Bidder shall also furnish the following documentary proof:

- a. For above criteria 4.1a
 - i. Registration certificate of the firm/ Partnership deed/ certificate of incorporation, etc.
- b. For above criteria 4.1b
 - i. Form 3: Work Experience with documentary evidence
- c. For above criteria 4.1c
 - i. RDSO approval for OHE(25KV) category
 - or**
 - ii. one work order & completion certificate for work regarding supply of Span Dropper Assemblies in Metro Rail networks in last 7 years.
- d. For above criteria 4.1d & e
 - i. Form 4: Financial Capability Details
 - ii. A copy of the Audited balance sheets and Profit and Loss Statements for the last 3 (three) financial years

In case the Financial Statements for the latest financial year are not audited and therefore the Bidder cannot make it available, the Bidder shall give an undertaking to this effect and the statutory auditor/chartered accountant shall certify the same. In such a

case, the Bidder shall provide the Audited Financial Statements for 2 (two) years preceding the year for which the Audited Financial Statement is not being provided. Also, pertaining to latest financial year, the bidder shall submit an affidavit certifying that “The Annual Accounts have not been audited so far. We are submitting the CA certified provisional accounts, which shall be substantiated by the Audited Accounts, when prepared.”

- iii. Self attested copy of PAN, ITR (For last 3 audited FY's)

- e. For above criteria 4.1 g
 - i. Copy of GST registration certificate

- f. For above criteria 4.1f
 - i. Form 6: Undertaking

4.2 Information of the Technical and Financial Proposal

- i. The financial proposal of only technically qualified Bidders shall be opened for evaluation.
- ii. The Bidder satisfying the criteria under Section 4.1 shall be considered as qualified.

4.3 Selection of Bidder

NMRC shall award the Contract for Supply of Span Dropper Assembly for Traction Department to the Lowest Bidder (L1 bidder), whose tender has been determined to be substantially responsive and compliant to the requirements contained in the Tender Documents.

- i. In case, two or more technically qualified bidders quote the same rate
- ii. in the Commercial Bid, and become Lowest (i.e. L-1), then the tender would be awarded to the bidder who has the highest / higher Average Annual Turnover from ‘Similar Works’ (as per Minimum Eligibility Criteria defined in Section 4 under “Definition of Similar Work”) during the last 3 years ending on the last day of the month preceding the month in which the tender has been floated. Experience certificate / work completion certificate on client's letter head is mandatory to ascertain the nature, period and value of work which shall be required to be uploaded by the bidder by the last date of tender submission.
- iii. No correspondence will be entertained by NMRC from the unsuccessful bidders.

4.4 Purchase Order

- i. Prior to the expiration of the period of e-Bid validity, NMRC will issue Purchase order to the successful Bidder in writing, by letter/e-mail.
- ii. The successful bidder shall have to provide unconditional acceptance of the purchase order along with Performance Bank Guarantee / Security Deposit within 15 days of receipt of purchase order.
- iii. The Successful Bidder shall supply the required items within the time period as mentioned in purchase order or such extended period as may be decided by the Corporation.
- iv. Failure of the Successful Bidder to comply with the requirement of acknowledgement of Purchase Order shall constitute sufficient grounds for the annulment of the Purchase Order, and forfeiture of the bid security.
- v. The Purchaser/Buyer reserves the right to increase or decrease the quantity up to 25% of the quantity offered by the successful bidder. The bidder is bound to accept the increase or decrease in the tendered quantity up to 25% under this clause without any change in unit price.
- vi. In case the variation in individual items or the group of items as stipulated above, is more than 25% on plus side, the rate for the varied quantity beyond 25% shall be negotiated between the NMRC and the Contractor and mutually agreed rates arrived at before actual execution of the extra quantity. In case the contractor executes the extra quantity without written approval of the NMRC with specific instructions to execute pending the finalization of rates, the payment shall be made at contract rate

only. In the event of disagreement, the Engineer shall fix such rates of price as are, in his opinion appropriate and shall notify the Contractor accordingly, with a copy to the Employer. Until such time as rates or prices are agreed or fixed, the Engineer shall determine provisional rates or prices to enable on account payments to the Contractor. Alternatively, in the event of disagreement, the Contractor shall have no claim to execute extra quantities/new items and the Engineer shall be free to get such additional quantities beyond 25% new items executed through any other agency. However, if the Engineer or the Employer so directs the Contractor shall be bound to carry out any such additional quantities beyond the limits stated above original quantities and or new items and the disagreement or the difference regarding rates to be paid for the same shall be settled in the manner laid down under the conditions for the settlement of dispute.

4.5 Performance Bank Guarantee / Security Deposit

- i. To fulfill the requirement of performance bank guarantee during the implementation period, the Successful Bidder (herein referred to as the "Contractor") shall deposit 10% of the Contract Price in form of NEFT/RTGS, FDR, DD or unconditional and irrevocable Bank Guarantee bond issued by a scheduled bank in favor of Noida Metro Rail Corporation Limited valid for 18 months with the unconditional acceptance of Purchase Order. EMD amount of successful bidder shall be adjusted in the performance bank guarantee, if applicable. For unsuccessful bidder, EMD shall be refunded without any interest. In case of extension of tenure by 6 months, the performance bank guarantee shall be extended by 6 months as well. The bank guarantee must be issued by a bank branch located in Delhi/NCR, Noida or Greater Noida region.
- ii. If the successful bidder fails to submit Performance Bank Guarantee along with the acknowledgment of receipt of Purchase order, The extension of time for submission of Performance Security from beyond 15 days upto 45 days from issue of purchase order may be given by authority who is competent to sign the purchase order however a penal interest of 15% per annum shall be charged for the entire period. In case the contractor fails to submit the requisite performance security within 45 days from date of issue of purchase order the contract shall be annulled duly forfeiting tender security and other dues.
- iii. It is to note that if contract value increases by more than 25% of the original contract value, the performance bank guarantee shall be increased accordingly.
- iv. NMRC reserves the right for deduction of NMRC dues from Contractor's Performance Bank Guarantee/ Security Deposit (interest free) for – Any penalty imposed by NMRC for violation of any terms and conditions of agreement committed by the Contractor.
 1. Any amount which NMRC becomes liable to the Government/Third party due to any default of the Contractor or any of his director/ employees/ representatives/ servant/ agent, etc.
 2. Any payment/ fine made under the order/judgment of any court/consumer forum or law enforcing Contractor or any person duly empowered in his behalf.
 3. Any outstanding payment/ claims of NMRC remained due after completion of relevant actions as per agreement.
- v. Once the amount under above Clause is debited, the Contractor shall replenish the Security Deposit/ Performance Bank Guarantee to the extent the amount is debited within 15 days period,

Failing which, it shall be treated as Contractor Event of Default and will entitle NMRC to deal with the matter as per the provisions of RFP and Contract Agreement.

4.6 Contract during Proposal Evaluation

- i. Proposals shall be deemed to be under consideration immediately after they are opened and until such time NMRC makes official intimation of award/ rejection to the Bidders. While the Proposals are under consideration, Bidders and/ or their representatives or other interested parties are advised to refrain from contacting by any means, NMRC and/ or their employees/ representatives on matters related to the Proposals under consideration till the time Contract is awarded
- ii. Any effort by a Bidder to influence NMRC in its decisions on e-Bid evaluation, e-Bid comparison or contract award may result in rejection of the Bidder's e-Bid.
- iii. In the event of any information furnished by the agency is found false or fabricated the minimum punishment shall be debarred/ blacklisting and the legal proceeding may also be initiated.

- iv. If the Bidder wishes to bring additional information to the notice of NMRC, he/she can do so in writing. All correspondence/ enquiry should be submitted to the following in writing by fax/ post/courier:
Dy. COS
Noida Metro Rail Corporation (NMRC) Limited
Block-III, 3rd Floor, Ganga Shopping Complex, Sector-29,
Noida -201301
District Gautam Budh Nagar, Uttar Pradesh
Email: nmrc.afc@gmail.com
- v. No interpretation, revision, or other communication from NMRC regarding this solicitation is valid unless in writing and signed by the competent authority from NMRC.

4.7 Financial Terms

4.7.1 Payment Terms

The standard payment terms subject to recoveries, if any by way of Liquidated damages (LD) will be as under:

- a. 100% Payment will be made after-
 - i. Delivery of Various Oils and Grease at Main Stores (DCOS) Building, NMRC Depot.
 - ii. Acceptance/Receiving by NMRC.
 - iii. Submission of delivery Challan & E-way bill.
 - iv. Copies of bills in original with relevant supporting documents.
- b. No Payment shall be made in advance.
- c. No payment shall be made for the items rejected.
- d. GST will be paid only on the production of GST paid Challan or its reflection in the GSTR 2A on the GST portal of NMRC.
- e. Statutory deductions shall be made as per prevalent stature.

4.7.2. Liquidated Damages: If the contractor fails to deliver any or all of the Goods/Services within the original/re-fixed delivery period(s) specified in the purchase order, the NMRC will be entitled to deduct/recover the Liquidated Damages for the delay, unless covered under Force Majeure conditions aforesaid, @ 0.5% of the contract value of delayed quantity per week or part of the week of delayed period as pre-estimated damages not exceeding 10% of the contract value of delayed quantity without any controversy/dispute of any sort whatsoever.

Section 5: Special Conditions of Contract (SCC)

These conditions shall be part of the contract agreement.

5.1 General Provisions

5.1.1 Governing law and jurisdiction

These general conditions shall be governed by and construed in accordance with the laws in the territory of India. Irrespective of the place of delivery and the place of payment under the contract, the contract shall be deemed to have been made at the panel in India from where the acceptance of tender has been issued. Any dispute arising between the parties or arising out of this project or these terms shall be subject to the exclusive jurisdiction of, and venue in, the District court located in Gautam Budh Nagar, Uttar Pradesh, India.

5.1.2 Notices

Any notice, request or consent required or permitted to be given or made pursuant to these general conditions shall be in writing. Any such notice, request or consent shall be deemed to have been given or made when delivered in person to an authorized representative of the party to whom the communication is addressed, or when sent to such party at the mentioned address.

5.1.3 Authorized Representatives

Any action required or permitted to be taken, and any document required or permitted to be executed under these general conditions by the Corporation or the Successful Bidder may be taken or executed by the officials as formally designated by each party.

5.1.4 Taxes and Duties

- a. The Agency shall bear and pay all taxes, duties, levies and charges assessed on the Agency, its Sub Agencies or their employees by all municipal, state or national government authorities in connection with the Facilities in and outside India, the amount of which is deemed to have been included in the Contract Price.
- b. The Agency shall ensure full compliance with tax laws of India with regard to this contract and shall be solely responsible for the same. He shall keep the Employer fully indemnified against liability of tax, interest, penalty etc., of the Agency's in respect thereof, which may arise.

5.2 Commencement, Completion, Modification and Termination of Contract

a) Commencement of Services

The Agency shall begin carrying out the Services from the date of acceptance of Purchase Order or any such date as specified by the Corporation.

b) Expiration of Contract

Unless terminated earlier pursuant to Clause f) hereof, these general conditions shall expire at the end of such time period as given in the time schedule in RFP Document.

c) Modifications or Variations

Any modification or variation of the terms and conditions of these general terms, including any modification or variation of the scope of the Services, may only be made by written agreement between the Parties. However, each Party shall give due consideration to any proposals for modification or variation made by the other Party.

d) Termination of Contract

The NMRC may terminate the contract/agreement in case of violation /default in any terms & conditions of the agreement by the supplier/contractor.

e) Force Majeure

- (i)** Definition: For the purpose of these general terms, "Force Majeure" means an event which is beyond the reasonable control of a Party and which makes a Party's performance of its obligations under the Contract impossible or so impractical as to be considered impossible under the circumstances.
- (ii)** No Breach of Contract: The failure of a Party to fulfill any of its obligations under the contract shall not be considered to be a breach of, or default under, this Contract insofar as such inability arises from an event of Force Majeure, provided that the Party affected by such an event (a) has taken all reasonable precautions, due care and reasonable alternative measures in order to carry out the terms and conditions of this Contract, and (b) has informed the other Party as soon as possible about the occurrence of such an event.
- (iii)** Extension of Time: Any period within which a Party shall, pursuant to this Contract, complete any action or task, shall be extended for a period equal to the time during which such Party was unable to perform such action as a result of Force Majeure.
- (iv)** Payments: During the period of their inability to perform the Services as a result of an event of Force Majeure, the Agency shall be entitled for time extension for such period.

f) Termination of Contract

If the Agency fails to deliver the items within the period fixed for such delivery in the contract or as extended or at any time repudiates the contract before the expiry of such period, the purchaser may without prejudice to his other rights. The total amount of liquidated damages, however, not exceed the limit of liquidated damages -10%, after which contract will be deemed as cancelled & PBG will be encashed by the Purchaser.

g) Upon Termination of this Agreement for any reason whatsoever

The termination of this Agreement shall not release Agency to pay any sums then owing to the other party nor from the obligation to perform or discharge any liability that had been incurred prior thereto.

5.3 Insolvency and Breach of Contract

The Purchaser may at any time, issue notice in writing summarily terminate the contract without compensation to the Agency in any of the following events, that is to say –

- a.** If the Agency being an individual or a firm - Any partner thereof, shall at any time, be adjudged insolvent or shall have a receiving order or order for administration of his estate made against him or shall take any proceeding for composition under any Insolvency Act for the time being in force or make any conveyance or assignment of his effects or enter into any assignment or composition with his creditors or suspend payment or if the firm be dissolved under the Partnership Act, or
- b.** If the Agency being a company is wound up voluntarily or by the order of a Court or a Receiver, Liquidator, or Manager on behalf of the debenture holders is appointed, or circumstances shall have arisen which entitle the Court or Debenture holders to appoint a Receiver, Liquidator or Manager, or
- c.** If the Agency commits any breach of the contract not herein specifically provided for.
- d.** Provided always that such determination shall not prejudice any right of action or remedy which shall have accrued or shall accrue thereafter to the Purchaser and provided also the Agency shall be liable to pay to the Purchaser any extra expenditure he is thereby put to and the Agency shall, under no circumstances, be entitled to any gain on re purchase.

5.4 Warranty

- a.** The Bidder shall give warranty that the goods shall be new and free from defects and manufacture shall be of the highest grade and consistent with the established and generally accepted standards for materials of the type ordered.

- b. All the items supplied under this contract should have at least 12 months warranty against all kind of defects.
- c. If it becomes necessary for the Agency to replace or renew any defective portion/portions of the item under this clause, the provisions of the clause shall apply to the portion/portions of item's replaced or renewed. If any defect is not remedied within a reasonable time, the Purchaser may proceed to get the work done at the Agency's risk and expenses, but without prejudice to any other rights which the Purchaser may have against the Agency in respect of such defects.
- d. Replacement under warranty clause shall be made by the Agency free of all charges at site including freight, insurance and other incidental charges, as the case may be.

5.5 Inspection

- a. The Purchaser or its representatives or ultimate client shall have the right to inspect and test the goods for their conformity to the specifications as required.

5.6 Obligations of the Agency

- a. The Agency/Bidder shall undertake Supply of Span Dropper Assembly for Traction Department with due care and diligence in accordance with the Contract.
- b. Engagement of Staff and Labour- Except as otherwise stated in the Specification, the Agency shall ensure/ make arrangements for the engagement of all staff and labour, local or otherwise, and for their payment, transport, etc.

5.7 Packaging

- a. The Agency shall be responsible for packing, transporting, receiving, storing and protecting all items and other things required for the Works.

5.8 Obligations of Corporation

NMRC agrees to provide support to the Agency and undertake to observe, comply with and perform, subject to and in accordance with the provisions of the Agreement and the Applicable Laws.

5.9 Fraud and Corrupt Practices

- a. The Bidders and their respective officers, employees, agents and advisers shall observe highest standard of ethics during Bidding Process and subsequent to issue of Purchase Order. Notwithstanding anything to the contrary contained herein, or in the Purchase order, NMRC may reject a Bid, withdraw the Purchase order, or terminate the Contract, as the case may be, without being liable in any manner whatsoever to the Bidder or Agency, as the case may be, if it determines that the Bidder or Agency, as the case may be, has, directly or indirectly or through an agent, engaged in corrupt practice, fraudulent practice, coercive practice, undesirable practice or restrictive practice in the Bidding Process. In such an event, NMRC shall be entitled to forfeit & appropriate Bid Security or Security Deposit (interest free)/ Performance Bank Guarantee, as the case may be, as Damages, without prejudice to any other right or remedy available to NMRC under Bidding Documents and/ or Contract Agreement, or otherwise.
- b. Without prejudice to the rights of NMRC under Clause 5.9a herein above and the rights and remedies which NMRC may have under the Purchase order, or otherwise if a Bidder or Agency, as the case may be, is found by NMRC to have directly or indirectly or through an agent, engaged or indulged in any corrupt practice, fraudulent practice, coercive practice, undesirable practice or restrictive practice during the Bidding Process, or after the issue of the Purchase order, such Bidder or Agency shall not be eligible to participate in any tender or RFP issued by NMRC during a period of 3 (three) years from the date such Bidder is found by NMRC to have engaged, directly or indirectly, in any corrupt practice, fraudulent practice, coercive practice, undesirable practice or restrictive practice.

- c. For the purposes of this Clause, the following terms shall have the meaning herein after respectively assigned to them:
 - i. “corrupt practice” means the offering, receiving, or soliciting, directly or indirectly, of anything of value to influence the action of a public official in the selection process or in contract execution;
 - ii. “fraudulent practice” means a misrepresentation or omission of facts in order to influence a selection process or the execution of a contract;
 - iii. “collusive practices” means a scheme or arrangement between the Agency, with or without the knowledge of the authority, designed to establish prices at artificial, non-competitive levels;
 - iv. “coercive practices” means harming or threatening to harm, directly or indirectly, persons or their property to influence their participation in a procurement process, or affect the execution of a contract

- d. Measures to be taken:
 - i. The Corporation shall have right to cancel the engagement of the Agency, if found to be indulged in corrupt, fraudulent, collusive or coercive practices either during the selection process or during the execution of the contract.

5.10 Settlement of Disputes

a) Amicable Settlement

The Parties agree that the avoidance or early resolution of disputes is crucial for a smooth execution of the Contract and the success of the Project. The Parties shall use their best efforts to settle amicably all disputes arising out of or in connection with this Contract/Agreement or its interpretation.

b) Conciliation

In the event of any dispute, differences arising out of this agreement or breach, termination, firstly be attempted to settle dispute by sole conciliator appointed/nominated by Executive Director, NMRC. The conciliator shall be appointed within a period of 30 days from date of receipt of written notice/ demand of appointment of conciliator from either party. The provisions of the Arbitration and Conciliation Act 1996 shall apply.

c) Arbitration

In the event of any dispute and/ or difference whatsoever arising under this contract or in connection therewith, including any question relating to the meaning, scope and interpretation of this Contract or it's clause or any alleged breach thereof, the same shall be attempted to be settled by mutual discussions and consultations between the parties hereof. In the event of any such dispute, any/ or difference is not settled in aforesaid manner, then the dispute(s) shall be referred for arbitration. The sole Arbitrator would be appointed by the MD, NMRC. The decision of the said sole Arbitrator shall be final subject to the above, the provisions of the Arbitration and Conciliation Act, 1996 shall apply. The arbitration proceedings shall take place in Noida.

d) Jurisdiction

With respect to any dispute arising out of or related to this Contract, the parties consent to the exclusive jurisdiction of, and venue in, the District Court located in Gautam Budh Nagar, Uttar Pradesh, India.

e) Cost

The cost of arbitration shall be borne by the respective parties. The cost shall, inter alia, include the fees of the Arbitrator(s) as per rates fixed by the Employer from time to time.

6 Section 6: Forms

Form 1: Letter of Proposal Submission

[Location, Date]

To

Dy.COS
Noida Metro Rail Corporation (NMRC) Limited
Block-III, 3rd Floor, Ganga Shopping Complex, Sector-29,
Noida -201301
District Gautam Budh Nagar, Uttar Pradesh

Subject: Supply of Span Dropper Assembly for Traction Department

Dear Sir,

We, the undersigned, offer to Supply of Span Dropper Assembly for Traction Department in accordance with your RFP Document dated [Insert Date] and our Proposal. We are hereby submitting our Technical and Financial Proposal. We confirm that we have read the RFP Document in totality and abide by the terms and conditions stated in the document.

We acknowledge that we have

- Studied and analyzed and satisfied ourselves about all the requirement of the tender including but not limited to market and market conditions
- Carefully assessed the commerciality of Project and that we will be fully responsible for all its assessment in this regard.

We confirm and declare that no agent, middleman or any intermediary has been, or will be, engaged to provide any services, or any other item or work related to the award and performance of this Contract and declare that no agency commission or any payment which may be construed as an agency commission has been, or will be, paid and that the tender price will not include any such amount.

We have filled the complete information correctly in **Form 10**: Bid Details

Authorized signatory

Name:

Date:

Name of the Bidder with seal

Form 2: Firm Details

1.	<p>Title and name of the Project: Supply of Span Dropper Assembly for Traction Department</p>
2.	<p>State the structure of the Bidder's organization (Bidders to complete/delete as appropriate) Sole Bidder</p>
3.	<p>For Bidders who are individual companies or firms, state the following:</p> <p>Name of Company or firm:</p> <p>Legal status: (e.g. incorporated private company, proprietorship, etc.)</p> <p>Registered address:</p> <p>Year of incorporation.....</p> <p>Principal place of business:</p> <p>Contact person:</p> <p>Contact person's title:</p> <p>Address, telephone, facsimile number and e-mail ID of contact person:</p>

Form 3: Work Experience

The following format shall be used for statement of experience of Bidder:

S.No.	Similar Contract description	Contract Identification Number	Award date & Completion date	Employer's Name, address, telephone number, e-mail etc	Role in contract		If in JV/consortium then % participation	Completion cost	Value of similar work in completed work
					Individual	JV/ Consortium			
1									
2									
3									
4									
Add required number of rows									

Authorized signatory

Name:

Date:

Name of the Bidder with seal

NOTE:

1. Only the value of contract as executed by the applicant/member in his own name should be indicated. Where a work is undertaken by a group, only that portion of the contract which is undertaken by the concerned applicant/member should be indicated and the remaining done by the other members of the group be excluded. This is to be substantiated with documentary evidence (Experience Certificate/Work Completion Certificate on Client's Letter Head will only be considered) which clearly mentioned the amount for the "Supply of Span Dropper Assembly for Traction Department".
2. The bidder shall upload details of work executed by them in the prescribed format for the works to be considered for qualification of work experience criteria. Documentary proof such as completion certificates from the client clearly indicating the nature/scope of work, actual completion cost and actual date of completion for such work should be uploaded. In case work is executed for private client documentary proof such as copy of work order, Bill of quantities, Bill wise details of payment received certified by CA, TDS certificates for all the payments received, copy of final/ last bill paid by the client should be uploaded. The offers submitted without this documentary proof will not be evaluated.
3. Value of successfully completed portion of any ongoing work up to the last day of the previous month of tender submission will also be considered for qualification of work experience criteria.
4. For completed works, value of work done shall be updated to the last day of the previous month of tender submission price level assuming 5% inflation for Indian Rupees every year and 2% for foreign currency portions per year. The exchange rate of foreign currency shall be applicable 28 days before the submission date of tender.
5. If the qualifying work(s) were done by them in JV/Consortium having different constituents, then the value of work as per their percentage participation in such JV/Consortium shall be considered. This is to be substantiated with documentary evidence.
6. If the above work(s) comprise(s) other works also, then client's certificate clearly indicating the amount of work done in respect of the "similar work" shall be furnished by the bidder in support of work experience along-with their tender submissions.

Form 4: Financial Capability Details

This is to certify that the Average Annual Turnover and Profitability of M/s _____ having registered office at _____, as applicable, is as below:

S.No.	Financial year	Name of the Bidder	Turnover from Similar Work
1.	FY 2023-24		
2.	FY 2022-23		
3.	FY 2021-22		
	Average Annual Turnover		

S.No.	Financial Year	Name of Bidder	Profitability
1.	FY 2023-24		
2.	FY 2022-23		
3.	FY 2021-22		

Certificate of the Chartered Accountants/Statutory Auditors

Based on Audited Accounts and other relevant documents of _____ (Name of Bidder), we M/s _____, Chartered Accountants/ Statutory Auditors, certify that the above information pertaining to FY 2021-22, 2022-23 and 2023-24 is correct.

Signature and Seal of Chartered Accountants/Statutory Auditors (with membership no.)

UDIN-

Date-

Firm Regd. No.-

Undertaking

I/ We _____ (M/s _____) declare that the Annual Accounts for FY 2023-24 have not been audited so far. We are submitting the CA certified provisional accounts, which shall be substantiated by the Audited Accounts, when prepared.

Authorised Signatory

(Name & Designation of Authorised Signatory)

In case the Financial Statements for the latest financial year are not audited and therefore the Bidder cannot make it available, the Bidder shall give an undertaking to this effect and the statutory auditor/charted accountant shall certify the same. In such a case, the Bidder shall provide the Audited Financial Statements for 2 (two) years preceding the year for which the Audited Financial Statement is not being provided. Also, pertaining to latest financial year, the bidder shall submit an affidavit certifying that "The Annual Accounts have not been audited so far. We are submitting the CA certified provisional accounts, which shall be substantiated by the Audited Accounts, when prepared."

NOTE:

1. All such documents reflect the financial data of the bidder and not that of sister or parent company.
2. The financial data in above prescribed format shall be certified by CA/ Company Auditor under his signature and stamp in original along with membership no. and UDIN.
3. The Bidder shall provide the audited annual financial statements as required.

Form 5: Memorandum

Name of Work: Supply of Span Dropper Assembly for Traction Department

I/We agree to keep the quoted rate open for acceptance for 180 days from the due date of submission thereof and not make any modification in its terms and conditions.

I hereby declare that I shall treat the quotation documents, drawings and other records connected with the works as secret/ confidential documents and shall not communicate information derived there from to any person other than the information in any manner prejudicial to the safety of NMRC.

Signature of the bidder with seal
Dated:

Witness:

Address:

Occupation

Form6: Undertaking

Name of Work: Supply of Span Dropper Assembly for Traction Department

I confirm that We (Bidder), _____

- a. Have not been banned /declared ineligible for corrupt and fraudulent practices by any government/government-undertaking/ semi-government/ govt. controlled institutions, any court of law having jurisdiction in India for the past 5 (five) years.
- b. Do not have any pending litigation & non-performing contracts during last 5 (five) years. Further, has not been barred by any government/government-undertaking/ semi-government/ govt. controlled institutions
- c. Have not abandoned any work in last 5 (five) years.
- d. Have not delayed in similar work completion during orders executed in last 5 (five) years.
- e. Do not ever been terminated due to poor performance.
- f. Have not suffered Bankruptcy/ insolvency in last 5 (five) years.
- g. Have not been blacklisted/debarred by any organization.
- h. Neither penalized with liquidated damages of 10% (or more) of the contract value due to delay nor imposed with penalty of 10% (or more) of the contract value due to any other reason in any contract regarding supply of similar items of value more than 10% of NIT cost of work, during 5 (five) years.
- i. Have not been put on defaulter's list of EPF/ESI/GST/Labour Deptt. etc during the last 5 (five) years.
- j. Have not been be involved in any illegal activity and/or has not been charge sheeted for any criminal act during the last 5 (five) years.
- k. Have not submitted any misleading information in the Bid.
- l. Are financially sound to perform the work.

Authorized signatory

Name:

Date:

Name of the Bidder with seal

Form 7: Saleable Form for Tender Document

Bid No.

The required fee of tender form has been deposited in _____ Bank A/c No. _____ RTGS/NEFT and the scanned copy of UTR receipt with Transaction Id is being enclosed with E-tender documents. If the copy of UTR receipt is not uploaded with the E-tender the tender shall be rejected.

DETAILS OF EARNEST MONEY ATTACHED

The required amount of Earnest money has been deposited in _____ Bank A/c No. _____ RTGS/NEFT and the scanned copy of UTR receipt with transaction Id is being enclosed with E-tender documents. If the copy of UTR receipt is not uploaded with the E-tender the tender shall be rejected.

BIDDER

Form 8: Declaration of Refund of Earnest Money

**Noida Metro Rail Corporation (NMRC) Limited
Block-III, 3rd Floor,
Ganga Shopping Complex, Sector-29, Noida -201301,
District Gautam Budh Nagar, Uttar Pradesh, India**

1	Bidder Name	
2	Bidder Address	
3	Bank Name	
4	Bank Branch	
5	A/c No	
6	IFSC	
7	PAN	
8	Tin/TAN	
9	GST No.	
10	Phone No.	
11	Mobile No.	
12	Email-Id	
13	Type of Account	
FOR OFFICE USE ONLY		
14	Party Unique Id	

The above provided information is true to the best of my knowledge.

Date:

Signature with Stamp/Seal

Form 9: Bid Offer/ BOQ (Format)

To

Dy.COS
Noida Metro Rail Corporation (NMRC) Limited
Block-III, 3rd Floor, Ganga Shopping Complex, Sector-29,
Noida -201301
District Gautam Budh Nagar, Uttar Pradesh

THIS FORM IS NOT TO BE FILLED. THE BIDDERS ARE REQUIRED TO FILL THE FINANCIAL PROPOSAL IN XLS FORMAT AFTER DOWNLOADING THE FORM FROM THE E-PROCUREMENT WEBSITE FOR THIS TENDER DOCUMENT

Sub: Supply of Span Dropper Assembly for Traction Department

Dear Sir,

I/we have read and examined the RFP document, general terms and conditions for the work.

I/we hereby quote the following Total price for services in rupees for providing **Supply of Span Dropper Assembly for Traction Department**, payable by NMRC.

Price Schedule for Supply of Span Dropper Assembly for Traction Department

NUMBER #	TEXT #	NUMBER #	TEXT #	NUMBER #	NUMBER #	NUMBER #	TEXT #
Sl. No.	Item Description	Quantity	Units	Price (Exclusive GST) Per unit In Figures To be entered by the Bidder Rs. P	Total Amount (Exclusive GST) by Bidder for required Quantity (In Figures) Rs. P	GST (%)	TOTAL AMOUNT (Inclusive GST) by Bidder for required Quantity (In Figures) Rs. P
1	2	3	4	5	6	7	8
1	Span dropper Assembly(which includes (i) Dropper catenary wire clip-1 Nos (ii) Dropper contact wire clip- 1 Nos (iii) Cable Lug - 2 Nos (iv) compresion connector - 2 Nos (v) Thimble - 2 Nos (vi) Clip - 1 Nos (vii) Dropper Wire BZII, 10mm ² , 7X7X.51 - App. 1.66 Mtr (viii) Hexagon Nut and Bolt with Check nut 10M, SS A2 70- 2 Bolt, 2 Nut, 1 Check Nut as per specification & drawing attached in tender	2200	Nos.				
Total Quoted Amount(In Rupees) inclusive GST(in Figures)							
Total Quoted Amount(In Rupees) inclusive GST(in Words)							

*The bidder is required to fill only grey cells.

Note:

1. **The bidder shall mention Quoted Rate (Per item) In Figures.**
2. The Amount Arrived at from Quoted Rate, Per item along with Miscellaneous Charges in the Commercial Bid, would be treated as complete in all respect. It will be deemed to include all incidental charges, supervision, transport, contractor's profit and establishment/overheads, all risks & insurance liabilities, compliance of labour laws and other obligations set out or implied in the contract.
3. **The total payment due to contractor shall be inclusive of all taxes, Tender Requirements, Statutory Contributions, etc.**
4. The GST will be reimbursed based on the invoice of GST paid to the concerned authority by the contractor.
5. The rates and prices tendered in the priced bill of quantities are for complete work and complete in all respects. It will be deemed to include all plant, labour, supervision, materials, including all leads, lifts, ascents, descants, crossing of Rly. tracks and any other obstructions etc. unloading, loading, handling, re-handling, taxes (including GST), royalty and compensation etc. all temporary works, erection, maintenance, contractor's profit and establishment/ over heads, together with all general risks, insurance liabilities and obligations set out or implied in the contract.
6. We have completely read and understood the Bid Document. The Financial Tender submitted is unconditional and fulfils all the requirements of the Tender Document.
7. Our Financial Proposal shall be binding upon us subject to the modifications resulting from contract negotiations, up to expiration of the validity period of the Proposal. We understand you are not bound to accept any Proposal you receive.

Signature and Name of the Authorized Person

NAME OF THE BIDDER AND SEAL

Form 10: Bid Details

The following list is intended to help the bidders in submitting offer which are complete. An incomplete offer is liable to be rejected. Bidders are advised to go through the list carefully and take necessary action.

S.No.	Particulars	Attached Yes / No / Not Applicable	Page no. (Mandatory)
1	Bid Processing Fees		
2	Earnest Money Deposit		
3	Form 1: Letter of Proposal Submission		
4	Form 2: Firm Details		
5	Form 3: Work Experience		
6	Form 4: Financial Capability Details		
7	Form 5: Memorandum		
8	Form 6: Undertaking		
9	Form 7: Saleable form for Tender Document		
10	Form 8: Declaration of refund of Earnest Money		
11	Form 9: Bid offer/BOQ format		
12	Form 10: Bid Details		
13	Registration certificate of the firm/ Partnership deed/ certificate of incorporation, etc.		
14	Form 4: Financial Capability Details A copy of the Audited balance sheets and Profit and Loss Statements for the last 3 (three) financial years i.e. for FY 2021-22, 2022-23, 2023-24.		
15	Self attested copy of PAN, ITR for FY 2021-22, 2022-23, 2023-24.		
16	Any other document asked by the Purchaser if submitted, specify the documents Or Any other document which the Bidder considers relevant		
17	The offered material is in compliance with attached drawing and specification		
18	The relevant type test reports as mentioned in Annexure A & relevant IEC/EN standards are submitted.		

ANNEXURE – A**Particular Specification****1- Wire Specification**

1	Test object	Wire Bz10 mm2 7*7*0.51
A	Material	Bronze
B	Test Specification	DIN 43138:1980-09, DIN48203-02:1984-3
1.1	Test	
A	Material Composition	BzII
B	Surface check of rope/single wire	Visual check according to DIN48203-2, clause2.3
C	Dimension,Weight, Marking of rope	Measurement according to standards: DIN 43138,Clause 3 Diameter 4.65mm ± 0.15mm Weight 90.3Kg/Km ± 8% Manufacturer's identification thread should be present
D	Specification of single wire	Diameter 0.51mm ± 0.01mm
E	Tensile strength of rope/single wire	Measurement according to standardsDIN43138, Clause 3,DIN48203-2, Clause-2.5 Breaking Load of rope : 5.6 kN , Single wire tensile strength :589N/mm2-730N/mm2
F	Conductivity and resistivity of rope	Measurement according to standardsDIN43138, Clause 4,DIN48203, Clause-2.6 Resistivity (at 20 degree Celsius in ohm-mm2/m) 0.0246-0.0278 Conductivity in m/ohm*mm2: 36.0-40.6
G	Direction of lay and lay ratio of rope	Check according to standards DIN43138, Clause 2,DIN48203, Clause-3 Rope lay of direction of complete rope (49 strand) should be Z, Lay ratio of rope 38.0mm-46.0mm Rope lay of direction of single rope (07 strand) should be S, Lay ratio of rope 12.0mm-16.0mm

2- Dropper assembly test

A	Mechanical fatigue test	The compression distance should be between 20 mm and 200 mm and the force in the dropper should lie between 100 N to 400 N. The frequency of the cycles shall be between 0.5 Hz and 10 Hz, and a minimum of 20,00,000 cycles shall be performed. The dropper shall not break before the specified number of cycles is exceeded. As per the Standard: EN 50119:2009+A1:2013, clause 8.7
B	Mechanical test	The Contact and catenary clip shall not be pulled off until a force of at least 3 kN is reached. As per the Standard: EN 50119:2009+A1:2013, clause 8.7

3 -Type Test

The material shall conform to routine / type test as per respective standard i.e. DIN 43138:1980-09, DIN48203-02:1984-3and Dropper assembly type test as per EN 50119

4- Standards

No	Title	Content
A	EN 50110-1	Operation of electrical installation
B	DIN 48201-1	Copper stranded conductors
C	DIN 48201-2	Bronze stranded conductors
D	DIN 48201-3	Steel stranded conductors
E	EN 50149	Grooved contact wires
F	EN 50119	Railway applications- Fixed installations- Electrical traction overhead contact lines

The successful bidder shall submit the GTP AND FAT PLAN OF SPAN DROPPER ASSEMBLY/WIRE FOR APPROVAL OF ENGINEER IN CHARGE .The material shall be accepted after satisfactory FAT report.

5- Span dropper parts details and drawings

Item name	Qty.	Parts Description of dropper assembly	SAP- Material no	Parts quantity per assembly	Total required quantity
Dropper assembly	2200 Sets	Dropper clip 70 ,For 65mm ² Catenary Wire	8WL4624-3	1 Nos	2200 Nos
		Dropper clip 50, For 107 mm ² Contact Wire	8WL4620-0A	1 Nos	2200 Nos
		Cable Lug ,Dropper wire BZ 10 mm ² , DIN 46235, Cu-ETP, or equivalent	8WL1575-0	2 Nos	4400 Nos
		Compression connector ,10 f 20, Cu-ETP, or equivalent	8WL1520-0	2 Nos	4400 Nos
		Thimble 10f	8WL1500-2	2 Nos	4400 Nos
		Clip M4 for wire 50/70mm ² ,Bronze grade II, or equivalent	8WL4622-0	1 Nos	2200 Nos
		Dropper wire BZ II, 10 mm ² , 7X7X.51, DIN 43138:1980-09, or equivalent	8WL7060-2	App. 1.66 Mtr	3652 mtrs
		Hexagonal nut & bolt with checknut 10 M, SS A2-70		2 Nos Nut ,2 Nos Bolt & 1 No checknut	4400 Nos Nut ,4400 Nos Bolt & 2200 No checknut

Thimble

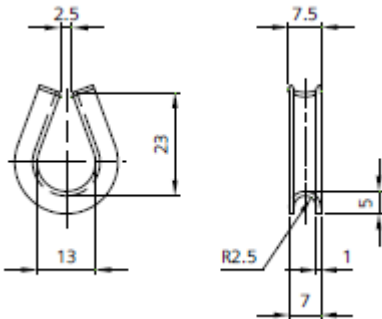

Order no. 8WL1500-2(Thimble 10f)	
Designation	Thimble 10f
Material	stlSt
for wires	10 mm ²
Weight	0.30 kg/100 pcs.

Compression connector



Designation Crimped/compression connector 10f-20	
Material	Cu-ETP
for wires	10f mm ² 16 mm ²
Weight	0.40 kg/100 pcs.
dia (d)	5 mm
thickness (s)	0.75 mm
L	20 mm

Dropper clip

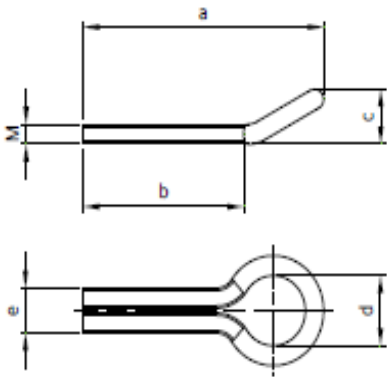

Order no. 8WL4622-0 Designation Clip M4 (DIN 48201)	
Material	BzII
for wires	50/70 mm ²
Weight	1.00 kg/100 pcs.
a	52.5 mm
b	35 mm
c	11 mm
d	14 mm
e	9 mm
M	M4

Cable lug

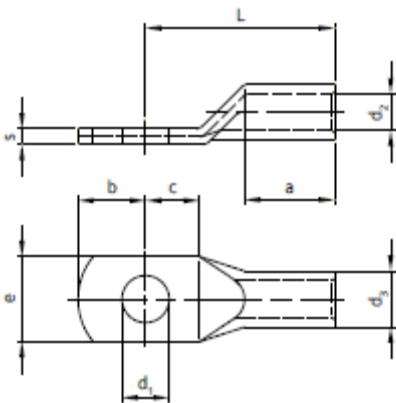

Designation	Cable lug 10-16
Material	Cu-ETP
for wires	10f, 16 mm ²
Weight	1.3 kg/100 pcs.
a	20 mm
b	15 mm
c	12 mm
s	2.5 mm
L	36 mm
d1	10.5 mm
d2	5.5 mm
d3	8.5 mm
e	17 mm

Catenary wire clip

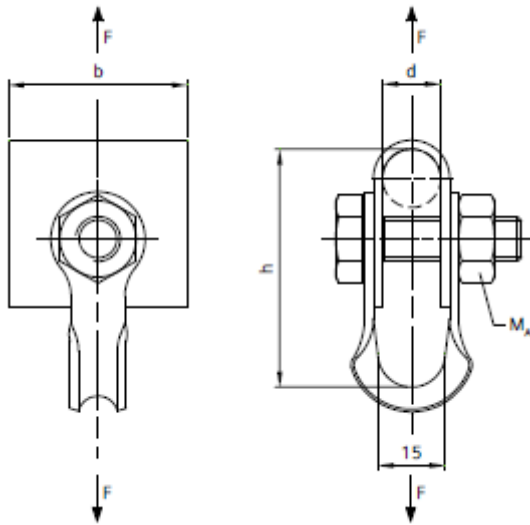

Designation	Dropper clip 70
Clamp hoop	CuNiSi/ StlST
Dropper Strap	CuNiSi/ StlST
Bolt M10	StlST
Nut	StlST
For wires	70 mm ²
Weight	.12 Kg
Permanent operating load	2kN
Min. failing load	6kN
Tightening Torque	25Nm
b	30mm
d	10.6mm
h	51mm

Contact wire clip

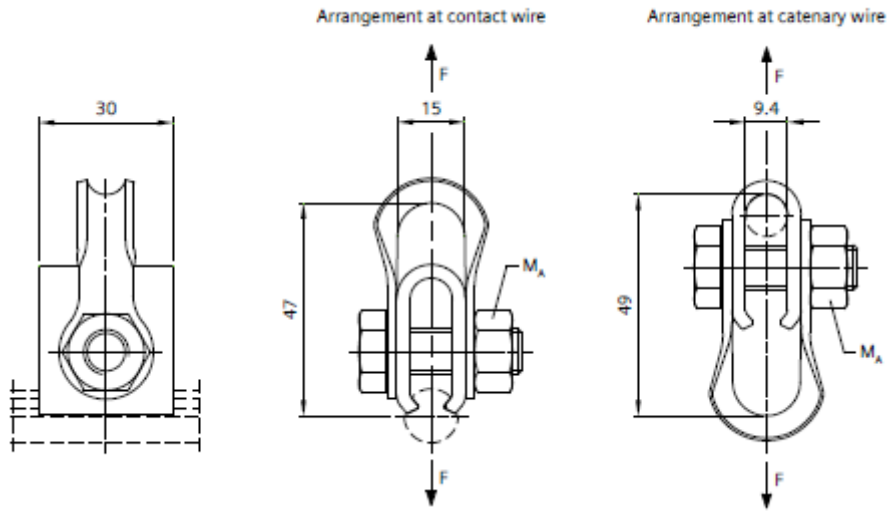

Designation	Dropper clip 50
Clamp hoop	CuNiSi/ St1ST
Dropper Strap	CuNiSi/ St1ST
Bolt M10	St1ST
Nut	St1ST
Weight	.11 Kg
Permanent operating load	2kN
Min. failing load	6kN
Tightening Torque	25Nm
For contact wire	107 sq. mm

Contact wire

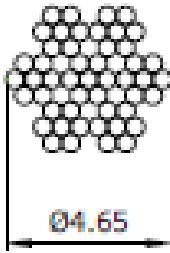

Wire 10, flexible made of Bronze (DIN 43138:1980-09)	
Dropper wire	Bronze, 10 mm ² , 7X7X.51
Material	Bronze
Weight	0.09 kg/m
Nominal cross-section	10 mm ²
Number of wires	49
Min. tensile strength	589 N/mm ²
Permissible Permanent current	102 A
Electric conductivity	36 Sm/mm ²
Specific resistance	0.0277 Ωmm ² /m
Valid at 80 °C limit temperature	
Note : 7X7X.51 will be interpreted as 7(1st no. may be considered for the total no. of bunch of strands), 7(2nd no. may be considered as no. of strand , .51 (3rd no. may be considered as diameter of each strand)	